



บริษัท เอดีดี เฟอร์เนส จำกัด

ADD FURNACE CO.,LTD.

44 ซอยบรมราชชนนี 70 ถนนบรมราชชนนี แขวงศาลาธรรมสพน์ เขตทวีวัฒนา กรุงเทพฯ 10170

โทร: 02-888-3472 โทร: ออกแบบ:08-08-170-170 แฟกซ์: 02-888-3258

<https://www.add-furnace.com> E-mail: sales@add-furnace.com

Honeywell | Industrial & Commercial Thermal

**krom
schroder**

Linear flow controls VFC

Linear flow controls with actuator IFC

Technical Information · GB

3 Edition 01.161

- Linear relationship between adjustment angle and flow rate
- Large control ratio of 25:1
- Actuators IC 20 or IC 40 mounted directly
- Actuator IC 30 (24 V DC) can be mounted
- For gas and air
- Low leakage rates
- High control accuracy
- EU certified



ERC CE



บริษัท เอดีดี เฟอร์เนส จำกัด

ADD FURNACE CO.,LTD.

44 ซอยบรมราชชนนี 70 ถนนบรมราชชนนี แขวงศาลาธรรมสพน์ เขตทวีวัฒนา กรุงเทพฯ 10170

โทร: 02-888-3472 โทร: ออกแบบ:08-08-170-170 แฟกซ์: 02-888-3258

<https://www.add-furnace.com> E-mail: sales@add-furnace.com

Contents

Linear flow controls VFC	1
Linear flow controls with actuator IFC	1
Contents	2
1 Application	3
1.1 Examples of application	4
1.1.1 Lambda control.....	4
1.1.2 Adjusting the burner capacity.....	4
1.1.3 Zone control	5
1.1.4 Excess air burner	6
2 Certification	7
3 Function of the linear flow control VFC	8
4 Replacement possibilities	9
4.1.1 Search for order number or type	9
5 Flow rate	10
5.1 kv value	11
6 Selection	12
6.1 Selection table.....	12
6.1.1 IFC	12
6.1.2 VFC	13
6.2 IFC, VFC type code	14
6.3 Control characteristics	15
7 Project planning information	16
7.1 Installation	16
7.1.1 IC 20, IC 40 with VFC	16
7.1.2 IC 30 with VFC	16
8 Accessories	17
8.1 Pressure switches for gas.....	17
8.1.1 DG..VC for IFC	17
8.1.2 Attachment to IFC.....	17
8.2 Pressure test points	17
8.3 Seal set VA	18
8.4 Fastening set IC 20, IC 40	18
8.5 Adapter set IC 30	18
9 Technical data	19

9.1 VFC.....	19
9.2 IC 20, IC 20..E.....	19
9.2.1 IC 20.....	20
9.2.2 IC 20..E	20
9.3 IC 30	20
9.4 IC 40	20
9.4.1 Running times and torques	21
9.5 Dimensions of IFC [mm]	22
9.6 Dimensions of VFC with IC 30 [mm].....	23
9.7 Dimensions of IFC [inch].....	24
9.8 Dimensions of VFC with IC 30 [inch]	25



บริษัท เอดีดี เฟอร์เนส จำกัด

ADD FURNACE CO.,LTD.

44 ซอยบรมราชชนนี 70 ถนนบรมราชชนนี แขวงศาลาธรรมสพน์ เขตทวีวัฒนา กรุงเทพฯ 10170

โทร: 02-888-3472 โทร: ออกแบบ:08-08-170-170 แฟกซ์: 02-888-3258

https://www.add-furnace.com E-mail: sales@add-furnace.com

Application



The IFC is composed of linear flow control VFC and actuator IC 20 or IC 40.

It is designed to adjust volumes of gas and cold air on various appliances. The IFC is designed for control ratios up to 25:1 and is suitable for regulating flow rates for modulating or stage-controlled combustion processes.

Actuator IC 20 is controlled by a modulating signal or three-point step signal. Actuator IC 40 offers additional functions. It can be adjusted using the BCSof software via an optical interface. The control type (two-point signal, three-point step signal or continuous control), running times, angles of rotation and intermediate positions can thus be programmed.

Actuator IC 30 (24 V DC) can also be combined with a VFC.

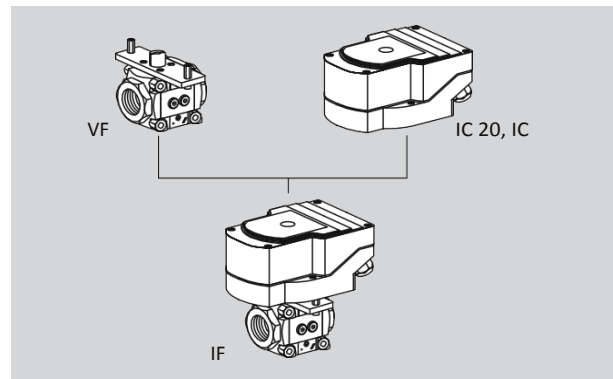



บริษัท เอดีดี เฟอร์เนส จำกัด

ADD FURNACE CO.,LTD.

44 ซอยบรมราชชนนี 70 ถนนบรมราชชนนี แขวงศาลาธรรมสพน์ เขตทวีวัฒนา กรุงเทพฯ 10170

โทร: 02-888-3472 โทร: ออกแบบ:08-08-170-170 แฟกซ์: 02-888-3258

<https://www.add-furnace.com> E-mail: sales@add-furnace.com

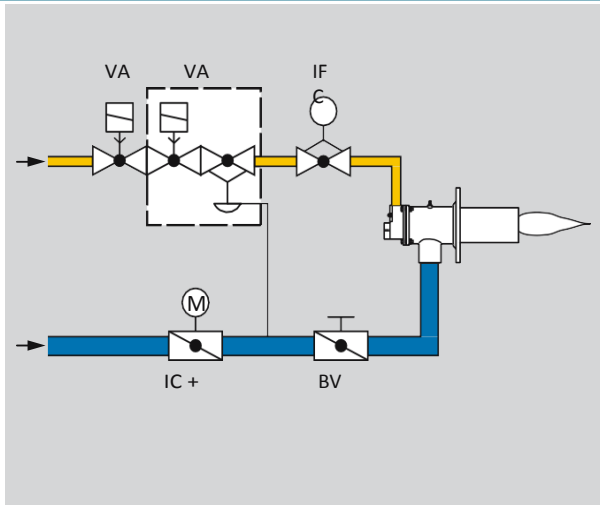

1.1 Examples of application

1.1.1 Lambda control

If the burner is to be operated with different lambda values for process reasons, the IFC can be used to correct the lambda value.

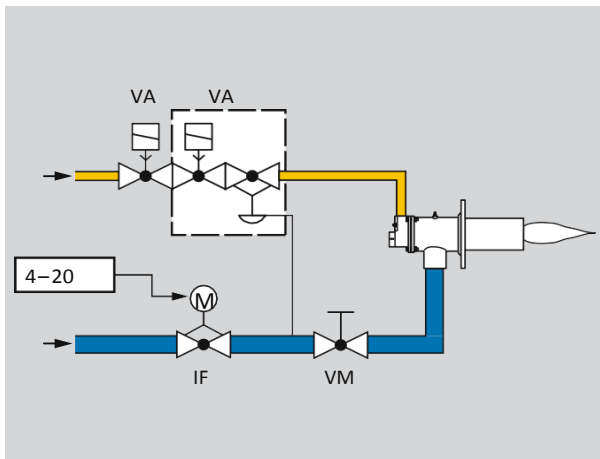

1.1.2 Adjusting the burner capacity

In pneumatic ratio control systems, the IFC with actuator IC 20..E determines the air volume for the required burner capacity.

The fine-adjusting valve VMV is used to adjust the high- fire rate.



บริษัท เอดีดี เฟอร์เนส จำกัด

ADD FURNACE CO.,LTD.

44 ซอยบรมราชชนนี 70 ถนนบรมราชชนนี แขวงศาลาธรรมสพน์ เขตทวีวัฒนา กรุงเทพฯ 10170

โทร: 02-888-3472 โทร: ออกแบบ:08-08-170-170 แฟกซ์: 02-888-3258

https://www.add-furnace.com E-mail: sales@add-furnace.com

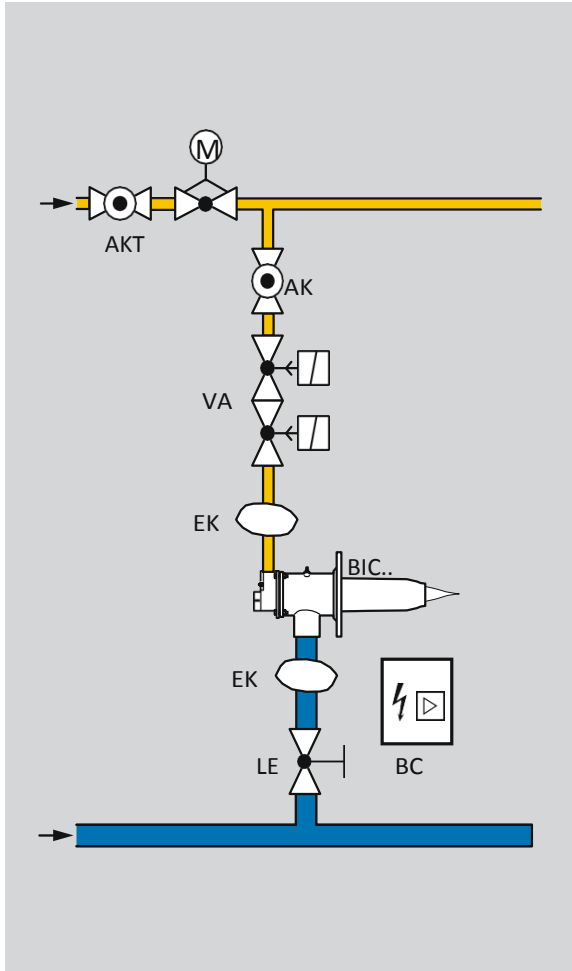

1.1.3 Zone control

After being released by the burner control unit, the gas solenoid valves open and the IFC is set to ignition position. The burner is ignited by the burner control unit BCU. The gas flow rate can be adjusted continuously using the IFC. The air flow rate remains constant.



บริษัท เอดีดี เฟอร์เนส จำกัด

ADD FURNACE CO.,LTD.

44 ซอยบรมราชชนนี 70 ถนนบรมราชชนนี แขวงศาลาธรรมสพน์ เขตทวีวัฒนา กรุงเทพฯ 10170

โทร: 02-888-3472 โทร: ออกแบบ:08-08-170-170 แฟกซ์: 02-888-3258

<https://www.add-furnace.com> E-mail: sales@add-furnace.com

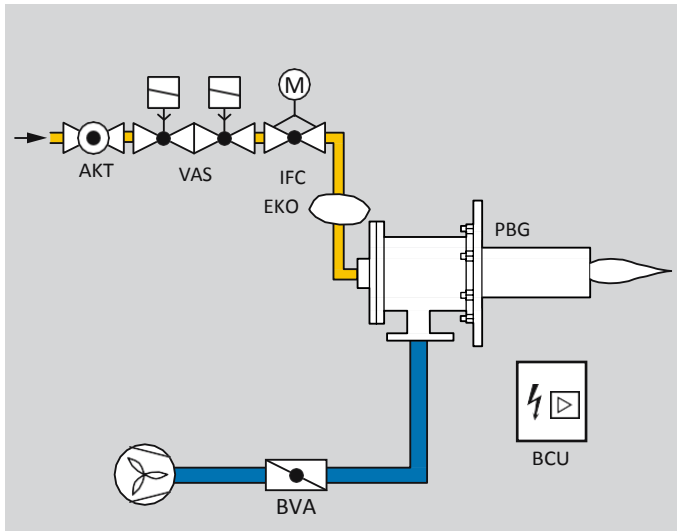

1.1.4 Excess air burner

After being released by the burner control unit, the IFC moves to ignition position. The burner is ignited by the burner control unit BCU. The gas flow rate can be adjusted continuously using the IFC. The air flow rate remains constant.



บริษัท เอดีดี เฟอร์เนส จำกัด

ADD FURNACE CO.,LTD.

44 ซอยบรมราชชนนี 70 ถนนบรมราชชนนี แขวงศาลาธรรมสพน์ เขตทวีวัฒนา กรุงเทพฯ 10170

โทร: 02-888-3472 โทร: ออกแบบ:08-08-170-170 แฟกซ์: 02-888-3258

<https://www.add-furnace.com> E-mail: sales@add-furnace.com

2 Certification

Certificates VFC, see Docuthek.

Certificates IC, see Docuthek.

EU certified



VFC

pursuant to

- Gas Appliances Directive (2009/142/EC) in conjunction with EN 13611

IC 20, IC 40

Meets the requirements of the

- Low Voltage Directive (2006/95/EC) on the basis of EN 60730-1
- Electromagnetic Compatibility Directive (2004/108/EC) on the basis of EN 50082-2 and EN 50081-1

Eurasian Customs Union



The product VFC/IC 20/IC 40 meets the technical specifications of the Eurasian Customs Union.



บริษัท เอดีดี เฟอร์เนส จำกัด

ADD FURNACE CO.,LTD.

44 ซอยบรมราชชนนี 70 ถนนบรมราชชนนี แขวงศาลาธรรมสพน์ เขตทวีวัฒนา กรุงเทพฯ 10170

โทร: 02-888-3472 โทร: ออกแบบ:08-08-170-170 แฟกซ์: 02-888-3258

<https://www.add-furnace.com> E-mail: sales@add-furnace.com

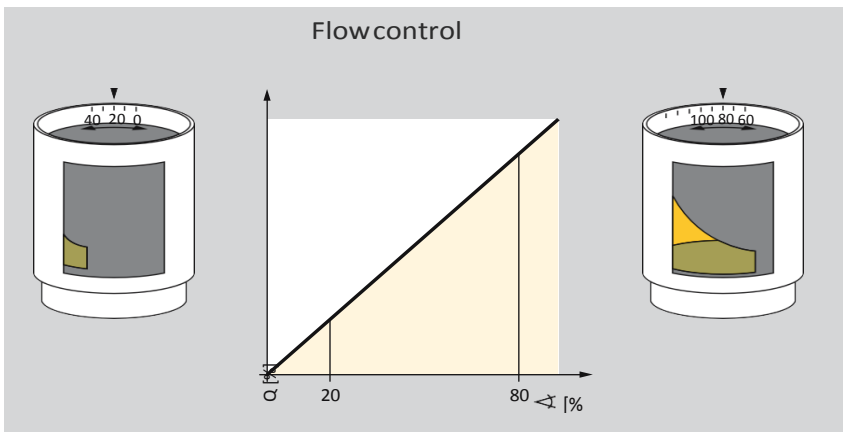
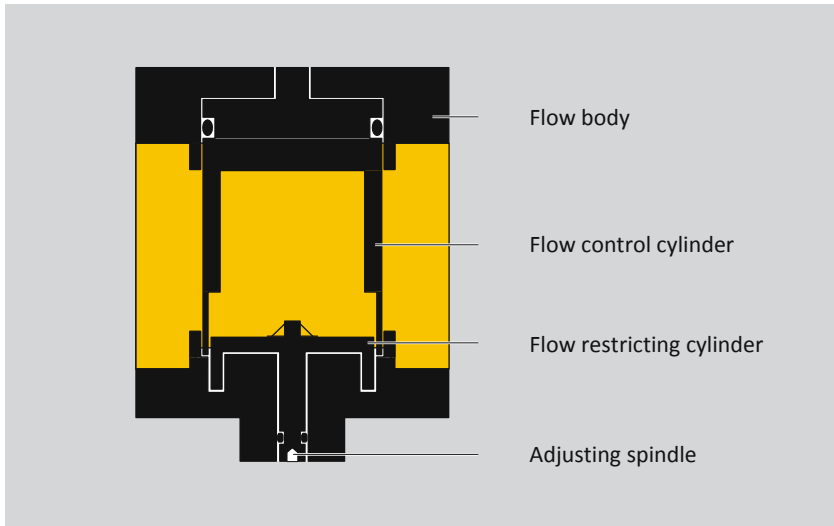

Function of the linear

The linear flow control VFC uses the rotary valve principle. A flow control cylinder with an opening specially designed for linear flow is installed in the flow body. This flow control cylinder sets the desired flow rate by being turned. The maximum flow can be limited in broad ranges by means of a flow restricting cylinder. This allows optimum adaptation to the capacity required, without limiting control quality. Adjustment is carried out using an adjusting spindle.



บริษัท เอดีดี เฟอร์เนส จำกัด

ADD FURNACE CO.,LTD.

44 ซอยบรมราชชนนี 70 ถนนบรมราชชนนี แขวงศาลาธรรมสพน์ เขตทวีวัฒนา กรุงเทพฯ 10170

โทร: 02-888-3472 โทร: ออกแบบ:08-08-170-170 แฟกซ์: 02-888-3258

https://www.add-furnace.com E-mail: sales@add-furnace.com

4 Replacement possibilities

Linear flow control LFC is to be replaced by VFC or IFC

LFC		VFC	
Type designation	Order No.	Type designation	Order No.
LFC 108/10R05	25810250	VFC 110/10R05-08PPPP	88300201
LFC 108/15R05	25810240	VFC 115/15R05-08PPPP	88300202
LFC 108/20R05	25810230	VFC 120/20R05-08PPPP	88300203
LFC 108/25R05	25810220	VFC 125/25R05-08PPPP	88300204
LFC 115/10R05	25810200	VFC 110/10R05-15PPPP	88300206
LFC 115/15R05	25810190	VFC 115/15R05-15PPPP	88300207
LFC 115/20R05	25810180	VFC 120/20R05-15PPPP	88300208
LFC 115/25R05	25810170	VFC 125/25R05-15PPPP	88300209
LFC 120/10R05	25810150	VFC 110/10R05-20PPPP	88300211
LFC 120/15R05	25810140	VFC 115/15R05-20PPPP	88300212
LFC 120/20R05	25810130	VFC 120/20R05-20PPPP	88300213
LFC 120/25R05	25810120	VFC 125/25R05-20PPPP	88300214
LFC 232/25R05	25810320	VFC 340/40R05-32PPPP	88302508 (DN 25 not possible)
LFC 232/40R05	25810330	VFC 340/40R05-32PPPP	88302508

When replacing LFC with VFC, please note the overall length. Installation situation and dimensions modified.

4.1.1 Search for order number or type

LFC Order No.	LFC type designation
[Empty search results table]	



LFC is to be replaced by VFC/IFC

Hits:

0

VFC/IFC Order No.

VFC/IFC type designation

F
I
O
W
r
a



5 Flow rate

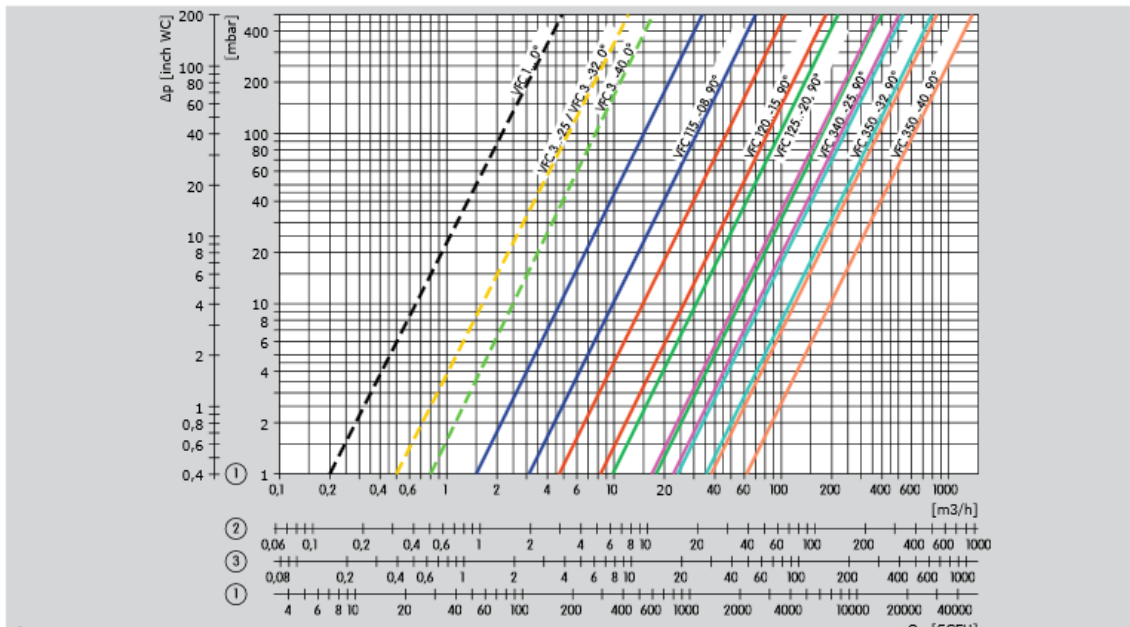

① = natural gas, $dv = 0.62$,

② = LPG, $dv = 1.56$,

③ = air, $dv = 1.00$.

The characteristic curves are measured at 15°C (59°F) with a measurement set-up in accordance with the standards EN 13611/EN 161. This involves measuring the pressure $5 \times$ DN upstream and downstream of the unit under test.

The pressure drop of the pipe is also measured but is not compensated for. Dotted line: max. flow rate with flow restricting cylinder closed. Left curve: Max. flow rate limited by flow restricting cylinder. Right curve: Max. flow rate with no limitation.



5.1 kv value

The size of the flow control cylinder is determined using the flow rate diagram or by calculation using the kv value.

$Q_{(n)}$ = flow rate (standard state) [m³/h]

k_v = valve coefficient

Δp = pressure loss [bar]

p_d = outlet pressure (absolute) [bar]

ρ_n = density [kg/m³] (air 1.29/natural gas 0.83/propane 2.01/butane 2.71)

T = medium temperature (absolute) [K]

$$k_v = \frac{Q_{(n)}}{514} \cdot \sqrt{\frac{\rho_n \cdot T}{\Delta p \cdot p_d}} \quad Q_{(n)} = 514 \cdot k_v \cdot \sqrt{\frac{\Delta p \cdot p_d}{\rho_n \cdot T}}$$

$$\Delta p = \left(\frac{Q_{(n)}}{514 \cdot k_v} \right)^2 \cdot \frac{\rho_n \cdot T}{p_d}$$

Type	k _v value		
	Closed	Open, restricted	Open, not restricted
VFC 115/15-08	0.2	1.38	2.87
VFC 120/25-15	0.2	4.31	7.55
VFC 125/25-20	0.2	8.92	16.30
VFC 340/40-25	0.5	15.41	20.68
VFC 350/50-32	0.5	21.92	32.46
VFC 350/50-40	0.7	34.75	56.63

The flow rate can be set using the integrated flow restricting cylinder.

Example

We want to find the size of the flow control cylinder for a linear flow control VFC.

We have the maximum flow rate $Q_{(n) \text{ max.}}$, the inlet pressure p_u and the temperature T for the medium of natural gas.

$Q_{(n) \text{ max.}} = 20 \text{ m}^3/\text{h}$

$p_u = 43 \text{ mbar} = 0.043 \text{ bar} \rightarrow$

$p_u \text{ absolute} = 0.043 \text{ bar} + 1.013 \text{ bar} = 1.056 \text{ bar}$

$\Delta p_{\text{max.}} = 0.013 \text{ bar (desired)}$

$p_d \text{ absolute} = p_u \text{ absolute} - \Delta p_{\text{max.}}$

$p_d \text{ absolute} = 1.056 \text{ bar} - 0.013 \text{ bar} = 1.043 \text{ bar}$

$= 27^\circ\text{C} \rightarrow$

$T_{\text{absolute}} = 27 + 273 \text{ K} = 300 \text{ K}$

$$k_v = \frac{20}{514} \cdot \sqrt{\frac{0.83 \cdot 300}{0.013 \cdot 1.043}} = 5.27$$

The VFC with the next higher k_v value is to be selected (see table on the left): VFC 1..-15.



บริษัท เอดีดี เฟอร์เนส จำกัด

ADD FURNACE CO.,LTD.

44 ซอยบรมราชชนนี 70 ถนนบรมราชชนนี แขวงศาลาธรรมสพน์ เขตทวีวัฒนา กรุงเทพฯ 10170

โทร: 02-888-3472 โทร: ออกแบบ:08-08-170-170 แฟกซ์: 02-888-3258

https://www.add-furnace.com E-mail: sales@add-furnace.com

6 Selection

6.1 Selection table

6.1.1 IFC

Type	Outlet flange nominal size	Accessories on right-hand side equivalent to those on left-hand side																																												
		Inlet																			Outlet																									
		R	N	F	05	08	15	20	25	32	40	P	M	1	2	3	4	P	M	1	2	3	4	/20/40	-07	-15	-30	-60	W	Q	A	2	3	T	E	D	A	R10								
IFC1-	/-	○	●	○	○	○	●	○	○	○	○	○	○	○	○	○	○	○	○	○	○	○	○	○	○	○	○	○	○	○	○	○	○	○	○	○	○	○	○	○						
IFC110	/10	●	●	○	○	○	○	○	○	○	○	○	○	○	○	○	○	○	○	○	○	○	○	○	○	○	○	○	○	○	○	○	○	○	○	○	○	○	○	○	○					
IFC115	/15	●	○	●	○	○	○	○	○	○	○	○	○	○	○	○	○	○	○	○	○	○	○	○	○	○	○	○	○	○	○	○	○	○	○	○	○	○	○	○	○	○				
IFC120	/20	●	●	○	○	○	○	○	○	○	○	○	○	○	○	○	○	○	○	○	○	○	○	○	○	○	○	○	○	○	○	○	○	○	○	○	○	○	○	○	○	○				
IFC125	/25	●	●	○	○	○	○	○	○	○	○	○	○	○	○	○	○	○	○	○	○	○	○	○	○	○	○	○	○	○	○	○	○	○	○	○	○	○	○	○	○	○				
IFC1T-	/-	○	●	○	○	○	○	○	○	○	○	○	○	○	○	○	○	○	○	○	○	○	○	○	○	○	○	○	○	○	○	○	○	○	○	○	○	○	○	○	○	○				
IFC1T10	/10	●	●	○	○	○	○	○	○	○	○	○	○	○	○	○	○	○	○	○	○	○	○	○	○	○	○	○	○	○	○	○	○	○	○	○	○	○	○	○	○	○	○			
IFC1T15	/15	●	●	○	○	○	○	○	○	○	○	○	○	○	○	○	○	○	○	○	○	○	○	○	○	○	○	○	○	○	○	○	○	○	○	○	○	○	○	○	○	○	○			
IFC1T20	/20	●	●	○	○	○	○	○	○	○	○	○	○	○	○	○	○	○	○	○	○	○	○	○	○	○	○	○	○	○	○	○	○	○	○	○	○	○	○	○	○	○	○	○		
IFC1T25	/25	●	●	○	○	○	○	○	○	○	○	○	○	○	○	○	○	○	○	○	○	○	○	○	○	○	○	○	○	○	○	○	○	○	○	○	○	○	○	○	○	○	○	○		
IFC3-	/-	○	●			○	○	○	○	○	○	○	○	○	○	○	○	○	○	○	○	○	○	○	○	○	○	○	○	○	○	○	○	○	○	○	○	○	○	○	○	○	○	○		
IFC340	/40	●	●			○	○	○	○	○	○	○	○	○	○	○	○	○	○	○	○	○	○	○	○	○	○	○	○	○	○	○	○	○	○	○	○	○	○	○	○	○	○	○	○	
IFC350	/50	●	○	●			○	○	○	○	○	○	○	○	○	○	○	○	○	○	○	○	○	○	○	○	○	○	○	○	○	○	○	○	○	○	○	○	○	○	○	○	○	○	○	
IFC365	/65	●	●				○	○	○	○	○	○	○	○	○	○	○	○	○	○	○	○	○	○	○	○	○	○	○	○	○	○	○	○	○	○	○	○	○	○	○	○	○	○	○	
IFC3T-	/-	○	●			○	○	○	○	○	○	○	○	○	○	○	○	○	○	○	○	○	○	○	○	○	○	○	○	○	○	○	○	○	○	○	○	○	○	○	○	○	○	○	○	○
IFC3T40	/40	●	●			○	○	○	○	○	○	○	○	○	○	○	○	○	○	○	○	○	○	○	○	○	○	○	○	○	○	○	○	○	○	○	○	○	○	○	○	○	○	○	○	○
IFC3T50	/50	●	●				○	○	○	○	○	○	○	○	○	○	○	○	○	○	○	○	○	○	○	○	○	○	○	○	○	○	○	○	○	○	○	○	○	○	○	○	○	○	○	○
IFC3T65	/65	●	●				○	○	○	○	○	○	○	○	○	○	○	○	○	○	○	○	○	○	○	○	○	○	○	○	○	○	○	○	○	○	○	○	○	○	○	○	○	○	○	○

● = standard, ○ = available

Order example

IFC 115/15R05-15PPPP/20-60W3T



บริษัท เอดีดี เฟอร์เนส จำกัด

ADD FURNACE CO.,LTD.

44 ซอยบรมราชชนนี 70 ถนนบรมราชชนนี แขวงศาลาธรรมสพน์ เขตทวีวัฒนา กรุงเทพฯ 10170

โทร: 02-888-3472 โทร: ออกแบบ:08-08-170-170 แฟกซ์: 02-888-3258

https://www.add-furnace.com E-mail: sales@add-furnace.com

6.1.2 VFC

Typ	Outlet flange nominal size																Accessories on right-hand side equivalent to those on left-hand side																				
	/-	/10	/15	/20	/25	/40	/50	/65	R	N	F	05	-08	-15	-20	-25	-32	-40	Inlet				Outlet														
																			P	M	1	2	3	4	P	M	1	2	3	4							
VFC 1-	●	○	○	○	○			○				●	○	○	●					●	○	○	○	○	○	○	○	○	○	○	○	○	○	○	○		
VFC 110	○	●	○	○	○			●				●	●	○	○					●	○	○	○	○	○	○	○	○	○	○	○	○	○	○	○		
VFC 115	○	○	●	○	○			●				●	○	●	○					●	○	○	○	○	○	○	○	○	○	○	○	○	○	○	○		
VFC 120	○	○	○	●	○			●				●	○	○	●					●	○	○	○	○	○	○	○	○	○	○	○	○	○	○	○		
VFC 125	○	○	○	○	●			●				●	○	○	●					●	○	○	○	○	○	○	○	○	○	○	○	○	○	○	○		
VFC 1T-	●	○	○	○	○			○				●	○	○	●					●	○	○	○	○	○	○	○	○	○	○	○	○	○	○	○		
VFC 1T10	○	●	○	○	○			●				●	●	○	○					●	○	○	○	○	○	○	○	○	○	○	○	○	○	○	○		
VFC 1T15	○	○	●	○	○			●				●	○	●	○					●	○	○	○	○	○	○	○	○	○	○	○	○	○	○	○		
VFC 1T20	○	○	○	●	○			●				●	○	○	●					●	○	○	○	○	○	○	○	○	○	○	○	○	○	○	○		
VFC 1T25	○	○	○	○	●			●				●	○	○	●					●	○	○	○	○	○	○	○	○	○	○	○	○	○	○	○	○	
VFC 3-	●					○	○	○	○			●				○	●	○		●	○	○	○	○	○	○	○	○	○	○	○	○	○	○	○	○	
VFC 340	○					●	○	○	●			●				●	○	○		●	○	○	○	○	○	○	○	○	○	○	○	○	○	○	○	○	
VFC 350	○					○	●	○	●	○		●				○	●	○		●	○	○	○	○	○	○	○	○	○	○	○	○	○	○	○	○	
VFC 365	○					○	○	●	●			●				○	○	●		●	○	○	○	○	○	○	○	○	○	○	○	○	○	○	○	○	○
VFC 3T-	●					○	○	○	○			●				○	●	○		●	○	○	○	○	○	○	○	○	○	○	○	○	○	○	○	○	○
VFC 3T40	○					●	○	○	●			●				●	○	○		●	○	○	○	○	○	○	○	○	○	○	○	○	○	○	○	○	○
VFC 3T50	○					○	●	○	●			●				○	●	○		●	○	○	○	○	○	○	○	○	○	○	○	○	○	○	○	○	○
VFC 3T65	○					○	○	●	●			●				○	○	●		●	○	○	○	○	○	○	○	○	○	○	○	○	○	○	○	○	○

● = standard, ○ = available

Order example

VFC 115/15R05-15PPPP



บริษัท เอดีดี เฟอร์เนส จำกัด

ADD FURNACE CO.,LTD.

44 ซอยบรมราชชนนี 70 ถนนบรมราชชนนี แขวงศาลาธรรมสพน์ เขตทวีวัฒนา กรุงเทพฯ 10170

โทร: 02-888-3472 โทร: ออกแบบ:08-08-170-170 แฟกซ์: 02-888-3258

https://www.add-furnace.com E-mail: sales@add-furnace.com

6.2 IFC, VFC type code

Code	Description
VFC	Linear flow control
IFC	Linear flow control with actuator
1	Size 1
3	Size 3
T	T-product
10, 15, 20, 25, 40, 50, 65	Inlet flange nominal size
-	No inlet flange
/10, /15, /20, /25, /40, /50,	Outlet flange nominal size
/65	
/-	No outlet flange
R	Rp internal thread
N	NPT internal thread
F	ISO flange
05	p _u max. 500 mbar
-08	Cylinder
-15	
-20	
-25	
-32	
-40	
P	Plug
M	Pressure test point
1	Pressure switch for gas DG 17VC
2	Pressure switch for gas DG 40VC
3	Pressure switch for gas DG 110VC
4	Pressure switch for gas DG 300VC
-	No accessories
	Accessories, right, outlet
P	Plug
M	Pressure test point
1	Pressure switch for gas DG 17VC
2	Pressure switch for gas DG 40VC
3	Pressure switch for gas DG 110VC
4	Pressure switch for gas DG 300VC
-	No accessories

Code	Description
	The same accessories can be selected for the left- or right-hand side.
/20	Actuator IC 20
/40	Actuator IC 40
	Running time [s]/90°:
-07	7.5
-15	15
-30	30
-60	60
	Mains voltage:
W	230 V AC, 50/60 Hz
Q	120 V AC, 50/60 Hz
A	100 – 230 V AC, 50/60 Hz
	Torque:
2	2.5 Nm
3	3 Nm
T	Three-point step control
E	0 (4) – 20 mA, 0 – 10 V continuous control
D	Digital input
A	4 – 20 mA analogue input
R10	1000 Ohm feedback Potentiometer
	Mounting actuator with electrical connection:
no specification	outlet side
-I	inlet side



บริษัท เอดีดี เฟอร์เนส จำกัด

ADD FURNACE CO.,LTD.

44 ซอยบรมราชชนนี 70 ถนนบรมราชชนนี แขวงศาลาธรรมสพน์ เขตทวีวัฒนา กรุงเทพฯ 10170

โทร: 02-888-3472 โทร: ออกแบบ:08-08-170-170 แฟกซ์: 02-888-3258

https://www.add-furnace.com E-mail: sales@add-furnace.com

6.3 Control characteristics

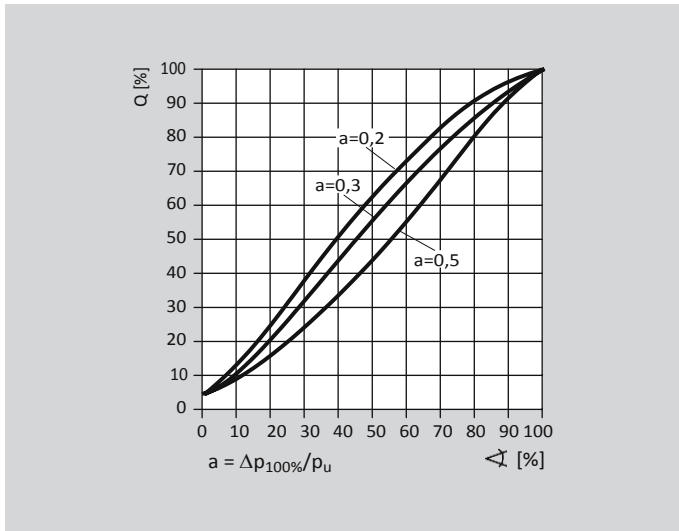

In order for the IFC to be able to influence the flow rate, a proportion of the pressure loss Δp of the entire system has to be caused by the linear flow control. Taking into consideration that the head losses Δp should be kept to a minimum, a control characteristic/valve authority $a = 0.3$ is recommended for the IFC. This means that of the overall inlet pressure, there is a 30% drop on the fully opened IFC.

Example

We want to find the IFC for gas to be used for modulating control of a gas burner:

The IFC is determined using the control characteristic a and the outlet pressure p_d .

Recommended control characteristic $a = 0.3$.

$$\Delta p = \frac{a \times p_d}{1 - a}$$

Outlet pressure: $p_d = 30$ mbar

Gas flow rate: $Q_{(n)} = 20$ m³/h

Control characteristic: $a = 0.3$

$$\frac{0.3 \times 30 \text{ mbar}}{1 - 0.3} = 12.9 \text{ mbar} \approx 13 \text{ mbar}$$

$$P = 1 - 0.3$$

Select the appropriate IFC for the required flow rate $Q_{(n)} = 20$ m³/h and reduced $p = 13$ mbar:

IFC 1..-15, see **P1** in the flow rate diagram (page 10).



บริษัท เอดีดี เฟอร์เนส จำกัด

ADD FURNACE CO.,LTD.

44 ซอยบรมราชชนนี 70 ถนนบรมราชชนนี แขวงศาลาธรรมสพน์ เขตทวีวัฒนา กรุงเทพฯ 10170

โทร: 02-888-3472 โทร: ออกแบบ:08-08-170-170 แฟกซ์: 02-888-3258

<https://www.add-furnace.com> E-mail: sales@add-furnace.com

7 Project planning information

The inlet pressure p_u and the outlet pressure p_d can be measured at the pressure test points.

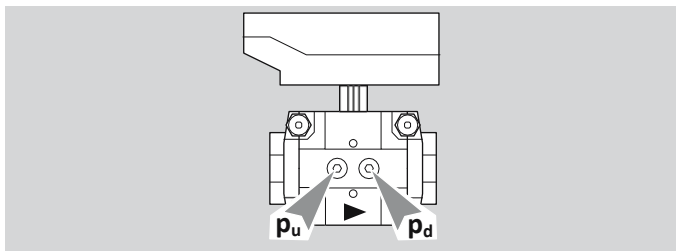

7.1 Installation

Actuators IC 20, IC 30, IC 40 and the linear flow control VFC must not be in contact with masonry. Minimum clearance 20 mm (0.787 inch).

Do not store or install the unit in the open air.

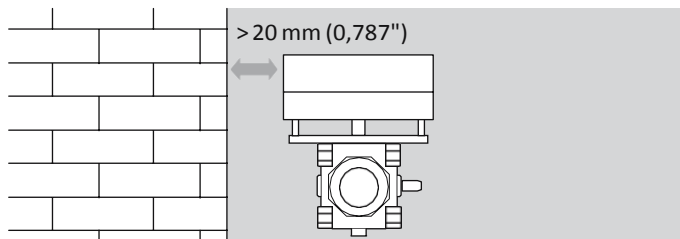

Sealing material and thread cuttings must not be allowed to get into the flow body. A filter or dirt trap must be installed upstream of every system.

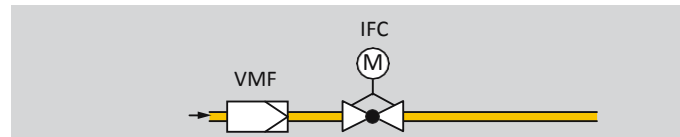

7.1.1 IC 20, IC 40 with VFC

Linear flow control VFC and actuators IC 20 and IC 40 can be supplied separately or assembled. Easy assembly with the actuator using 2 screws can be carried out either before or after installation of the linear flow control in the pipework.

Installation of IC 20, IC 40 in the vertical or horizontal position, not upside down.

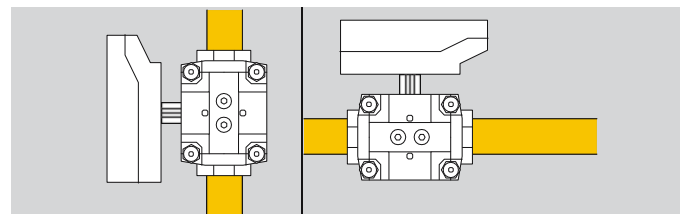

7.1.2 IC 30 with VFC

Linear flow control VFC and actuator IC 30 are supplied separately. IC 30 can be installed in any position.



บริษัท เอดีดี เฟอร์เนส จำกัด

ADD FURNACE CO.,LTD.

44 ซอยบรมราชชนนี 70 ถนนบรมราชชนนี แขวงศาลาธรรมสพน์ เขตทวีวัฒนา กรุงเทพฯ 10170

โทร: 02-888-3472 โทร: ออกแบบ:08-08-170-170 แฟกซ์: 02-888-3258

https://www.add-furnace.com E-mail: sales@add-furnace.com

8 Accessories

8.1 Pressure switches for gas

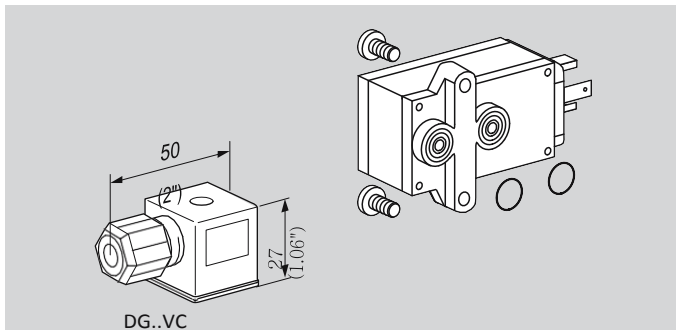

Type	Identification No. (see Selection table)	Adjusting range [mbar/hPa]
DG 17/VC-6W	1	2 – 17
DG 17/VC-6WG	1	2 – 17
DG 40/VC-6W	2	5 – 40
DG 40/VC-6WG	2	5 – 40
DG 110/VC-6W	3	30 – 110
DG 110/VC-6WG	3	30 – 110
DG 300/VC-6W	4	100 – 300
DG 300/VC-6WG	4	100 – 300

Scope of delivery:

- 1 x pressure switch for gas, 2 x retaining screws,
- 2 x sealing rings.

8.1.2 Attachment to IFC

Monitoring the inlet pressure p_u : the electrical plug of the pressure switch for gas points towards the inlet flange.

Monitoring the outlet pressure p_d : the electrical plug of the pressure switch for gas points towards the outlet flange.

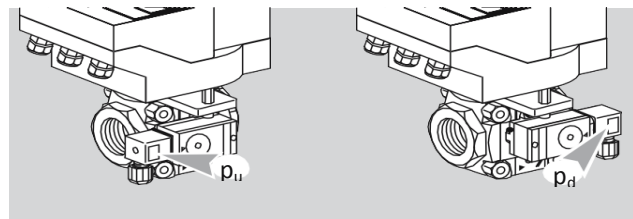

8.2 Pressure test points

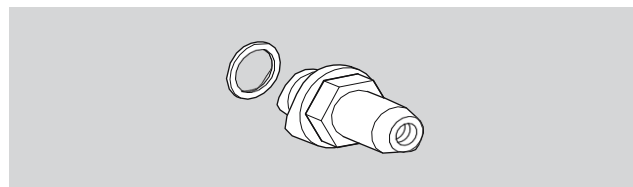

Test points to check the inlet pressure p_u and outlet pressure p_d .

Scope of delivery: 1 x test point with 1 x profiled sealing ring,

Order No. 74923390



บริษัท เอดีดี เฟอร์เนส จำกัด

ADD FURNACE CO.,LTD.

44 ซอยบรมราชชนนี 70 ถนนบรมราชชนนี แขวงศาลาธรรมสพน์ เขตทวีวัฒนา กรุงเทพฯ 10170

โทร: 02-888-3472 โทร: ออกแบบ:08-08-170-170 แฟกซ์: 02-888-3258

<https://www.add-furnace.com> E-mail: sales@add-furnace.com

8.3 Seal set VA

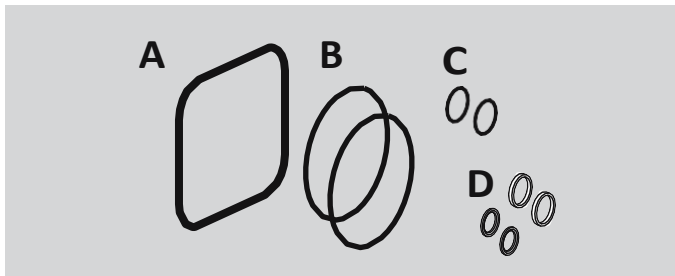

VA 1, Order No. 74921988,

VA 3, Order No. 74921990.

Scope of delivery:

A 1 x double block seal (this is not required for VFC),

B 2 x O-rings (flange),

C 2 x O-rings (pressure switch),

for pressure test point/screw

plug:

D 2 x sealing rings (flat sealing) and 2 x profiled sealing rings.

8.4 Fastening set IC 20, IC 40

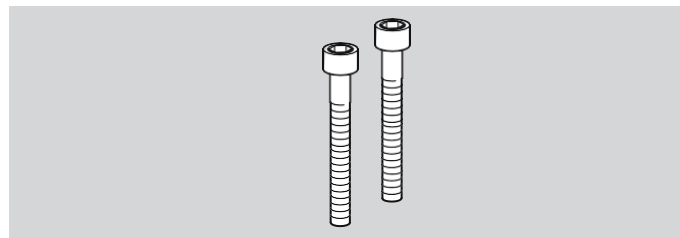

To attach an IC 20 or IC 40 to the linear flow control VFC.

The fastening set is delivered enclosed as an additional item.

IC-BVG/BVA/BVH/VFC /B, Order No. 74921082

8.5 Adapter set IC 30

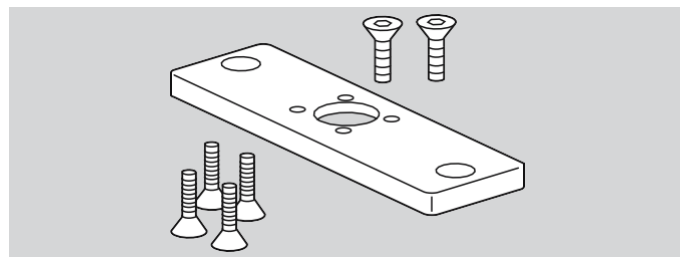

To attach the IC 30 to the linear flow control VFC.

The adapter set is delivered enclosed as an additional item.

IC 30/VFC /B, Order No. 74340194



บริษัท เอดีดี เฟอร์เนส จำกัด

ADD FURNACE CO.,LTD.

44 ซอยบรมราชชนนี 70 ถนนบรมราชชนนี แขวงศาลาธรรมสพน์ เขตทวีวัฒนา กรุงเทพฯ 10170

โทร: 02-888-3472 โทร: ออกแบบ:08-08-170-170 แฟกซ์: 02-888-3258

https://www.add-furnace.com E-mail: sales@add-furnace.com

9 Technical data

9.1 VFC

Gas types: natural gas, LPG (gaseous), biogas (max. 0.1 %-by-vol. H₂S) or clean air; other types of gas on request. The gas must be dry in all temperature conditions and must not contain condensate.

Control ratio: 25:1.

Leakage rate: < 2% of k_{vs} value.

Max. inlet pressure p_{u max.}: 500 mbar (7.25 psi).

Connection flanges: Rp internal thread pursuant to ISO 7-1.

Housing material: aluminium,
control cylinder: aluminium, flow
restricting cylinder: POM, seal:
HNBR/NBR.

Ambient temperature: -20 to +60°C (-4 to +140°F).

Storage temperature: -20 to +40°C (-4 to +104°F).

Installation position as required; in conjunction with IC in the vertical upright position or tilted up to the horizontal, not upside down.

9.2 IC 20, IC 20..E

Line entrance for electrical connection:

3 x M20 plastic cable glands.

Screw terminals using the elevator principles for cables up to 4 mm² (single core cables) and for cables up to 2.5 mm² with wire end ferrules.

Typical designed lifetime:

Switching current	Switching cycles	
	cos = 1	cos = 0.3
1 mA	1,000,000	–
22 mA ¹⁾	–	1,000,000
100 mA	1,000,000	–
2 A	100,000	–

Three-point step signal to terminals 1 and 2:

minimum pulse duration: 100 ms,

minimum pause between 2 pulses: 100 ms.

Enclosure: IP 65, safety class: I.

Ambient temperature:

-20 to +60°C (-4 to +140°F), no condensation permitted.

Storage temperature: -20 to +40°C (-4 to +104°F).

Mains voltage:

120 V AC, -15/+10%, 50/60 Hz,

230 V AC, -15/+10%, 50/60 Hz.

Type	Running time [s/90°]		Torque [Nm]	
	50 Hz	60 Hz	50 Hz	60 Hz
IC 20-07	7.5	6.25	2.5	2
IC 20-15	15	12.5	3	3
IC 20-30	30	25	3	3
IC 20-60	60	50	3	3



บริษัท เอดีดี เฟอร์เนส จำกัด

ADD FURNACE CO.,LTD.

44 ซอยบรมราชชนนี 70 ถนนบรมราชชนนี แขวงศาลาธรรมสพน์ เขตทวีวัฒนา กรุงเทพฯ 10170

โทร: 02-888-3472 โทร: ออกแบบ:08-08-170-170 แฟกซ์: 02-888-3258

<https://www.add-furnace.com> E-mail: sales@add-furnace.com

9.2.1 IC 20

Power consumption:

4.9 VA at 50 Hz, 5.8 VA at 60 Hz.

Resistance of the feedback potentiometer: 1 k Ω , max. 1 W.

9.2.2 IC 20.E

Power consumption: terminals

1, 2 and 5:

4.9 VA at 50 Hz, 5.8 VA at 60 Hz,

terminal 3:

8.4 VA at 50 Hz, 9.5 VA at 60 Hz, in

total not exceeding:

8.4 VA at 50 Hz, 9.5 VA at 60 Hz.

Position feedback output:

4 – 20 mA, electrically isolated, max. 500 Ω load impedance.

The output is always active when supply voltage is applied to terminals 3 and 4.

Input: electrically isolated,

0 (4) – 20 mA: load impedance switchable between 50 Ω and 250 Ω ,

0 – 10 V: 100 k Ω input resistance.

9.3 IC 30

Mains voltage: 24

V DC, $\pm 20\%$.

Line entrance: 3 x M16 plastic cable glands (enclosed).

Screw terminals using the elevator principles for cables up to 2.5 mm² with wire end ferrules.

The running time changes depending on the load. It refers to the torque, see type label.

Contact rating of the cam switches:

Voltage	Min. current (resistive load)	Max. current (resistive load)
24 – 230 V, 50/60 Hz	1 mA	2 A
24 V DC	1 mA	100 mA

Enclosure: IP 65.

Duty cycle: 100%. Ambient

temperature:

-15 to +60°C (5 to 140°F), no condensation permitted.

Storage temperature: -15 to +40°C (5 to 104°F).

Resistance of the feedback potentiometer: 1

k Ω , < 50 V,

recommended wiper current: 0.2 μ A.

9.4 IC 40

Mains voltage:

100 – 230 V AC, $\pm 10\%$, 50/60 Hz, the actuator automatically adjusts to the respective mains voltage.

Power consumption: 8.4 W,

switch-on peak current: max. 8 A for max. 10 ms.

Screw terminals using the elevator principles for cables up to 4 mm² (single core cables) and for cables up to 2.5 mm² with wire end

ferrules. Angle of rotation: 0 –

90°.



บริษัท เอดีดี เฟอร์เนส จำกัด

ADD FURNACE CO.,LTD.

44 ซอยบรมราชชนนี 70 ถนนบรมราชชนนี แขวงศาลาธรรมสพน์ เขตทวีวัฒนา กรุงเทพฯ 10170

โทร: 02-888-3472 โทร: ออกแบบ:08-08-170-170 แฟกซ์: 02-888-3258

<https://www.add-furnace.com> E-mail: sales@add-furnace.com

Holding torque = torque as long as permanent supply voltage is applied.

2 digital inputs:

24 V DC or 100 – 230 V AC each.

Current requirement of digital inputs: 3 mA ± 1.5 mA.

1 analogue input (optional): 4 – 20 mA (internal load impedance: max. 500 Ω at 20 mA).

Potentiometer (optional):

1000 Ω +/- 20%,

linearity tolerance +/- 2%,

max. capacity 0.25 W,

conductive plastic element.

2 digital outputs:

Signalling contacts designed as relay change-over contacts. Contact current of digital outputs: min. 5 mA (resistive) and max. 2 A.

The relay contacts can be connected to 100 – 230 V AC or 24 V DC. If the contacts have been connected with a voltage > 24 V and a current > 0.1 A once, the gold plating on the contacts will have been burnt through. This contact can then only be connected with this power rating or higher power rating.

2 LED status displays:

- Blue LED for operation “ON”;
actuator in motion = slow flashing light; manual operation = fast flashing light; actuator stopped = permanent light.

- Red LED for warnings and faults;
warning = permanent light;
fault = flashing light.
- Red and blue LED simultaneously,
calibration in progress = flashing light.

Enclosure: IP 65. Safety

class: I.

Line entrance for electrical connection:

3 x M20 plastic cable glands.

Ambient temperature:

-20 to +60°C (-4 to +140°F), no condensation permitted.

Storage temperature: -20 to +40°C (-4 to +104°F).

9.4.1 Running times and torques

Type	Running time [s/90°]		Torque [Nm]	
	50 Hz	60 Hz	50 Hz	60 Hz
IC 40	4.5 – 76.5	4.5 – 76.5	2.5	2.5

On the IC 40, the running time and torque are independent of the mains frequency. The running time can be freely programmed between the limits of 4.5 and 76.5 s.



บริษัท เอดีดี เฟอร์เนส จำกัด

ADD FURNACE CO.,LTD.

44 ซอยบรมราชชนนี 70 ถนนบรมราชชนนี แขวงศาลาธรรมสพน์ เขตทวีวัฒนา กรุงเทพฯ 10170

โทร: 02-888-3472 โทร: ออกแบบ:08-08-170-170 แฟกซ์: 02-888-3258

https://www.add-furnace.com E-mail: sales@add-furnace.com

9.5 Dimensions of IFC [mm]

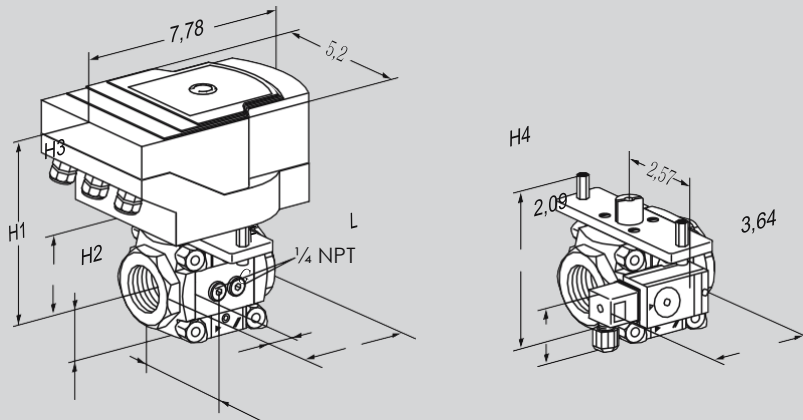

Type	Connection		L mm	F mm	G mm	H1 mm	H2 mm	H3 mm	H4 mm	Weigh t kg
	Rp	DN								
IFC 110	3/8	10	75	15	67.3	155	37.5	58	95.5	2.65
IFC 115	1/2	15	75	15	67.3	155	37.5	58	95.5	2.60
IFC 120	3/4	20	91	23	67.3	155	37.5	58	95.5	2.75
IFC 125	1	25	91	23	67.3	155	37.5	58	95.5	2.65
IFC 340	1½	40	154.5	36	113.3	181	59	84	143	4.92
IFC 350	2	50	154.5	36	113.3	181	59	84	143	4.75
IFC 365	2½	65	154.5	36	113.3	181	59	84	143	4.45
IFC 350..F	-	50	230.5	74	113.3	181	59	84	143	6.81



บริษัท เอดีดี เฟอร์เนส จำกัด

ADD FURNACE CO.,LTD.

44 ซอยบรมราชชนนี 70 ถนนบรมราชชนนี แขวงศาลาธรรมสพน์ เขตทวีวัฒนา กรุงเทพฯ 10170

โทร: 02-888-3472 โทร: ออกแบบ:08-08-170-170 แฟกซ์: 02-888-3258

<https://www.add-furnace.com> E-mail: sales@add-furnace.com

9.6 Dimensions of VFC with IC 30 [mm]

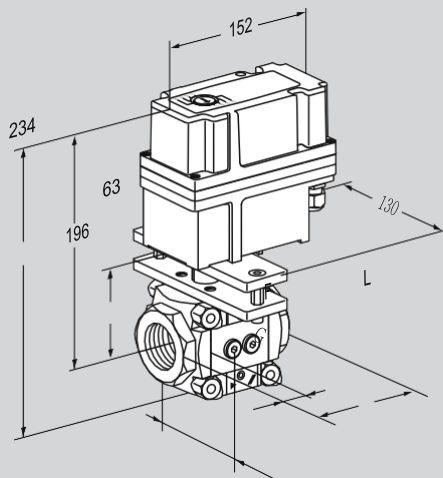

Type	Connection		L mm	F mm	G mm
	Rp	DN			
VFC 110	3/8	10	75	15	67.3
VFC 115	1/2	15	75	15	67.3
VFC 120	3/4	20	91	23	67.3
VFC 125	1	25	91	23	67.3
VFC 340	1½	40	154.5	36	113.3
VFC 350	2	50	154.5	36	113.3
VFC 365	2½	65	154.5	36	113.3
VFC 350..F	-	50	230.5	74	113.3



บริษัท เอดีดี เฟอร์เนส จำกัด

ADD FURNACE CO.,LTD.

44 ซอยบรมราชชนนี 70 ถนนบรมราชชนนี แขวงศาลาธรรมสพน์ เขตทวีวัฒนา กรุงเทพฯ 10170

โทร: 02-888-3472 โทร: ออกแบบ:08-08-170-170 แฟกซ์: 02-888-3258

https://www.add-furnace.com E-mail: sales@add-furnace.com

9.7 Dimensions of IFC [inch]

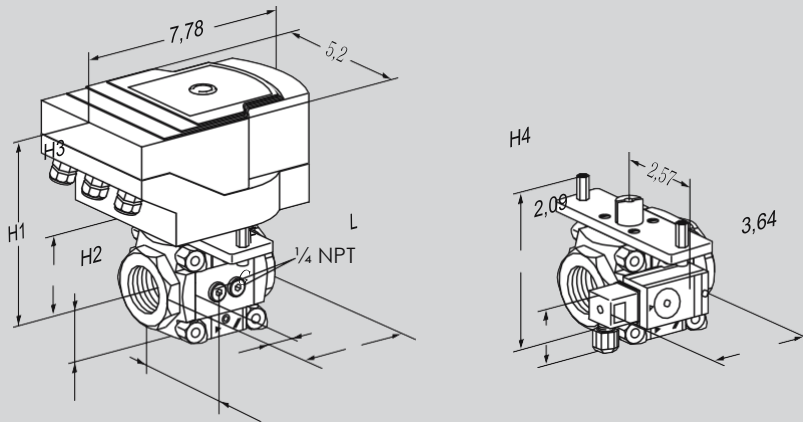

Type	Connection		L inch	F inch	G inch	H1 inch	H2 inch	H3 inch	H4 inch	Weigh ↑ lbs
	NPT	DN								
IFC 1T10	3/8	10	2.95	0.59	2.65	6.1	1.48	2.28	3.76	5.83
IFC 1T15	1/2	15	2.95	0.59	2.65	6.1	1.48	2.28	3.76	5.72
IFC 1T20	3/4	20	3.58	0.91	2.65	6.1	1.48	2.28	3.76	6.05
IFC 1T25	1	25	3.58	0.91	2.65	6.1	1.48	2.28	3.76	5.83
IFC 3T40	1½	40	6.08	1.42	4.46	7.13	2.32	3.31	5.63	10.8
IFC 3T50	2	50	6.08	1.42	4.46	7.13	2.32	3.31	5.63	10.5
IFC 3T65	2½	65	6.08	1.42	4.46	7.13	2.32	3.31	5.63	9.79



บริษัท เอดีดี เฟอร์เนส จำกัด

ADD FURNACE CO.,LTD.

44 ซอยบรมราชชนนี 70 ถนนบรมราชชนนี แขวงศาลาธรรมสพน์ เขตทวีวัฒนา กรุงเทพฯ 10170

โทร: 02-888-3472 โทร: ออกแบบ:08-08-170-170 แฟกซ์: 02-888-3258

<https://www.add-furnace.com> E-mail: sales@add-furnace.com

9.8 Dimensions of VFC with IC 30 [inch]

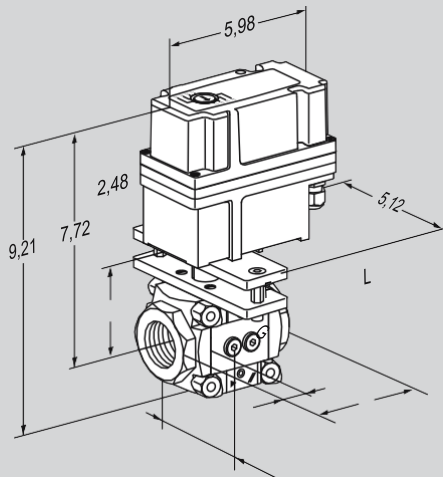

Type	Connection		L inc h	F inc h	G inc h
	NPT	DN			
VFC 1T10	3/8	10	2.95	0.59	2.65
VFC 1T15	1/2	15	2.95	0.59	2.65
VFC 1T20	3/4	20	3.58	0.91	2.65
VFC 1T25	1	25	3.58	0.91	2.65
VFC 3T40	1½	40	6.08	1.42	4.46
VFC 3T50	2	50	6.08	1.42	4.46
VFC 3T65	2½	65	6.08	1.42	4.46