



บริษัท เอดีดี เฟอร์เนส จำกัด

ADD FURNACE CO.,LTD.

44 ซอยบรมราชชนนี 70 ถนนบรมราชชนนี แขวงศาลาธรรมสพน์ เขตทวีวัฒนา กรุงเทพฯ 10170

โทร: 02-888-3472 โทร: ออกแบบ:08-08-170-170 แฟกซ์: 02-888-3258

<https://www.add-furnace.com> E-mail: sales@add-furnace.com

PMA Prozeß- und Maschinen-Automation GmbH



Universal controller for burners KS40-1 burner



Operating manual

English

9499-040-66011

Valid from:8473

expert line
expert line



บริษัท เอดีดี เฟอร์เนส จำกัด

ADD FURNACE CO.,LTD.

44 ซอยบรมราชชนนี 70 ถนนบรมราชชนนี แขวงศาลาธรรมสพน์ เขตทวีวัฒนา กรุงเทพฯ 10170

โทร: 02-888-3472 โทร: ออกแบบ:08-08-170-170 แฟกซ์: 02-888-3258

<https://www.add-furnace.com> E-mail: sales@add-furnace.com

**Description of
symbols in the text:**

- g General information
- a General warning
- l Attention: ESD-sensitive devices

on the device:

- a Follow the operating instructions

© PMA Prozeß- und Maschinen-Automation GmbH □ Printed in Germany (0207) All rights reserved. No part of this document may be reproduced or published in any form or by any means without prior written permission from the copyright owner.

A publication of PMA Prozeß- und Maschinen Automation
P.O.Box 310229
D-34058 Kassel
Germany



Contents

1	Mounting	5
2	Electrical connections	6
3	Operation	7
3.1	Front view.	7
3.2	Operating level	8
3.3	Self-tuning	10
3.4	Manual tuning	11
3.5	Operating structure	13
4	Configuration level	14
4.1	Configuration with qUIC.	14
4.2	Configuration without qUIC (qUIC= OFF)	18
4.3	Configuration survey:	18
5	Parameter setting level	24
5.1	Input scaling (only visible with qUIC = OFF)	26
6	Calibration level	27
7	Programmer	30
8	Technical data	32
9	Safety hints	36
9.1	Resetting to factory setting	38



บริษัท เอดีดี เฟอร์เนส จำกัด

ADD FURNACE CO.,LTD.

44 ซอยบรมราชชนนี 70 ถนนบรมราชชนนี แขวงศาลาธรรมสพน์ เขตทวีวัฒนา กรุงเทพฯ 10170

โทร: 02-888-3472 โทร: ออกแบบ:08-08-170-170 แฟกซ์: 02-888-3258

<https://www.add-furnace.com> E-mail: sales@add-furnace.com



1 Mounting

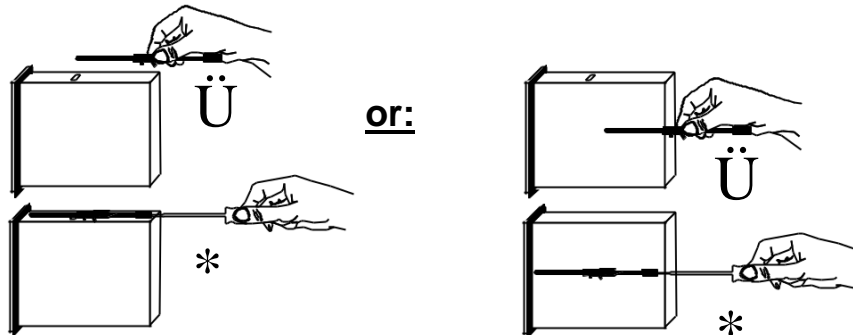
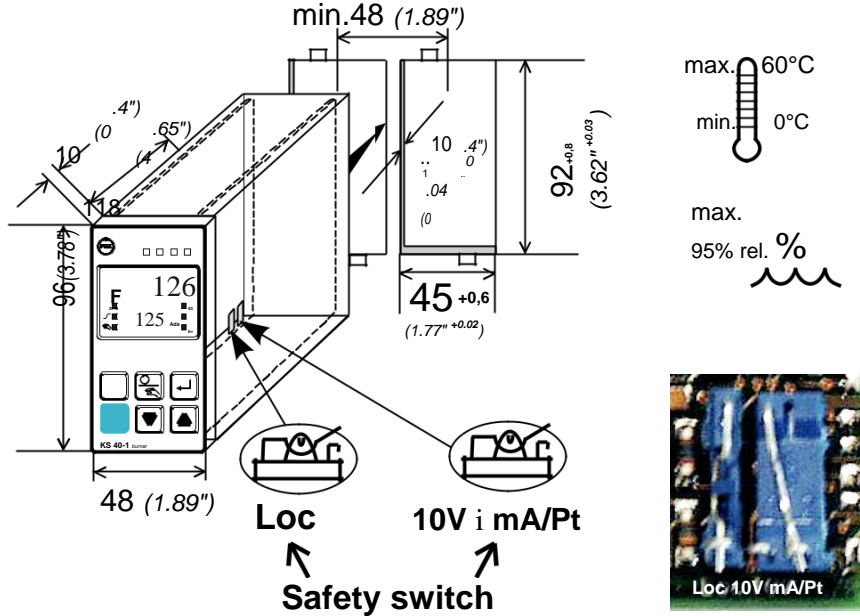

Safety switch:

For access to the safety switches, the controller must be withdrawn from the housing. Squeeze the top and bottom of the front bezel between thumb and forefinger and pull the controller firmly from the housing.

10V i mA/Pt	mA/Pt 1	Thermocouple / Pt100 or transducer at InP.1
	10V	Pressure transmitter (0..10V) at InP.1
Loc	open	Access to the levels is as adjusted by means of BlueControl (engineering tool) 2
	closed 1	all levels accessible without restriction

1 Factory setting

2 Default setting: display of all levels suppressed, password PASS = OFF

⚠ Safety switch 10V i mA/Pt always in position left or right. Leaving the safety switch open may lead to faulty functions!

⚠ Caution! The unit contains ESD-sensitive components.



Electrical connections

2 Electrical connections

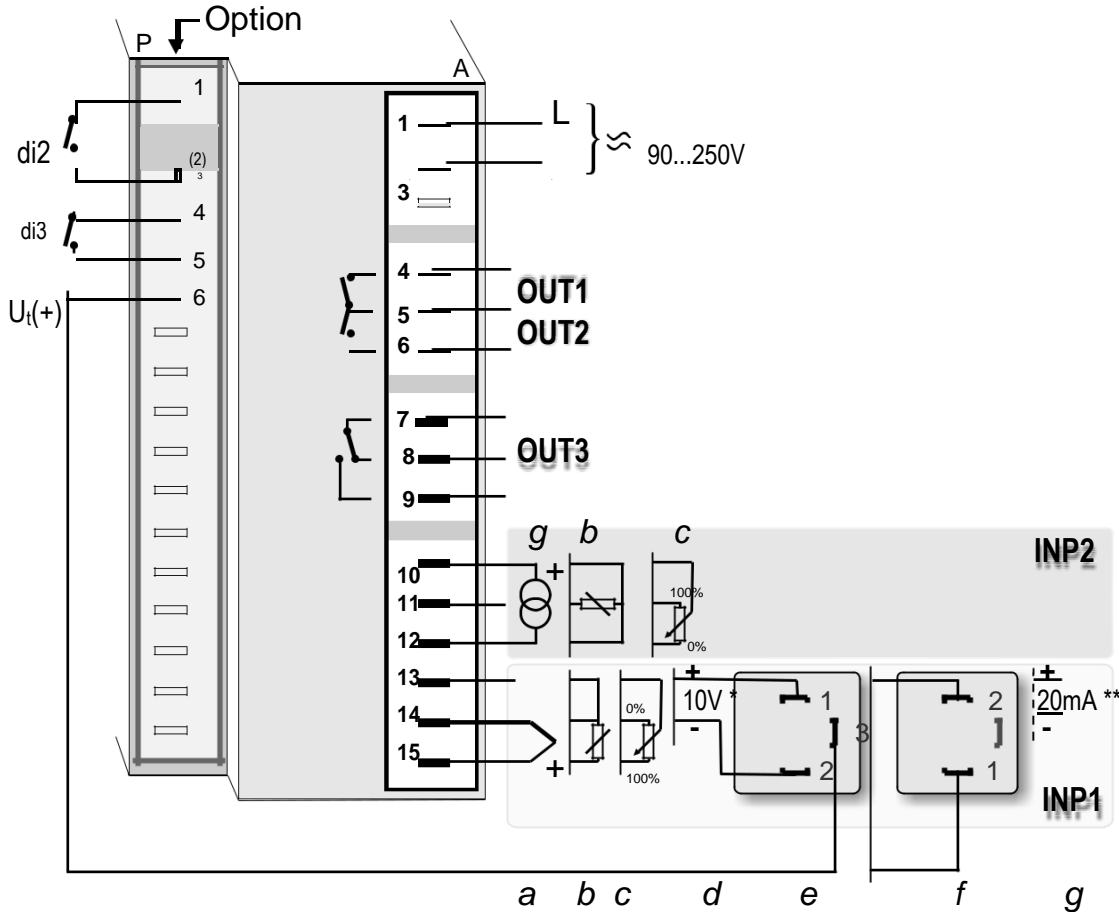

- * Safety switch INP1 (mA i 10V) in position 10V
- ** Safety switch INP1 (mA i 10V) in position mA/Pt

Connection of input INP1

Input for variable x1 (process value)

- a thermocouple
- b resistance thermometer (Pt100/ Pt1000/ KTY/ ...)
- c Transducer 50-30-50
- d voltage (0/2...10V)
- e pressure transmitter (3-wire connection)
- f pressure transmitter (2-wire connection)
- g current (0/4...20mA)

Connection of input INP2

See input INP1.

Connection of inputs di2/di3

Digital input di2 for external switching between SP and SP.2 (SP/SP2). Digital input di3 for external switching between 3-point-stepping controller and on/off controller (DPS/SG).



3 Operation

3.1 Front view

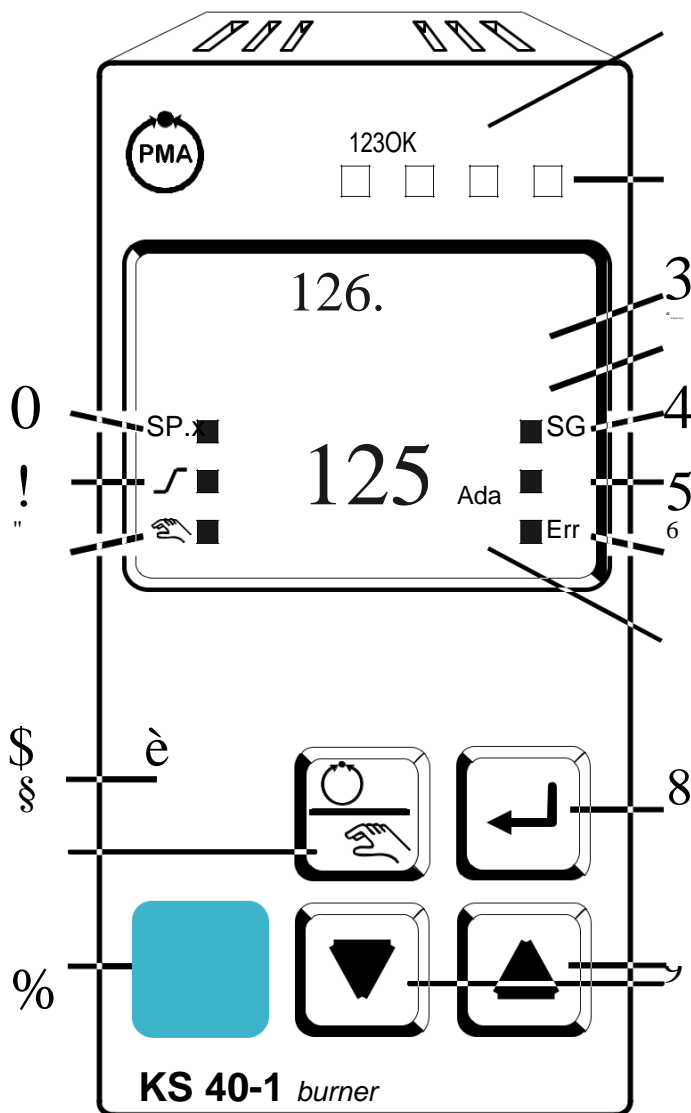

- 1 Status of switching outputs
- OuT.1... 3
- 1 2 Lit with limit value 1 not exceeded
- 3 Process value display
- 2 4 Controller works as on/off controller
- 5 Self-tuning active
- 6 Entry in error list
- 7 Set-point, controller output
- calls up extended operating level / error list
- 9 Up/down keys:
- changing the set-point or the controller output value
- 7^u Set-point SP.2 or SP.E is effective
- ! Set-point gradient effective
- " Manual mode
- § Function key
- \$ Manual-automatic-mode switching (")
- % PC connection for BlueControl (engineering tool)
- & Signalization
- PArA level (burns)
- ConF level (blinks)

 In the upper display line, the process value is always displayed. At parameter, configuration, calibration as well as extended operating level, the bottom display line changes cyclically between parameter name and parameter value.



Operation

3.2 Operating level

The content of the extended operating level is determined by means of BlueControl (engineering tool). Parameters which are used frequently or the display of which is important can be copied to the extended operating level.

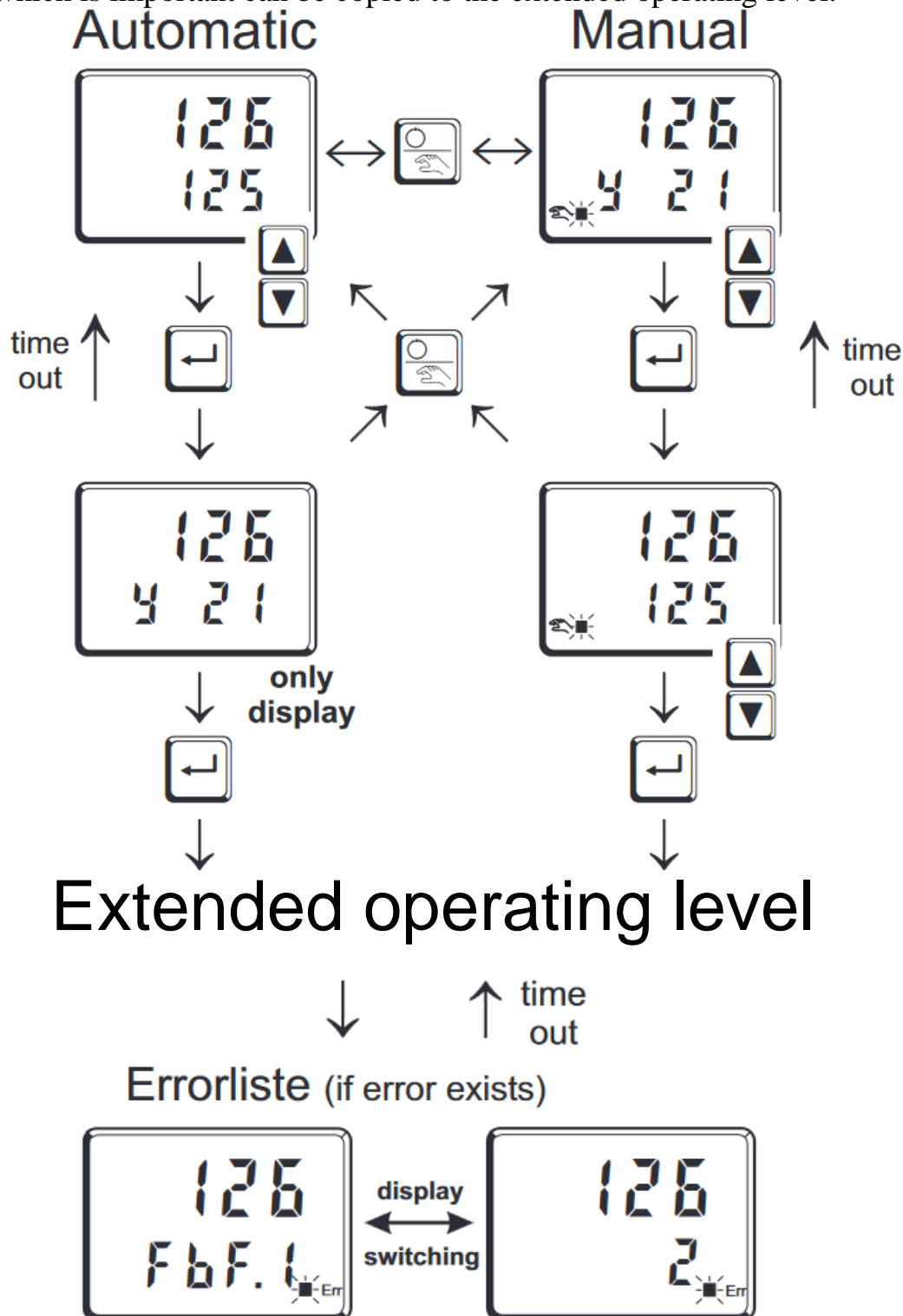

**Maintenance manager / Error list**

With one or several errors, the extended operating level always starts with the error list. Signalling an actual entry in the error list (alarm, error) is done by the Err LED

in the display. To reach the error list press Û twice.



Err LED status	Signification	Proceed as follows
blinks	Alarm due to existing error	Determine the error type in the error list via the error number - Remove the error
lit	Error removed, Alarm not acknowledged	Acknowledge the alarm in the error list pressing key E or I - The alarm entry was deleted.
off	No error,all alarm entries deleted	

Error list:

Name	Description	Cause	Possible remedial action
E.1	Internal error, cannot be removed	- E.g. defective EEPROM	- Contact PMA service - Return unit to our factory
E.2	Internal error, can be reset	- e.g. EMC trouble	- Keep measurement and power supply cables in separate runs - Ensure that interference suppression of contactors is provided
FbF.1 / 2	Sensor break INP1 / 2	- Sensor defective - Faulty cabling	- Replace INP1 / 2 sensor - Check INP1 / 2 connection
Sht.1 / 2	Short circuit INP1 / 2	- Sensor defective - Faulty cabling	- Replace INP1 / 2 sensor - Check INP1 / 2 connection
POL.1	INP1 polarity error	- Faulty cabling	- Reverse INP1 polarity
LooP	Control loop alarm (LOOP)	- Input signal defective or not connected correctly - Output not connected correctly	- Check heating or cooling circuit - Check sensor and replace it, if necessary - Check controller and switching device
AdA.H	Self-tuning heating alarm (ADAH)	- See Self-tuning heating error status	- see Self-tuning heating error status
LiM.1 / 2 / 3	stored limit alarm 1 / 2 / 3	- adjusted limit value 1 / 2 / 3 exceeded	- check process
Inf.1	time limit value message	- adjusted number of operating hours reached	- application-specific



Operation

Error status (error status 3 - 9 only with error AdA.H / AdA.C):

Error status	Signification
0	No error/message not visible, except with acknowledgement
1	Stored error Change to error status 0 after acknowledgement in error list
2	Existing error Change to error status 1 after error removal
3	Faulty control action Re-configure controller (inverse i direct)
4	No response of process variable The control loop is perhaps not closed: check sensor, connections and process
5	Low reversal point Increase (ADA.H) max. output limiting Y.Hi or decrease (ADA.C) min. output limiting Y.Lo
6	Danger of exceeded set-point (parameter determined) If necessary, increase (inverse) or reduce (direct) set-point
7	Output step change too small ($dy > 5\%$) Increase (ADA.H) max. output limiting Y.Hi or reduce (ADA.C) min. output limiting Y.Lo
8	Set-point reserve too small Increase set-point (invers), reduce set-point (direct) or increase set-point range (r PArA / SEtp / SP.LO and SP.Hi)
9	Impulse tuning failed The control loop is perhaps not closed: check sensor, connections and process

3.3 Self-tuning

After starting by the operator, the controller makes a self-tuning attempt. The controller uses the process characteristics for quick line-out to the set-point without overshoot.

 t_i and t_d are taken into account only, if they were not set to OFF previously.

Self-tuning start

The operator can start self-tuning at any time. For this, keys \bar{U} and \bar{E} must be pressed simultaneously. The AdA LED starts blinking.

The controller outputs 0% or Y.Lo, waits until the process is at rest and starts self-tuning (AdA LED lit permanently).

The self-tuning attempt is started when the following prerequisite is met:

- w The difference between process value i set-point must be 10% of the set-point range (SP.Hi - SP.LO) (with inverse action: process value smaller than set-point, with direct action: process value higher than set-point).

After successful self-tuning, the AdA-LED is off and the controller continues operating with the new control parameters.

Self-tuning cancellation by the operator:

Self-tuning can always be cancelled by the operator. For this, press \bar{U} and \bar{E} key simultaneously. The controller continues operating with the old parameters in automatic mode in the first case and in manual mode in the second case.



Self-tuning cancellation by the controller:

If the Err LED starts blinking while self-tuning is running, successful self-tuning is prevented due to the control conditions. In this case, self-tuning was cancelled by the controller. The controller switches off its outputs (controller output 0%).

Acknowledgement procedures in case of unsuccessful self-tuning:

1. Press keys \dot{U} and \dot{E} simultaneously:

The controller continues controlling using the old parameters in automatic mode. The Err LED continues blinking, until the self-tuning error was acknowledged in the error list.

2. Press key \dot{U} :

Display of error list at extended operating level. After acknowledgement of the error message, the controller continues control in automatic mode using the old parameters.

Cancellation causes:

page 9: "Error status self-tuning heating (ADA.H) and cooling (ADA.C)"

Examples for self-tuning attempt 3-point-stepping controller

After the start (1) the controller closes the actuator (2 Out.3). When the difference between process value and set-point is big enough (3), the changing of the process value is monitored for 1 min. (4). Afterwards the actuator is opened (5 Out.1). If the reversal point is reached (6) or there are made enough measurements, the parameters are detected and are adopted.

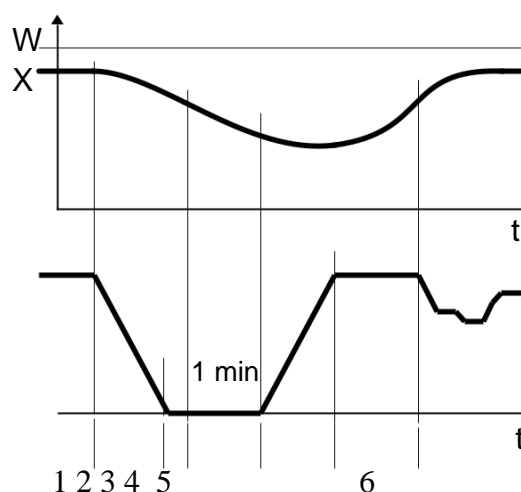

3.4 Manual tuning

The optimization aid should be used with units on which the control parameters shall be set without self-tuning.

For this, the response of process variable x after a step change of correcting variable y can be used. Frequently, plotting the complete response curve (0 to 100%) is not possible, because the process must be kept within defined limits.



Operation

Values T_g and x_{max} (step change from 0 to 100 %) or t and x (partial step response) can be used to determine the maximum rate of increase v_{max} .

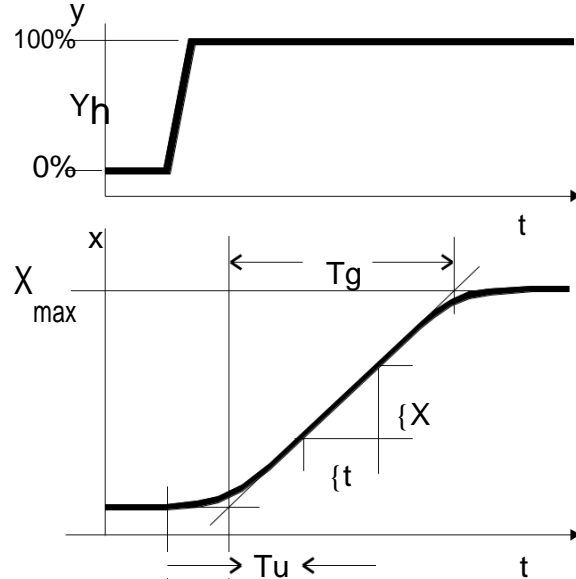

- y = correcting variable
- Y_h = control range
- T_u = delay time (s)
- T_g = recovery time (s)
- X_{max} = maximum process value

$$v_{max} = \frac{X_{max}}{T_g} = \frac{x}{t} = \text{max. rate of increase of process value}$$

The control parameters can be determined from the values calculated for delay time T_u , maximum rate of increase v_{max} , control range X_h and characteristic K according to the **formulas** given below. Increase X_p , if line-out to the set-point oscillates.

Parameter adjustment effects

Parameter	Control	Line-out of disturbances	Start-up behaviour
Pb1 higher	increased damping	slower line-out	slower reduction of duty cycle
lower	reduced damping	faster line-out	faster reduction of duty cycle
td1 higher	reduced damping	faster response to disturbances	faster reduction of duty cycle
lower	increased damping	slower response to disturbances	slower reduction of duty cycle
ti1 higher	increased damping	slower line-out	slower reduction of duty cycle
lower	reduced damping	faster line-out	faster reduction of duty cycle

Formulas

$$K = v_{max} * T_u$$

With 2-point and 3-point controllers, the cycle time must be adjusted to $t_1 / t_2 = 0,25 * T_u$

controller behavior	Pb1 [phy. units]	td1 [s]	ti1 [s]
PID	$1,7 * K$	$2 * T_u$	$2 * T_u$
PD	$0,5 * K$	T_u	OFF
PI	$2,6 * K$	OFF	$6 * T_u$
P	K	OFF	OFF
3-point-stepping	$1,7 * K$	T_u	$2 * T_u$



3.5 Operating structure

After supply voltage switch-on, the controller starts with the **operating levels**. The controller status is as before power off.

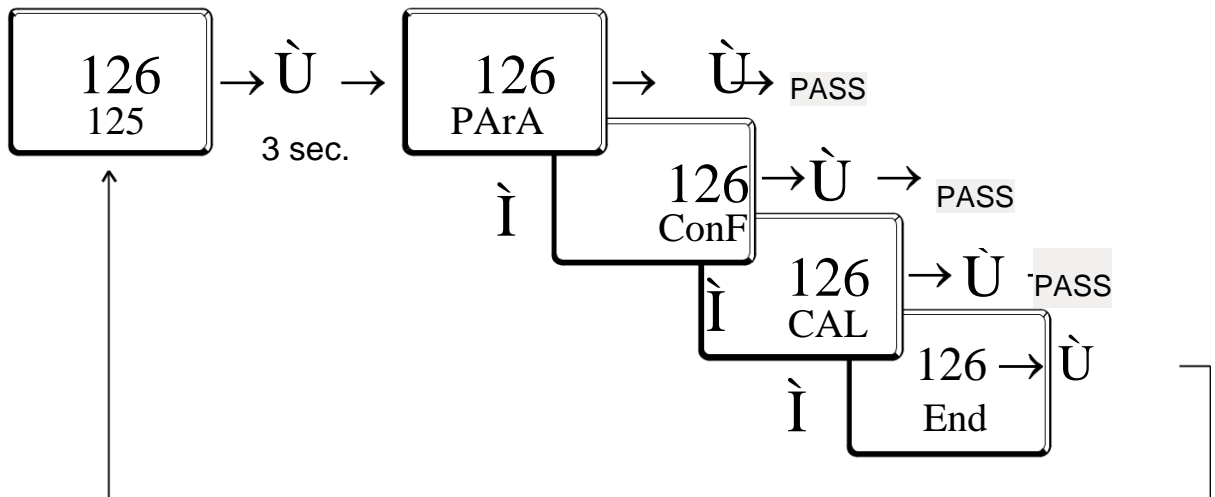

PArA

- level: At PArA - level, the right decimal point of the upper display line is *lit continuously*.



ConF

- level: At ConF - level, the right decimal point of upper display line *blinks*

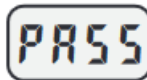

All levels are accessible only by entering the Password (PASS). If the safety switch **Loc** is open all levels are disabled



To get access to the configuration and the parameters the safety switch Loc must be closed (factory setting).

Safety switch Loc	Password entered with BluePort®	Function disabled or enabled with BluePort®	Access via the instrument front panel:
closed	OFF / password	disabled / enabled	enabled
open	OFF / password	disabled	disabled
open	OFF	enabled	enabled
open	Password	enabled	enabled after password entry



Configuration level

4 Configuration level

4.1 Configuration with qUIC

At configuration level, the controller function is determined by changing configuration word Con1 . Con1 and the code adjusted for Con1 are displayed alternately on the lower display line.

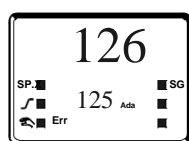

r Ù r PArA

3 sec.

ConF r Ù r qUIC r Ù r Con1 Ì r Ù

123.8 123.8
Con1 152

A B C D

Code signification:

A	0	Reaction at sensor break as process value higher than set-point.
	1	Reaction at sensor break as process value smaller than set-point
	2	Only P30/W connection, always process value smaller than set-point *
B	0	Potentiometric transducer 50-30-50 [/ pressure sensor 0..10V, display range 0,0...100,0 (%)
	1	Potentiometric transducer 50-30-50 [/ pressure sensor 0..10V, display range 0,00...1,00 (bar)
	2	Potentiometric transducer 50-30-50 [/ pressure sensor 0..10V, display range 0,0...16,0 (bar)
	3	Potentiometric transducer 50-30-50 [/ pressure sensor 0..10V, display range 0,0...40,0 (bar)
	4	Resistance thermometer Pt 100 [, range 0...200 °C
	5	Resistance thermometer Pt 100 [, range 0...400 °C
	6	Thermocouple type L, range 0...900 °C
	7	Thermocouple type K, range 0...1350 °C
C	0	Signaller with switching
	1	3-point signaller
	2	3-point stepping controller (DPS) switchable to signaller (SG)
	3	3-point stepping controller (DPS) switchable to 3-point signaller (SG)
D	0	Not changeable

* Only possible with A = 2 and B = 0 ... 3



After exit from the configuration level (see page 43, the controller is re-initialized (all display elements are lit) and changes over to normal operation (operating level).

① Leading zeros are not displayed (ex.: display 400 with code 0400)

Configuration example 1 (code 0400):

KS40-1 as a signaller with switch-over contact for 2-stage burner:
Measuring range 0...200 °C,
Resistance thermometer Pt 100,
Reaction at sensor break
as process value higher than set-point.



Configuration example 2 (code 2120):

KS40-1 as 3-point stepping controller:
Connection to pressure transmitter
P30/W, Measuring range 0,00...1,00 bar,
Reaction at sensor break as process value
smaller than set-point.



Function: Signaller with switch-over contact

CAUTION: The two relays 1 and 2 are coupled, i.e. the contacts have switch-over function. Ensure that the two relays are not energized or de-energized simultaneously. Exception: de-energized condition.

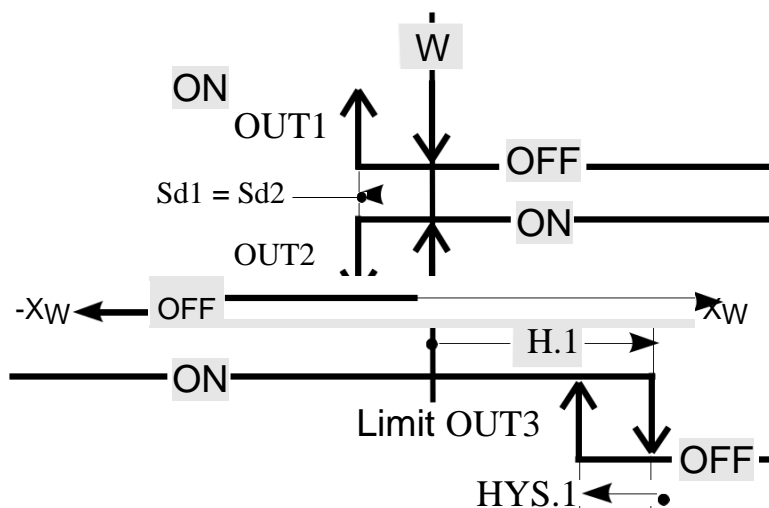

Settings:

Switching differences: Sd1: in physical values
Limit value OUT3: The relay is de-energized when exceeding the limit.
Upper limit value H.1 : in units of phys. quantity.
Switching difference HYS.1 : in units of phys.quantity

Signalling LEDs: LED1: lit when OUT1 is energized
LED2: lit when OUT2 is energized
LED3: lit when OUT3 is energized
OK-LED: lit, unless the limit value is reached

Parameter: see chapter 5 "Parameter level"



Configuration level

Function: 3-point signaller

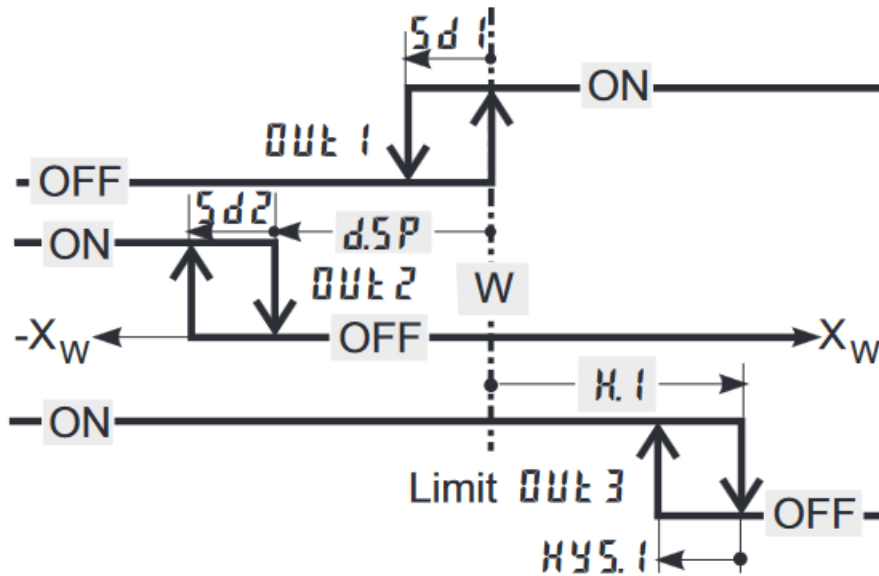

Settings:

OUT 1: Switch-on point is coupled with the set-point.
Switching difference $Sd1$: in units of phys. quantity.

OUT 2: Switch-off point is always below the set-point!
Adjustment range $d.SP$: in units of phys. quantity
Switching difference $Sd2$: in units of phys. quantity.

Limit value OUT 3: With the limit value exceeded, the relay is de-energized.
High limit value $H.L$: in units of phys. quantity.
Switching difference $HYS.1$: in units of phys. quantity.

Signal LEDs: LED1: lit, when **OUT 1** is energized
LED2: lit, when **OUT 2** is energized
OK LED: lit, when limit value not reached

Parameters: see chapter 5 "Parameter level"



4.2 Configuration without qUIC (qUIC= OFF)

When key Û is kept pressed during controller supply voltage switch-on, the configuration is switched off with qUIC.

Now, all configuration settings are available to the user.

For changing back to configuration with qUIC , the two keys ÌÈ must be kept pressed during controller supply voltage switch-on.



Hereby, the controller is reset to the factory-set default values !

4.3 Configuration survey:

Con1

Name	Value range	Description	Default	Own setting
Con1	0000...2330	qUIC - Configuration	0000	

Wire hook switches (on electronic card)

Name	Value range	Description	Default	Own setting
LOC	open or closed	Wire hook switch for locking the ConF - and PAR A - level (if enabled with BlueControl)	closed	
InP.1	mA/Pt or 10V	Wire hook switch for chosing InP.1 signal type	mA/Pt	

Enter

Name	Value range	Description	Default	Own setting
SP.Fn		Basic configuration of setpoint processing	0	
	0	set-point controller can be switched over to external set-point (-> LOGI/ SP.E)		
	1	programmer		
	8	standard controller with external offset (SP.E)		
C.Fnc		Control behavior (algorithm)	0	
	0	2-point signaller		
	1	PID controller (2-point and continuous)		
	2	/ Y/Off, or 2-point controller with partial/full load switch-over		
	3	2 x PID (3-point and continuous)		
	4	3-point stepping controller		
	7	3-point signaller		
	8	3-point stepping controller switchable to signaller		
	9	3-point stepping controller switchable to 3-point signaller		
	mAn		Manual operating permitted	1
0		no		
		yes (see also /)		
C.Act		Method of controller operation	0	
	0	Inverse, e.g. heating		
	1	Direct, e.g. cooling		

**Configuration level**

Name	Value range	Description	Default	Own setting
FAIL		Behavior at sensor break	1	
	0	Controller outputs switched of		
	1	y = Y2		
	2	y= meanoutput. The maximum permissible output can be adjusted with parameter Ym.H. To prevent determination of inadmissible values, mean value formation is only if the control deviation is lower than parameter L.Ym.		
rnG.L	-1999...9999	X0 (low limit range of control) 1	0	
rnG.H	-1999...9999	X100 (high limit range of control) 1	100	

1 rnG.L and rnG.H indicate the control range to which e.g. self-tuning is related.

1 n P. 1

Name	Value range	Description	Default	Own setting
S.tYP		Sensor type selection	50	
	0	Thermocouple type L (-100...900 °C) , Fe-CuNi DIN		
	1	Thermocouple type J (-100...1200 °C) , Fe-CuNi		
	2	Thermocouple type K (-100...1350 °C) , NiCr-Ni		
	3	Thermocouple type N (-100...1300 °C) , Nicrosil-Nisil		
	4	Thermocouple type S (0...1760 °C) , PtRh-Pt10%		
	5	Thermocouple type R (0...1760 °C) , PtRh-Pt13%		
	20	Pt100 (-200,0 ... 100,0 °C)		
	21	Pt100 (-200,0 ... 850,0 °C)		
	22	Pt1000 (-200,0...200,0 °C)		
	23	KTY 11-6 (special 0...4500 Ohm)		
	30	0...20mA / 4...20mA 2		
	40	0...10V / 2...10V 2		
	50	Potentiometer 0...160 Ohm 2		
51	Potentiometer 0...450 Ohm 2			
52	Potentiometer 0...1600 Ohm 2			
S.Lin		Linearization (only at S.tYP = 30 (0..20mA) and 40 (0..10V) adjustable)	0	
	0	None		
	1	Linearization to specification. Creation of linearization table with BlueControl (engineering tool) possible. The characteristic for KTY 11-6 temperature sensors is preset.		
Corr		Measured value correction (scaling	2	
	0	Without scaling		
		Offset correction (at level)		
		2- point correction (at level)		
	3	Scaling (at PArA level)		

2 With current, voltage or potentiometer input signals, scaling is required (see section 5.1).



Configuration level

1 nP.2

Name	Value range	Description	Default	Own setting
I.Fnc		Function selection of INP2	0	
	0	No function		
		External set-point (switching -> /)		
S.tYP		Sensor type selection	30	
	20	Pt100 (-200,0 ... 100,0 °C)		
	21	Pt100 (-200,0 ... 850,0 °C)		
	22	Pt1000 (-200,0...200,0 °C)		
	30	0...20mA / 4...20mA 1		
	50	Potentiometer (0...160 Ohm) 1		
	51	Potentiometer (0...450 Ohm) 1		
	52	Potentiometer (0...1600 Ohm) 1		
Corr		Measured value correction / scaling	0	
	0	Without scaling		
	1	Offset correction (at CALlevel)		
	2	2-point correction (at CALlevel)		
	3	Scaling (at PArA level)		

① With current or potentiometer input signals, scaling is required (see section 5.1).

L ๓

Name	Value range	Description	Default	Own setting
Fnc.1		Function of limit 1 / 2 / 3	1 / 0 / 0	
Fnc.2	0	Switched off		
Fnc.3	1	Measured value monitoring		
	2	Measured value monitoring + alarm status storage. A stored limit value can be reset via error list, O-key or a digital input (-> LOGI/ Err.r)		
Src.1		Source of limit 1 / 2 / 3	1 / 0 / 0	
Src.2	0	Process value = absolut alarm		
Src.3	1	Control deviation Xw (process value - set-point) relativ alarm		
	2	Control deviation Xw (relativ alarm) with suppression after start-up and set-point change		
	6	Effective set-point Weff		
	7	Correcting variable (controller output)		
LP.AL		Monitor ng of control loop interruption	0	
	0	Switched off		
	1	LOOP alarm active		



Out. 1 / 2 / 3

Name	Value range	Description	Default	Own setting
O.Act	Method of operation of output OUT1		Out.1:	0
	0	Direct / normally open	Out.2:	0
	1	Inverse / normaly closed	Out.3:	1
Y.1 Y.2	Controller output Y1 / Y2		Out.1:	1 / 0
	0	Not active	Out.2:	0 / 1
	1	Active	Out.3:	0 / 0
Lim.1 Lim.2 Lim.3	Limit 1 / 2 / 3 signal		Out.1:	0 / 0 / 0
	0	Not active	Out.2:	0 / 0 / 0
	1	Active	Out.3:	1 / 0 / 0
LP.AL	Interruption alarm signal (LOOP)		Out.1:	0
	0	Not active	Out.2:	0
	1	Active	Out.3:	0
FAi.1 FAi.2	INP1 / INP2 error signal		Out.1:	0 / 0
	0	Not active	Out.2:	0 / 0
	1	Active	Out.3:	1 / 0

LOG1

Name	Value range	Description	Default	Own setting
L_r	Local / Remote switching (Remote: adjusting of all values by front keys is blocked)		0	
	0	No function		
	1	Always active		
	3	DI2 switches *		
	4	DI3 switches *		
	5	èkey switches *		
SP.2	Switching to second set-point SP.2		3	
	0	No function		
	3	DI2 switches *		
	4	DI3 switches *		
	5	èkey switches *		
SP.E	Switching to external set-point SP.E		0	
	0	No function		
	1	Always active		
	3	DI2 switches *		
	4	DI3 switches *		
	5	èkey switches *		
Y2	Y/Y2 switching		0	
	0	No function		
	3	DI2 switches *		
	4	DI3 switches *		
	5	èkey switches *		
	6	Ò key switches *		



Configuration level

Name	Value range	Description	Default	Own setting
mAn		Automatic/manual switching	6	
	0	No function		
	1	Always active		
	3	DI2 switches *		
	4	DI3 switches *		
	5	èkey switches *		
	6	Ö key switches *		
C.oFF		Switch of the controller	0	
	0	No function		
	3	DI2 switches *		
	4	DI3 switches *		
	5	èkey switches *		
	6	Ö key switches *		
m.Loc		Blocage of the Ö key	0	
	0	No function		
	3	DI2 switches *		
	4	DI3 switches *		
	5	èkey switches *		
Err.r		Reset of all error list entries	0	
	0	No function		
	3	DI2 switches *		
	4	DI3 switches *		
	5	èkey switches *		
	6	Ö key switches *		
SG		Switching of the controller behavior between 3-point-stepping controller and signaller	4	
	0	No function		
	3	DI2 switches *		
	4	DI3 switches *		
	5	èkey switches *		
P.run		Programmer Run/Stop	5	
	0	No function		
	3	DI2 switches *		
	4	DI3 switches *		
	5	èkey switches *		
di.Fn		Function of digital inputs (valid for all inputs)	0	
	0	Direct		
	1	Inverse		
	2	Toggle key function		

* Multiple switching is possible and should be excluded on demand.



บริษัท เอดีดี เฟอร์เนส จำกัด

ADD FURNACE CO.,LTD.

44 ซอยบรมราชชนนี 70 ถนนบรมราชชนนี แขวงศาลาธรรมสพน์ เขตทวีวัฒนา กรุงเทพฯ 10170

โทร: 02-888-3472 โทร: ออกแบบ:08-08-170-170 แฟกซ์: 02-888-3258

<https://www.add-furnace.com> E-mail: sales@add-furnace.com

Configuration level

other

Name	Value range	Description	Default	Own setting
Unit		Unit	1	
	0	Without unit		
	1	°C		
	2	°F		
dP		Decimal point (max. number of digits behind the decimal point)	0	
	0	No digit behind decimal point		
	1	1 digit behind decimal point		
	2	2 digits behind decimal point		
	3	3 digits behind decimal point		
C.dEI	0...200	Modem delay [ms]	0	



Parameter setting level

5 Parameter setting level

Enter

Visible with qUIC	Name	Value range	Description	Default	Own setting
f	Pb1	1...9999	Proportional band 1 (heating) in phys. dimensions (e.g. °C)	10	
	Pb2	1...9999	Proportional band 2 (cooling) in phys. dimensions (e.g. °C)	10	
f	ti1	1...9999	Integral action time 1 (heating) [s]	10	
	ti2	1...9999	Integral action time 2 (cooling) [s]	10	
f	td1	1...9999	Derivative action time 1 (heating) [s]	10	
	td2	1...9999	Derivative action time 2 (cooling) [s]	10	
	t1	0,4...9999	Minimal cycle duration 1 (heating) [s]. The minimum impulse is 1/4 x t1	10	
	t2	0,4...9999	Minimal cycle duration 2 (heating) [s]. The minimum impulse is 1/4 x t2	10	
f	SH	0...9999	Dead zone or switching differential for on-off control [phys. dimensions]	1	
f	Sd1	0,0...9999	Switching differential relais 1 for signaller with partial/full load switch-over	0,1	
f	Sd2	0,0...9999	Switching differential relais 2 for 3-point signaller	0,1	
f	d.SP	-1999...9999	Trigger point speration for series contact / Y / Off [phys. dimensions]	0	
f	tP	0,1...9999	Minimum impulse [s]	OFF	
f	tt	3...9999	Actuator response time for servo-motor [s]	60	
	Y.Lo	-120...120	Lower output limit [%]	0	
	Y.Hi	-120...120	Upper output limit [%]	100	
	Y2	-120...120	2. correcting variable	0	
	Y.0	-120...120	Working point for the correcting variable [%]	0	
	Ym.H	-120...120	Limitation of the mean value Ym [%]	5	
	L.Ym	0...9999	Max. deviation xw at the start of mean value calculation [phys. dimensions]	8	

SETP

Visible with qUIC	Name	Value range	Description	Default	Own setting
	SP.LO	-1999...9999	Set-point limit low for Weff	0	
	SP.Hi	-1999...9999	Set-point limit high for Weff	100	
f	SP.2	-1999...9999	Set-point 2.	20	
	r.SP	0...9999	Set-point gradient [/min]	OFF	



Parameter setting level

Prog

Visible with qUIC	Name	Value range	Description	Default	Own setting
	SP.01	-1999...9999	Segment end set-point 1	100	
	Pt.01	0...9999	Segment time 1 [min]	10	
	SP.02	-1999...9999	Segment end set-point 2	100	
	Pt.02	0...9999	Segment time 2 [min]	10	
	SP.03	-1999...9999	Segment end set-point 3	200	
	Pt.03	0...9999	Segment time 3 [min]	10	
	SP.04	-1999...9999	Segment end set-point 4	200	
	Pt.04	0...9999	Segment time 4 [min]	10	

InP.1

Visible with qUIC	Name	Value range	Description	Default	Own setting
	InL.1	-1999...9999	Input value for the lower scaling point	38,5	
	OuL.1	-1999...9999	Displayed value for the lower scaling point	0	
	InH.1	-1999...9999	Input value for the upper scaling point	61,5	
	OuH.1	-1999...9999	Displayed value for the lower scaling point	100	
	t.F1	-1999...9999	Filter time constant [s]	0,5	

InP.2

Visible with qUIC	Name	Value range	Description	Default	Own setting
	InL.2	-1999...9999	Input value for the lower scaling point	0	
	OuL.2	-1999...9999	Displayed value for the lower scaling point	0	
	InH.2	-1999...9999	Input value for the upper scaling point	100	
	OuH.2	-1999...9999	Displayed value for the upper scaling point	100	

L 1

Visible with qUIC	Name	Value range	Description	Default	Own setting
	L.1	-1999...9999	Lower limit 1	OFF	
f	H.1	-1999...9999	Upper limit 1	20	
f	HYS.1	0...9999	Hysteresis limit 1	0,1	
	L.2/3	-1999...9999	Lower limit 2 / 3	OFF	
	H.2/3	-1999...9999	Upper limit 2 / 3	OFF	
	HYS.2/3	0...9999	Hysteresis limit 2 / 3	0,1	



Parameter setting level

5.1 Input scaling (only visible with $qUIC = OFF$)

When using current or voltage signals as input variables for $INP.1$ or $INP.2$, scaling of input and display values at parameter setting level is required. Specification of the input value for lower and higher scaling point is in the relevant electrical unit (mA/ V).

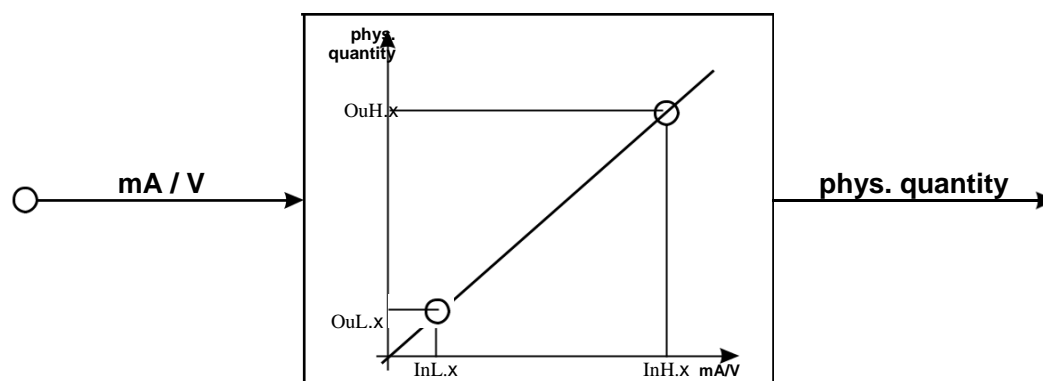

5.1.1 Input $INP.1$

i Parameters $INL.1$, $OUL.1$, $INH.1$ and $OUH.1$ are only visible if $ConF / INP.1 / Corr = 3$ is chosen.

S.tYP	Input signal	INL.1	OUL.1	INH.1	OUH.1
30 (0...20mA)	0 ... 20 mA	0	any	20	any
	4 ... 20 mA	4	any	20	any
40 (0...10V)	0 ... 10 V	0	any	10	any
	2 ... 10 V	2	any	10	any

In addition to these settings, $INL.1$ and $INH.1$ can be adjusted in the range (0...20mA / 0...10V) determined by selection of S.tYP .

! For using the predetermined scaling with thermocouple and resistance thermometer (Pt100), the settings for $INL.1$ and $OUL.1$ and for $INH.1$ and $OUH.1$ must have the same value.

i Input scaling changes at calibration level (r page 27) are displayed by input scaling at parameter setting level. After calibration reset (OFF), the scaling parameters are reset to default.

5.1.2 Input $INP.2$

As input $INP.1$, but only S.Typ = 30 adjustable!



6 Calibration level

i Measured value correction (CAL) is only visible if ConF / InP.1 / Corr = 1 or 2 and qUIC = OFF is chosen.

The measured value can be matched in the calibration menu (CAL). Two methods are available:

Offset correction

(ConF/ InP.1 / Corr =1):

is possible on-line at the process

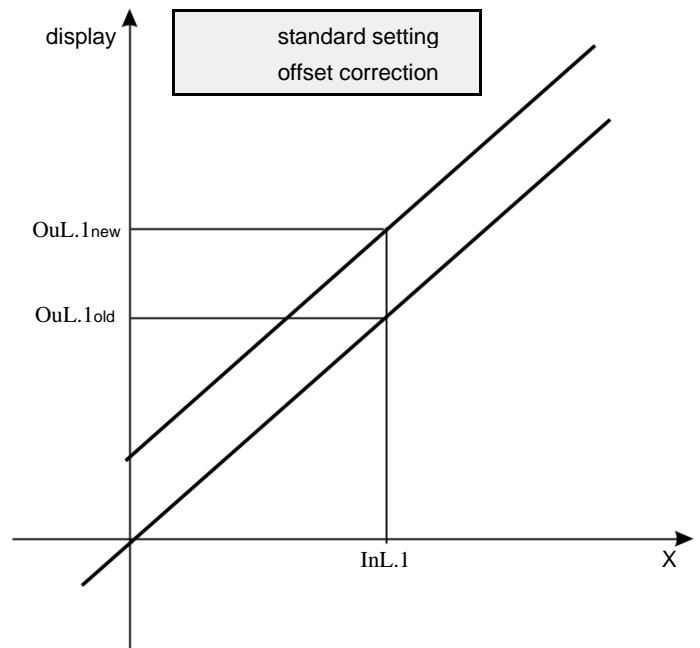

2-point correction

(ConF/ InP.1 / Corr =2):

is possible off-line with process value simulator

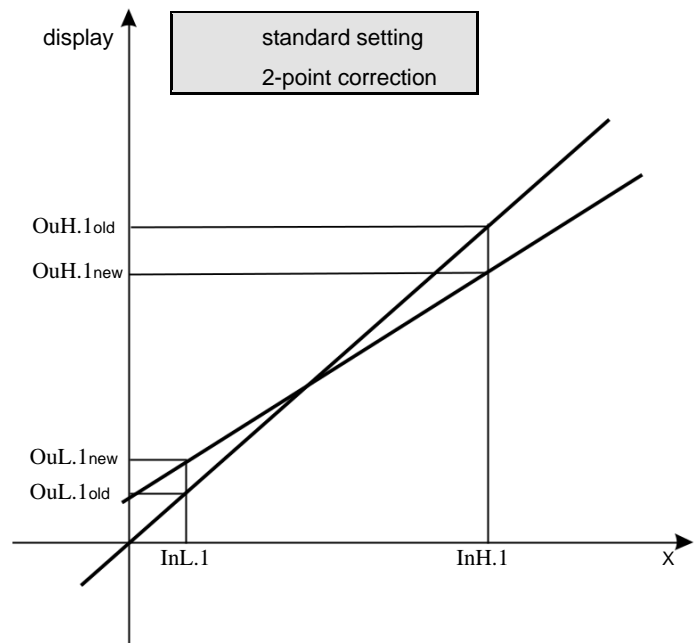



Calibration level

Offset correction ($ConF / InP.1 / Corr = 1$):

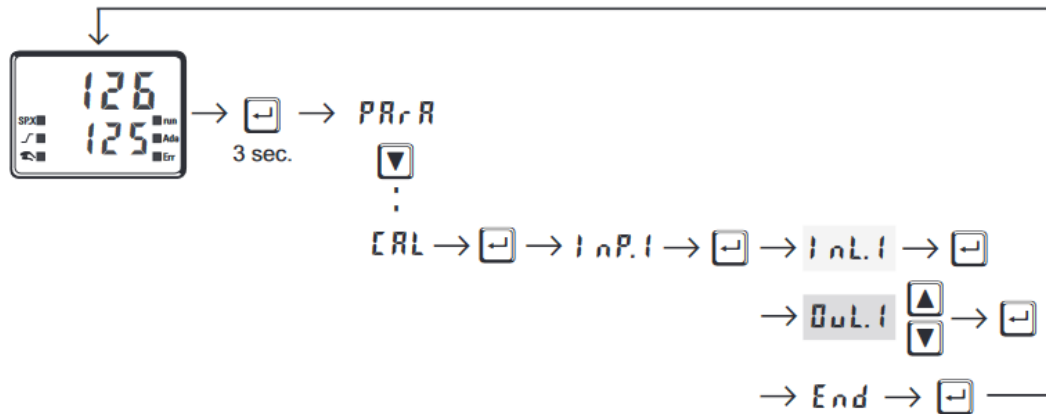

InL.1: The input value of the scaling point is displayed.

The operator must wait, until the process is at rest.

Subsequently, the operator acknowledges the input value by pressing key Û.

OuL.1: The display value of the scaling point is displayed.

Before calibration, OuL.1 is equal to InL.1.

The operator can correct the display value by pressing keys ÈÌ.
Subsequently, he confirms the display value by pressing key Û.



Calibration level

2-point correction (ConF / InP.1 / Corr = 1):

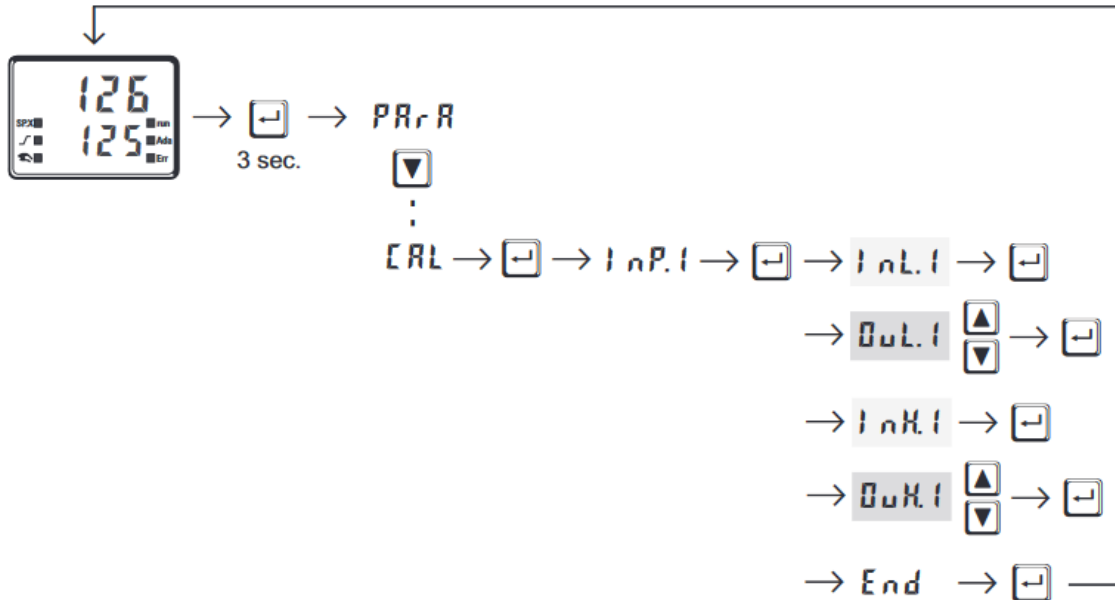

- InL.1:** The input value of the lower scaling point is displayed.
The operator must adjust the lower input value by means of a process value simulator and confirm the input value by pressing key Û.
- OuL.1:** The display value of the lower scaling point is displayed.
Before calibration, OuL.1 equals InL.1.
The operator can correct the lower display value by pressing the ÈÌ keys. Subsequently, he confirms the display value by pressing key Û.
- InH.1:** The input value of the upper scaling point is displayed. .
The operator must adjust the upper input value by means of the process value simulator and confirm the input value by pressing key Û.
- OuH.1:** The display value of the upper scaling point is displayed.
Before calibration OuH.1 equals InH.1.
The operator can correct the upper display value by pressing keys ÈÌ. Subsequently, he confirms the display value by pressing key Û.



The parameters (OuL.1, OuH.1) changed at CAL level can be reset by adjusting the parameters below the lowest adjustment value (OFF) by means of decrement key Ì.



Programmer

7 Programmer

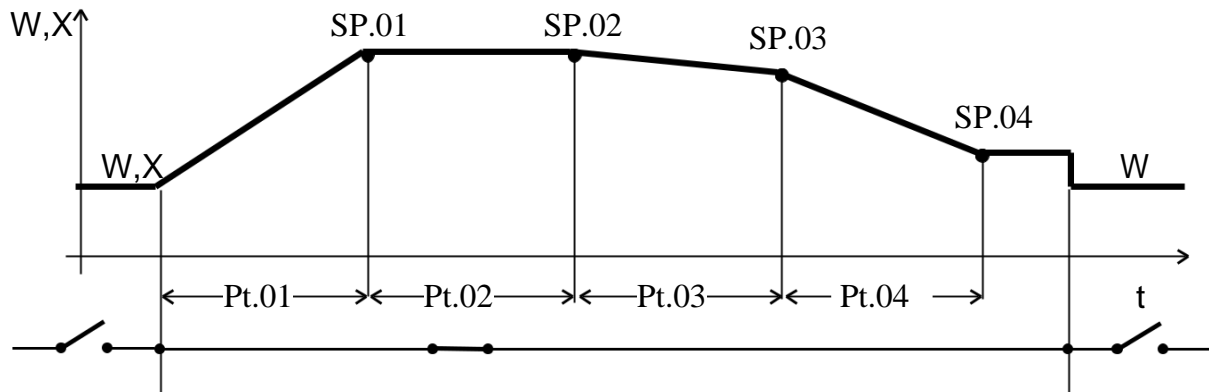

Programmer set-up:

For using the controller as a programmer, select parameter $SP.Fn = 1$ in the ConF menu. The programmer is started via one of digital inputs $di2..3$ or the \grave{e} key. Which input shall be used for starting the programmer is determined by selecting parameter $P.run = 3 / 4 / 5$ in the ConF menu accordingly.

For assigning the program end as a digital signal to one of the relay outputs, parameter $P.End = 1$ must be selected for the relevant output $OUT.1...OUT.3$ in the ConF menu.

Programmer parameter setting:

A programmer with 4 segments is available to the user. Determine a segment duration $Pt.01 .. Pt.04$ (in minutes) and a segment target set-point $SP.01 .. SP.04$ for each segment in the PArA menu.

Starting/stopping the programmer:

Starting the programmer is done by a digital signal at input $di2..3$ or by pressing the \grave{e} key selected by parameter $P.run$.

The programmer calculates a gradient from segment end setpoint and segment time. This gradient is always valid. Normally, the programmer starts the first segment at process value. Because of this the effective run-time of the first segment may differ from the at PArA level setted segment time (process value set-point).

After program end, the controller continues controlling with the target set-point set last.

If the program is stopped during execution (signal at digital input $di2..3$ or the \grave{e} key is taken away), the programmer returns to program start and waits for a new start signal.



Program parameter changing while the program is running is possible.

Changing the segment time:

Changing the segment time leads to re-calculation of the required gradient. When the segment time has already elapsed, starting with the new segment is done directly, where the set-point changes with a step.

Changing the segment end setpoint:

Changing the set-point leads to re-calculation of the required gradient, in order to reach the new set-point during the segment rest time, whereby the required gradient polarity sign can change.



8 Technical data

INPUTS

PROCESS VALUE INPUT INP1

Resolution: > 14 bits
 Decimal point: 0 to 3 digits behind the decimal point
 Dig. input filter: adjustable 0,000...9999 s
 Scanning cycle: 100 ms
 Measured value correction: 2-point or offset correction

Thermocouples

r Table 2 (page 58)

Input resistance: 1 M
 Effect of source resistance: 1 V/

Cold-junction compensation

Maximal additional error: 0,5 K

Sensor break monitoring

Sensor current: 1 A
 Configurable output action

Resistance thermometer

r Table 2 (page 58)

Connection: 2 or 3-wire
 Lead resistance: max. 30 Ohm
 Input circuit monitor: break and short circuit

Potentiometric transducer 50-30-50

Current and voltage

signals r Table 3 (page 58)

Span start, end of span: anywhere within measuring range

Scaling: selectable -1999...9999
 Linearization: 16 segments, adaptable with BlueControl

Decimal point: adjustable
 Input circuit monitor: 12,5% below span start

(2mA, 1V)

SUPPLEMENTARY INPUT INP2

Resolution: > 14 bits
 Scanning cycle: 100 ms
 Accuracy: < 0,5 %

Current measuring range

Technical data as for INP1

Potentiometer

r Table 2 (page 58)

Connection: 3-wire
 Lead resistance: max. 30 Ohm
 Input circuit monitor: break

CONTROL INPUT DI2/DI3

Configurable as switch or push-button!

Connection of a potential-free contact suitable for switching "dry" circuits.

Switched voltage: 5 V
 Current: 160 A

TRANSMITTER SUPPLY U_T (OPTION)

Power: 22 mA / 18 V

GALVANIC ISOLATION

— Safety isolation
 === Function isolation

Power supply connections	Process value input INP1 Supplementary input INP2 Digital inputs di2, 3 Transmitter supply U_T
Relay outputs OUT 1,2	
Relay output OUT3	



บริษัท เอดีดี เฟอร์เนส จำกัด

ADD FURNACE CO.,LTD.

44 ซอยบรมราชชนนี 70 ถนนบรมราชชนนี แขวงศาลาธรรมสพน์ เขตทวีวัฒนา กรุงเทพฯ 10170

โทร: 02-888-3472 โทร: ออกแบบ:08-08-170-170 แฟกซ์: 02-888-3258

<https://www.add-furnace.com> E-mail: sales@add-furnace.com

OUTPUTS

RELAY OUTPUTS OUT1, OUT2

Contact type: 2 NO contacts with
common connection

Max. contact rating: 500 VA, 250 V, 2A at
48...62 Hz,
resistive load

Min. contact rating: 6V, 1 mA DC

Operating life (electr.): 800.000 duty cycles with
max. rating

RELAY OUTPUT OUT3

Contact type: potential-free changeover
contact

Max. contact rating: 500 VA, 250 V, 2A at 48...62
Hz,
resistive load

Min. contact rating: 5V, 10 mA AC/DC

Operating life (electr.): 600.000 duty cycles
with
max. contact rating

Note:

If the relays OUT1...OUT3 operate external
contactors, these must be fitted with RC
snubber circuits to manufacturer specifications
to prevent excessive switch-off voltage peaks.

POWER SUPPLY

AC SUPPLY

Voltage: 90...250 V AC

Frequency: 48...62 Hz

Power consumption approx. 7,3 VA

BEHAVIOUR WITH POWER FAILURE

*Configuration, parameters and adjusted
set-points, control mode:*

Non-volatile storage in EEPROM

ENVIRONMENTAL CONDITIONS

Protection modes

Front panel: IP 65 (NEMA 4X)

Housing: IP 20

Terminals: IP 00

Permissible temperatures

For specified accuracy: 0...60°C

Warm-up time: ε 15 minutes

For operation: -20...65°C

For storage: -40...70°C

Humidity

75% yearly average, no condensation

Altitude

To 2000 m above sea level

Shock and vibration

Vibration test Fc (DIN 68-2-6)

Frequency: 10...150 Hz

Unit in operation: 1g or 0,075 mm

Unit not in operation: 2g or 0,15 mm

Shock test Ea (DIN IEC 68-2-27)

Shock: 15g

Duration: 11ms

Electromagnetic compatibility

Complies with EN 61 326-1
(for continuous, non-attended operation)



GENERAL

Housing

Material: Makrolon 9415
flame-retardant
Flammability class:UL 94 VO, self-extinguishing
Plug-in module, inserted from the front

Safety test

Complies with EN 61010-1 (VDE 0411-1):
Overvoltage category II
Contamination class 2
Working voltage range 300 V
Protection class II

Certifications

Type tested to EN 14597 (replaces DIN 3440)

With certified sensors applicable for:

- w Heat generating plants with outflow temperatures up to 120°C to DIN 4751
- w Hot-water plants with outflow temperatures above 110°C to DIN 4752
- w Thermal transfer plants with organic transfer media to DIN 4754
- w Oil-heated plants to DIN 4755

cULus-certification

(Type 1, indoor use)
File: E 208286

Electrical connections

Flat-pin connectors 1 x 6,3 mm or 2 x 2,8 mm to DIN 46 244

Mounting

Panel mounting with two fixing clamps at top/bottom or right/left,
High-density mounting possible

Mounting position: uncritical
Weight: 0,27kg

Accessories delivered with the unit

Operating manual
Fixing clamps

**Technical data***Table 1 Thermocouples measuring ranges*

Type		Range		Accuracy	Resolution (°)
L	Fe-CuNi (DIN)	-100... 900 °C	-148...1652 °F	±2K	0,1 K
J	Fe-CuNi	-100... 1200 °C	-148...2192 °F	±2K	0,1 K
K	NiCr-Ni	-100... 1350 °C	-148...2462 °F	±2K	0,2 K
N	Nicrosil/Nisil	-100... 1300 °C	-148...2372 °F	±2K	0,2 K
S	PtRh-Pt 10%	0... 1760 °C	32... 3200 °F	±2K	0,2 K
R	PtRh-Pt 13%	0... 1760 °C	32... 3200 °F	±2K	0,2 K
T	Cu-CuNi	-200... 400 °C	-328...752 °F	±2K	0,05 K
C	W5%Re-W26%Re	0... 2315 °C	32... 4199 °F	±2K	0,4 K
D	W3%Re-W25%Re	0... 2315 °C	32... 4199 °F	±2K	0,4 K
E	NiCr-CuNi	-100... 1000 °C	-148...1832 °F	±2K	0,1 K
B *	PtRh-Pt6%	0(100)... 1820 °C	32(212) 3308 °F...	±2K	0,3 K

* Specifications valid for 100°C

Table 2 Resistance transducer measuring ranges

Type	Sensor current	Range		Accuracy	Resolution (°)
Pt100	0,2 mA	-200...100 °C	-140...212 °F	±1K	0,1K
Pt100		-200...850 °C	-140...1562 °F	±1K	0,1K
Pt1000		-200...200 °C	-140...392 °F	±2K	0,1K
KTY 11-6 *		-50...150 °C	-58...302 °F	±2K	0,05K
Spezial		0...4500		±0,1 %	0,01 %
Spezial		0...450			
Poti		0...160			
Poti		0...450			
Poti		0...1600			

* Or special

Table 3 Current and voltage measuring ranges

Range	Input resistance	Accuracy	Resolution (°)
0-10 Volt	~ 110 k	±0,1 %	±0,6 mV
0-20 mA	49 (voltage requirement ±2,5 V)	±0,1 %	±1,5 A



Safety hints

9 Safety hints

This unit was built and tested in compliance with VDE 0411-1 / EN 61010-1 and was delivered in safe condition.

The unit complies with European guideline 89/336/EWG (EMC) and is provided with CE marking.

The unit was tested before delivery and has passed the tests required by the test schedule. To maintain this condition and to ensure safe operation, the user must follow the hints and warnings given in this operating manual.

The unit is intended exclusively for use as a measurement and control instrument in technical installations.



Warning

If the unit is damaged to an extent that safe operation seems impossible, the unit must not be taken into operation.

ELECTRICAL CONNECTIONS

The electrical wiring must conform to local standards (e.g. VDE 0100). The input measurement and control leads must be kept separate from signal and power supply leads.

COMMISSIONING

Before instrument switch-on, check that the following information is taken into account:

- Ensure that the supply voltage corresponds to the specifications on the type label.
- All covers required for contact protection must be fitted.
- If the controller is connected with other units in the same signal loop, check

that the equipment in the output circuit is not affected before switch-on. If necessary, suitable protective measures must be taken.

- The unit may be operated only in installed condition.
- Before and during operation, the temperature restrictions specified for controller operation must be met.

SHUT-DOWN

For taking the unit out of operation, disconnect it from all voltage sources and protect it against accidental operation.

If the controller is connected with other equipment in the same signal loop, check that other equipment in the output circuit is not affected before switch-off.

If necessary, suitable protective measures must be taken.



MAINTENANCE, REPAIR AND MODIFICATION

The units do not need particular maintenance.



Warning

When opening the units, or when removing covers or components, live parts and terminals may be exposed.

Before starting this work, the unit must be disconnected completely.

After completing this work, re-shut the unit and re-fit all covers and components. Check if specifications on the type label must be changed and correct them, if necessary.



Caution

When opening the units, components which are sensitive to electrostatic discharge (ESD) can be exposed. The following work may be done only at workstations with suitable ESD protection.

Modification, maintenance and repair work may be done only by trained and authorized personnel. For this purpose, the PMA service should be contacted.



Safety hints

9.1 Resetting to factory setting

In case of faulty configuration, KS4x-1 can be reset to the default condition.

For this, the operator must keep the keys increment and decrement pressed during power-on.



Then, press key increment to select YES.

Confirm factory resetting with Enter and the copy procedure is started (display COPY).

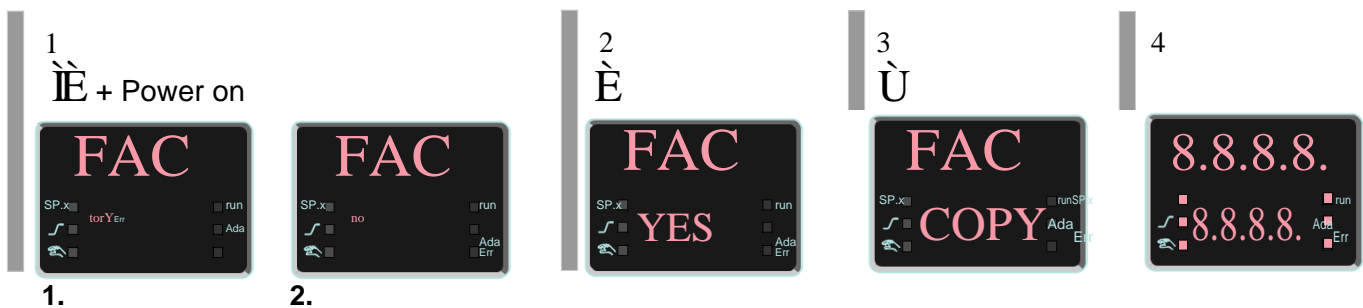
Afterwards the device restarts.



In all other cases, no reset will occur (timeout abortion).

-  If one of the operating levels was blocked and the safety lock is open, reset to factory setting is not possible.
-  If a pass number was defined (via BlueControl[®]) and the safety lock is open, but no operating level was blocked, enter the correct pass number when prompted in 3. A wrong pass number aborts the reset action.
-  The copy procedure (COPY) can take some seconds. Now, the transmitter is in normal operation.



Index

0-9

2-point correction 27

C

Calibration (CAL) 27

Calibration level (CAL) 27 - 29

Configuration with QUIC 14 - 17

Configuration without QUIC 18

Control inputs di1, di2, di3

 Technical data 32

Current signal measuring range 32

D

Digital inputs di1, di2, di3

 Technical data 32

E

Error list 9 Example

 3-point signaller 16

 3-point stepping controller 17

 Signaller with switch-over contact ... 15

F

 Front view 7

I

Input INP1

 Parameters 25

 Technical data 32

Input INP2

 Parameters 25

 Input scaling 26

L

LED

 Ada - LED 7

 Err - LED 7

 ì - LED 7

 ò - LED 7

 run - LED 7

 SP.x - LED 7

M

Maintenance manager 9

Manual tuning 11 - 12

Mounting 5

O

Offset correction 27

Output OUT1

 Technical data 33

Output OUT2

 Technical data 33

P

Programmer

 Changing segment end setpoint 31

 Changing segment time 31

 Parameter setting 30 Set-up

 30 Starting/Stopping

 30

Q

QUIC Codes 14

R

Resetting to factory setting. 38

Resistance thermometer measuring range . 32

S

Safety hints 36 - 38

Safety switch 5

Safety test 34

Self-tuning

 Cancellation 10 - 11

 Cancellation causes 11

 Start 10

T

Thermocouple measuring range 32

V

Voltage signal measuring range 32



บริษัท เอดีดี เฟอร์เนส จำกัด

ADD FURNACE CO.,LTD.

44 ซอยบรมราชชนนี 70 ถนนบรมราชชนนี แขวงศาลาธรรมสพน์ เขตทวีวัฒนา กรุงเทพฯ 10170

โทร: 02-888-3472 โทร: ออกแบบ:08-08-170-170 แฟกซ์: 02-888-3258

<https://www.add-furnace.com> E-mail: sales@add-furnace.com



9499- 040- 66011

Subject to alterations without notice
Anderungen vorbehalten
Sous r serve de toutes modifications

  PMA Proze- und Maschinen-Automation GmbH
P.O.B. 310 229, D-34058 Kassel, Germany
Printed in Germany 9499-040-66011 (08/2013)

A6

A5 auf A6 gefaltet, 2-fach geheftet, SW-Druck Normalpapier wei 80g/m2