



Product Catalogue

Flame Monitoring Systems and Accessories

Sensors and Systems for Combustion Engineering

Table of Contents

■ Flame Scanner Selection Criteria.	5
■ Selection Criteria - Flame Scanner/ Flame Sensor	5
■ Selection Criteria according to Wavelength	5
■ Flame Monitoring Device F130I.	6
■ Flame Monitoring Device F152.	7
■ Flame Sensor FFS07 and FFS07 Ex-II/Ex (Ex-Zone 2 and 1).	8
■ Flame Sensor FFS08.	11
■ Flame Monitoring System F350 + FFS30 Ex-II/Ex (Ex-Zone 2 and 1).	13
■ Compact Flame Scanner F200K / F200K Ex-II (Ex-Zone 2).	15
■ Compact Flame Scanner F200K (Ex-Zone 1).	17
■ Compact Flame Scanner F300K (Ex Zone 2).	19
■ External User Interface FB30-00/10 for F300K and F350.	21
■ Commissioning Case in Combination with F300K.	23
■ Comparison Table Flame Scanner/Sensor	26
■ Brackets	27
■ General Information about the Brackets.	28
■ Brackets and Accessories for FFS07	29
■ Brackets and Accessories for FFS08	30
■ Brackets and Accessories for FFS30	31
■ Brackets and Accessories for F200K	32
■ Brackets and Accessories for F300K	33
■ Assignment of Brackets to Flame Scanners.	34
■ Brackets for FFS07	34
■ Brackets for FFS08	34
■ Brackets for FFS30	34
■ Brackets for F200K	35
■ Brackets for F300K	35

■ Threaded Connection FV30-00 and FV30-01 (stainless steel).	38
■ Threaded Connection with Purge Air connection FV30-10 and FV30-11 (stainless steel).	39
■ Threaded Connection with Purge Air Connection FV30-15 excess Pressure.	40
■ Threaded Connection with Purge Air Coupling and Globe Joint FV40-10 and FV40-11.	41
■ Threaded Connection with Purge Air Coupling and Globe Joint FV40-15 excess Pressure.	42
■ Plug-in Bracket FH30-00.	43
■ Plug-in Bracket with Purge Air Coupling FH30-10.	44
■ Plug-in Bracket with Purge Air Coupling and Globe Joint FH40-10.	45
■ Bracket FS60-00.	46
■ Bracket with adjusting Ring FS60-10.	47
■ Adjustment Bracket FH80-00.	48
■ Adjustment Bracket with Globe Joint FH80-10.	49
■ Bracket with 90° deflecting Mirror FR20-01 as plug-in and threaded Connection Variant.	50
■ Cooling Air Housing	51
■ Cooling air Housing FS30.	52
■ Cooling air Housing and Globe Joint FS41.	53
■ Cooling air Housing with Bracket detachable and adjustable FS36.	54
■ Cooling air Housing FS65.	55
■ Performance characteristic Cooling air housing FS65	55
■ Cooling air Housing FS50.	56
■ Performance characteristic Cooling air housing FS50	57
■ Cooling air Housing with Globe Joint FS51.	58
■ Cooling air Housing with Bracket detachable and adjustable FS56.	59
■ Cooling air Housing FK30.	60
■ Performance characteristic Cooling air Housing FK30	61
■ Cooling air Housing with Purge Air Coupling and Globe Joint FK41	62
■ Cooling air Housing with Purge Air Coupling and FS35 - FK46.	63

■ Globe Joint FS10 and FS11 (stainless steel).	64
■ Welding Neck Flange FS1x in V4A and V2A.	65
■ Insulation Part for Flame Scanner Brackets.	66
■ Vibration Decoupler.	67
■ Shut-off Unit.	68
■ Ionisation Terminal.	69
■ Protective Tube for Cables.	70
■ Heated Thermal Jacket for F200K.	71
■ Weather Protection for F200K and F200K-Ex.	72
■ Flame-Scanner Testing Device FFP30.	73
■ Power Supplies for Flame Scanners.	74
■ Junction Box for Flame Scanner FFS07, FFS08, F200K, F300K.	75
■ Flamescanner Remote Software.	76
■ Optics Holders and Lenses for Flame Sensors.	78
■ Spare Parts.	79
■ Discontinued item.	80
■ Discontinued item.	81
■ Discontinued item.	82

Flame Scanner Selection Criteria.

Selection Criteria - Flame Scanner/ Flame Sensor

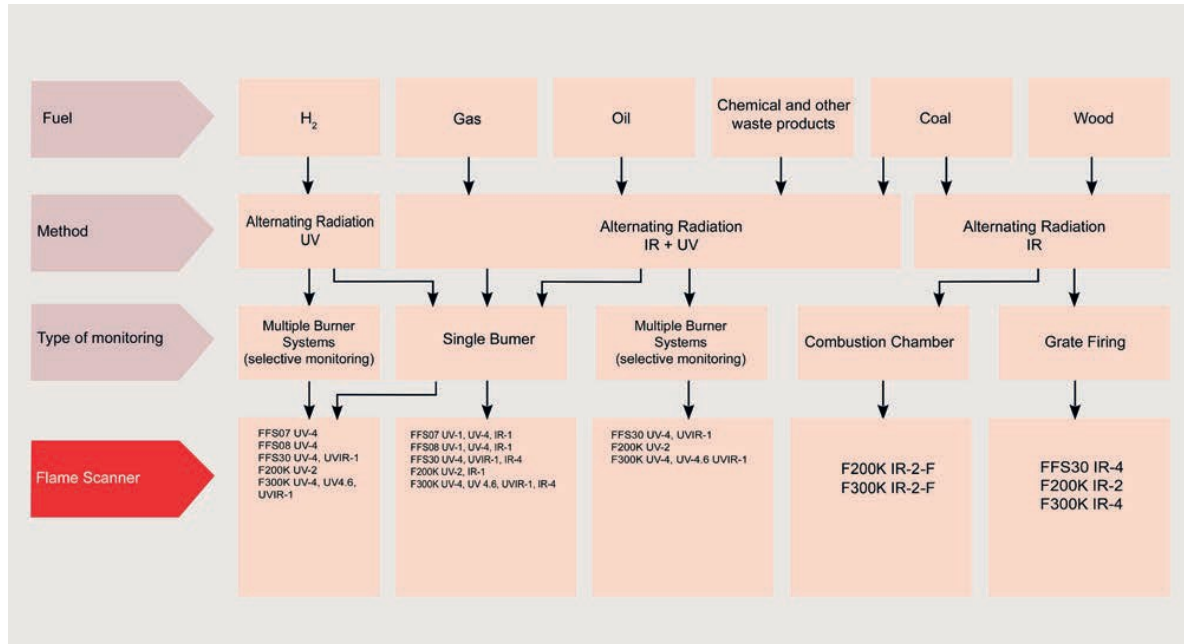

Selection Criteria according to Wavelength

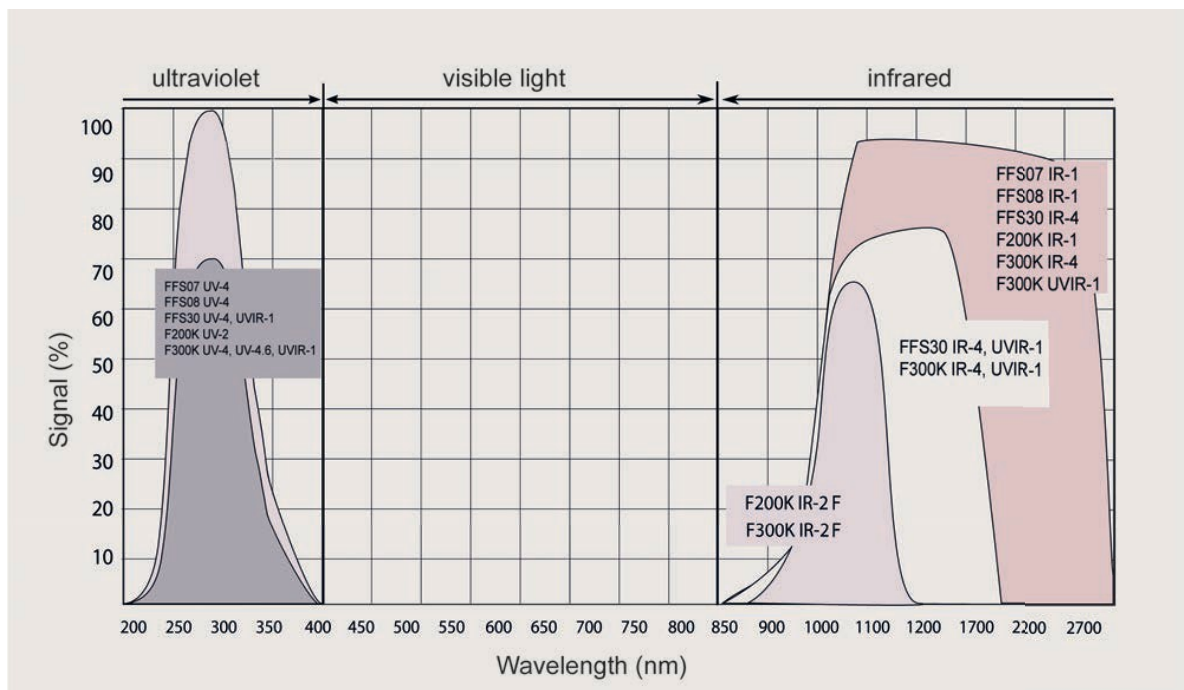

Flame Monitoring Device F130I.

Technical data



Flame monitoring device F130I

Item number	659G1001 (230 VAC) 659G1002 (120 VAC)	Dimensions [mm]	See dimensional drawings
Application	Monitoring of flames (ignition or main flame) using the ionisation method.	Material	Plastic
Power supply voltage	230 VAC +10% -15% or 120 VAC +10% -20%	Weight [kg]	0.5
Power consumption	≤ 10 VA	Protection class	IP20
Output contact status signal	Not safety-oriented, potential-free contact	Ambient temperature	- 20 ... + 60 °C
Flame signal output contact	Safety-oriented floating contact	Approval	UL, CE, SIL 3, UKCA
FFDT (Flame failure detection time)	230 V 1 s 120 V 3 s		

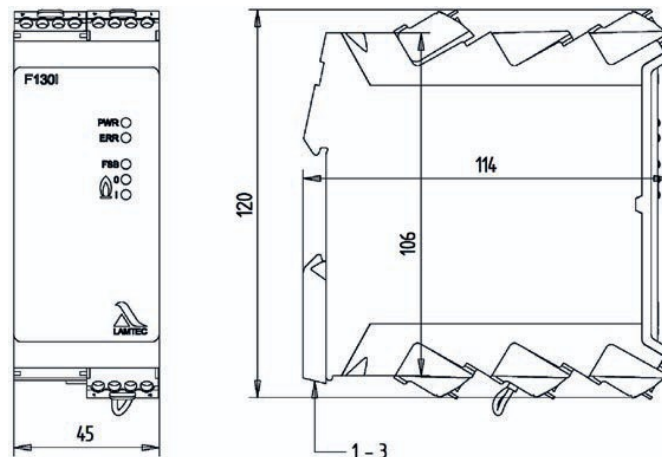

Dimensional Drawing F130I

Flame Monitoring Device F152.

Technical data



Flame monitoring device F152

Item number	659G0501 (230 VAC) 659G0502 (120 VAC) 659G0504 (120 VAC 3 s)	Dimensions [mm]	See dimensional drawings
Application	Monitoring of single burner systems	Material	Plastic
Power supply voltage	230 VAC +10 % -15 % 115 VAC +10 % -15 %, at the factory	Weight [kg]	0.5
Power consumption	≤ 5 VA	Protection class	IP20
Output contact status signal	Switch NC (floating changeover switch)	Ambient temperature	- 10 ... + 60 °C
Flame signal output contact	Switch NO (floating changeover switch)	Approval	UL, CE, SIL 3, UKCA

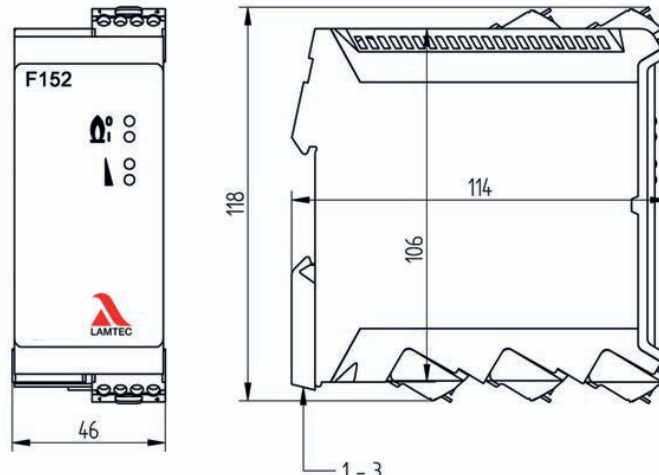

Dimensional Drawing F152

Flame Sensor FFS07 and FFS07 Ex-II/Ex (Ex-Zone 2 and 1).

Technical data



FFS07



FFS07 V



FFS07 Ex

Item number	659D21 ..	Cable lengths	<300 m
Application	Monitoring of single burner systems	Dimensions [mm]	See dimensional drawings
Power supply voltage	24...42 VDC via evaluation device	Material	Corrosion-resistant aluminium EN AW 6082 (seawater 2*; weather 1*) FFS07 EX: EN CW614N (brass) nickel plated
Operation	only in combination with F152/ CMS /ETAMATIC/ETAMATIC OEM/ MCG-BC400	Weight [kg]	0.45 FFS07/FFS07 V 0.5 FFS07 EX
Sensor type	UV-1, UV-4, IR- 1, IR-1 T	Protection class	IP66 Ex Zone 1 IP67 Ex Zone 2
Ex Zone 1	II 2G Ex d IIC T6 Gb	Operating temperature	UV: -20 °C ... + 65 °C IR: -20 °C ... + 60 °C
Ex Zone 2	II 2D Ex tb IIIC T80°C Db II 3G Ex nA IIC T5 (T6) Gc X II 3D Ex tc IIIC T95°C Dc X		
Suitable Brackets:	For plug-in variant: FH For threaded connection variant: FV For Ex Zone I: FV		

* Comparative evaluation from 1 (very good) to 6 (not suitable)

Flame Sensor FFS07 and FFS07 Ex-II/Ex (Ex-Zone 2 and 1)

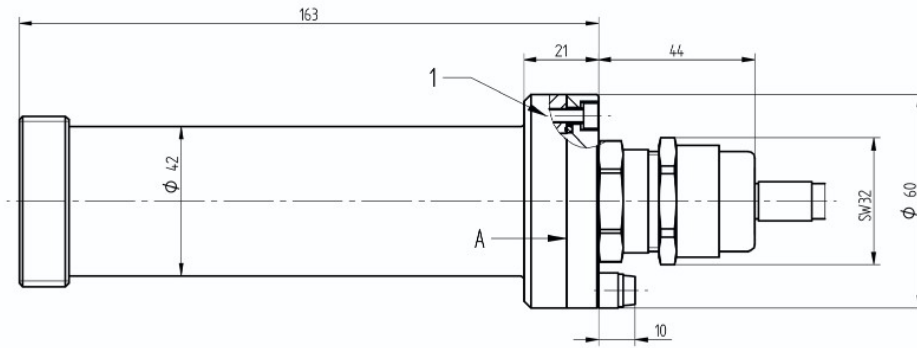

Dimensional Drawing FFS07 EX

Flame Sensor FFS08.

Technical data



FFS08 long version

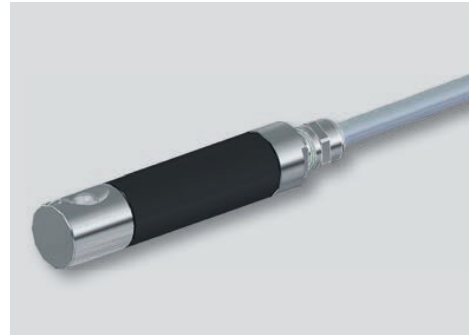

FFS08 short version

Item number	659D31...	Dimensions [mm]	See dimensional drawings
Application	Monitoring of single burner systems	Material	EN CW614N (brass) nickel plated, partly black, powder-coated
Power supply voltage	24...42 VDC via evaluation device	Weight [kg]	0.40 short design 0.55 long design
Operation	only in combination with F152/ CMS /ETAMATIC/ETAMATIC OEM/ MCC-BC400	Protection class	IP67
Sensor type	UV-1, UV-4, IR-1, IR-1T, IR-1T/S2	Operating temperature	UV: -20 °C ... +65 °C IR: -20 °C ... +60 °C
Cable lengths	<300 m	Suitable Brackets	FH 80 FS 60
Ex Zone	No Ex Zone application		

Flame Sensor FFS08

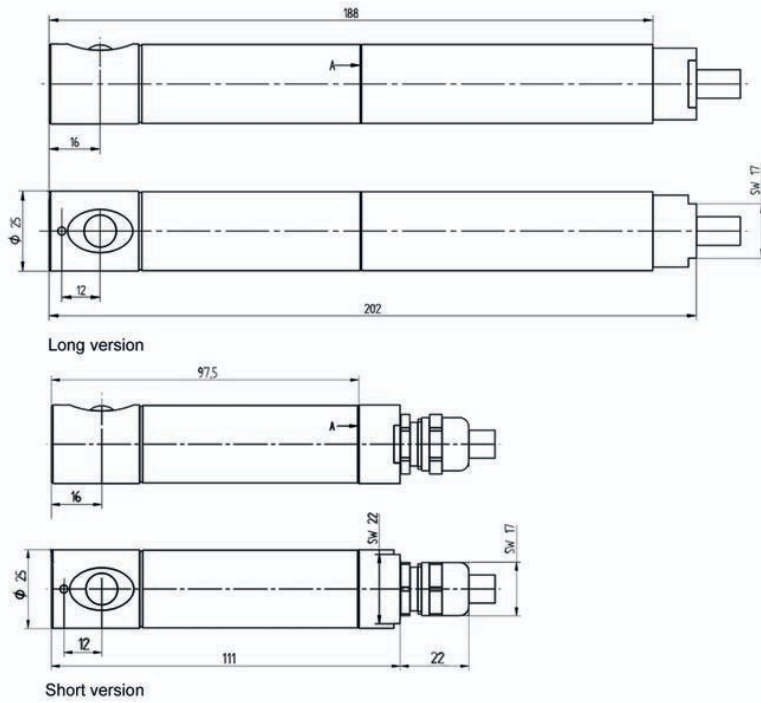

Dimensional Drawing FFS08

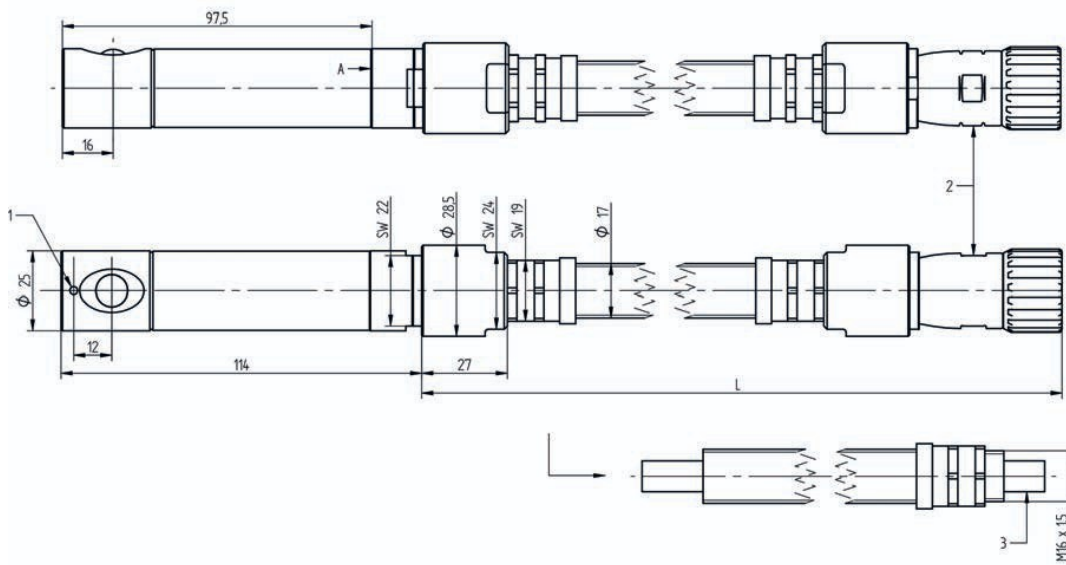

Dimensional drawing FFS08 with metal protection hose, FFS08 with extended housing comparable

Flame Monitoring System F350 + FFS30 Ex-II/Ex (Ex-Zone 2 and 1).

Technical data



Flame monitoring system F350 + FFS30

Item number	F350: 659G5000 FFS30: 659D50..	Dimensions [mm]	See dimensional drawings
Application	Monitoring of single burner and multi-burner combustion systems	Material	FFS30 (aluminium) nickel plated F350 Plastic
Power supply voltage	F350 24 VDC $\pm 20\%$ (SELV/PELV) FFS30 12 VDC	Weight [kg]	0.30 F350 0.30 FFS30 0.90 FFS30 Ex
Operating mode	Continuous operation	Protection class	FFS30: IP67 FFS30 Ex: IP66/67 F350: IP20
Sensor type	UV-4 (ExI, ExII), UVIR-1 (Ex I, Ex II), IR-2 (non Ex), IR-4	Operating temperature	-40 °C ... + 85 °C
Cable lengths	max 80 m	Suitable Brackets	FV30 ... FV40 ...
Ex Zone 1 Ex Zone 2	II 2G Ex d IIC T6 Gb II 2D Ex tb IIIC T80°C Db II 3G Ex nA IIC T5 (T6) Gc X II 3D Ex tc IIIC T95°C Dc X	Approval	F350: SIL 3 UL, CE, UKCA in preparation

Flame Monitoring System F350 + FFS30

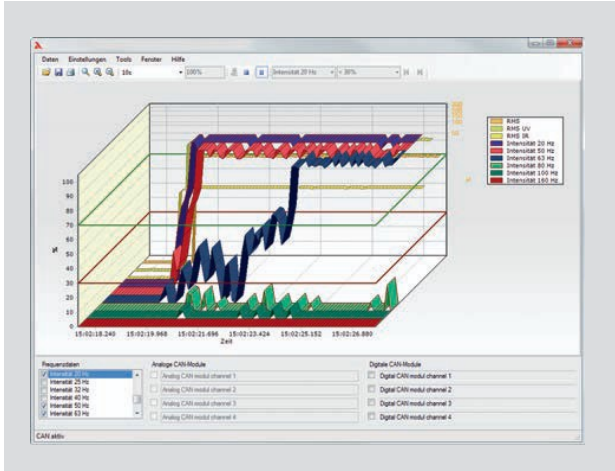

Flamescanner Remote Software (FRS)

- Connection to the PC via FSB/USB module and adapter cables.
- The flamescanner remote software allows you to set all parameters. In addition, it also offers analysis, data backup and recording functions.
- In addition to the flame scanner data, you can also connect up and record external, analogue and/or digital data by means of FSB modules. All of the data is synchronised.

Flamescanner Remote Software item number 659R9000

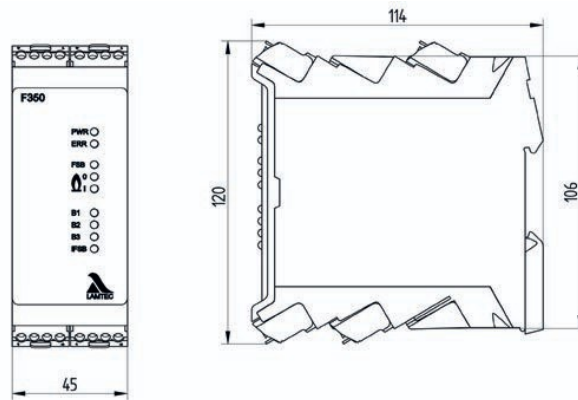

Dimensional drawing F350

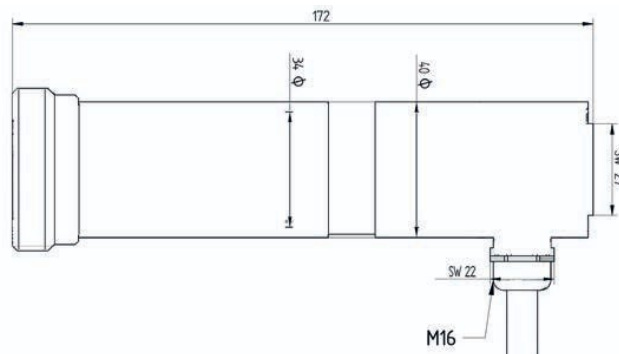

Dimensional drawing FFS30 Standard + Ex Zone 2

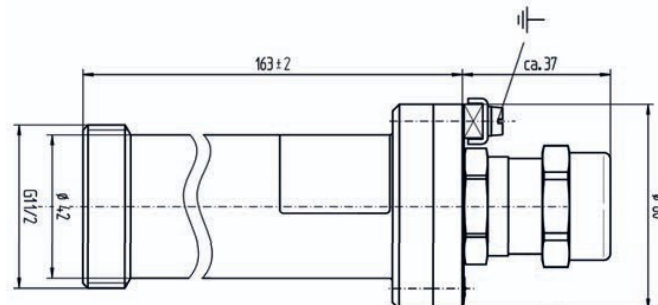

Dimensional drawing FFS30-Ex housing

Compact Flame Scanner F200K / F200K Ex-II (Ex-Zone 2).

Technical data



Compact flame scanner F200K and F200K EX-Zone 2



Compact flame scanner F200K and F200K Ex-Zone 2 threaded connection version

Item number	659R60 ...	Dimensions [mm]	L=180 Ø=40/80
Application	Monitoring of single burner and multi-burner combustion systems	Material	Corrosion-resistant aluminium EN AW 6082 (seawater 2*; weather 1*)
Power supply voltage	24 VDC ± 20 % ≤ 4.0 W	Weight [kg]	0.6
Flame and fault contact	≤ 42 VDC, ≥ 6 VAC/DC ≤ 0.5 A, ≥ 1.0 mA floating	Protection class	IP66/67 Ex Zone 2
Sensor type	UV-2 (ExI, ExII), IR-1 (ExI, ExII), IR-2 (no Ex)	Operating temperature	Ex Zone 2: - 40 °C...+ 75 °C (UV-2, IR-2) - 40 °C...+ 60 °C (IR-1)
Operating mode	Continuous operation	Ex Zone 2	Ex II 3G, Zone 2// Ex II 3D Zone 22 Ex nA nC IIC T6..T5 Gc X// Ex tc IIIC T85°C Dc X
Analogue output	0/4 ... 20 mA, Load 200 Ohm	Suitable Brackets	Plug-in variant: FH30 FH40 Threaded connection variant FV30 FV40
Cable lengths	max. 250 m Maximum extension over the 3 m of connecting cable at a power supply voltage of 20.5 V	Approval	SIL3

* Comparative evaluation from 1 (very good) to 6 (not suitable)

Compact Flame Scanner F200K / F200K Ex-II (Ex-Zone 2)

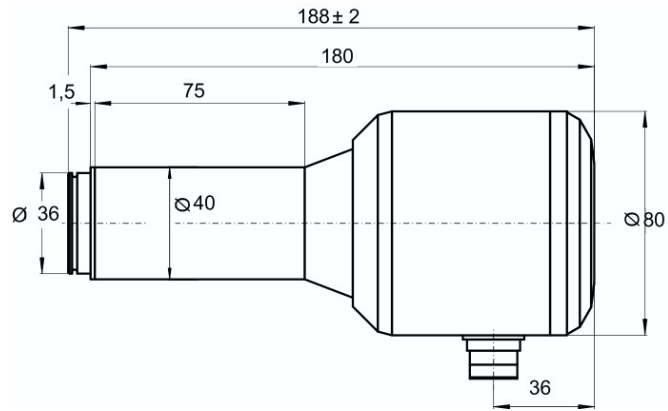

Dimensional drawing flame scanner F200K

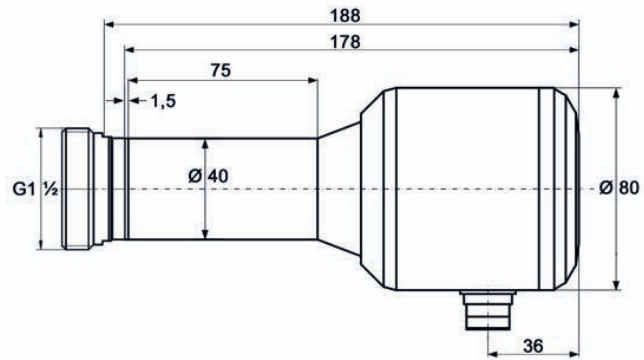

Dimensional drawing flame scanner F200K threaded connection version

Compact Flame Scanner F200K (Ex-Zone 1).

Technical data



Compact flame scanner F200K Ex-Zone 1



Compact flame scanner F200K Ex-Zone 1 with junction box

Item number	659R60... without mains frequency suppression label	Dimensions [mm]	L=198 Ø=60/90
Application	Monitoring of single burner and multi-burner combustion systems	Material	Corrosion-resistant aluminium EN AW 6082 (seawater 2*; weather 1*) nickel plated, varnished RAL 9006 matt
Power supply voltage	24 VDC \pm 20 % \leq 4.0 W	Weight [kg]	1.8 2,0 with junction box
Flame and fault contact	\leq 42 VDC, \geq 6 VAC/DC \leq 0.5 A, \geq 1.0 mA floating	Protection class	IP66
Sensor type	UV-2 IR-1	Operating temperature	UV-2: - 40 °C...+ 65 °C IR-1: - 40 °C...+ 60 °C
Operating mode	Continuous operation	Ex Zone 1	Ex II 2G- Zone 1 // Ex II 2D- Zone 21; Ex db lic T6.T5 Gb/ Ex tb IIIc T80°C, T95°C Db
Analogue output	0/4 ... 20 mA, Load 200 Ohm	Suitable Brackets	FV30 FV40

* Comparative evaluation from 1 (very good) to 6 (not suitable)

Compact Flame Scanner F200K (Ex Zone 1)

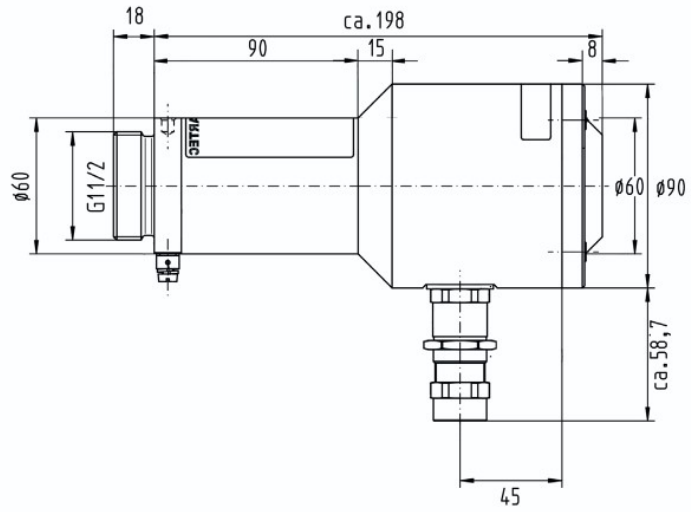

Dimensional drawing flame scanner F200K Ex

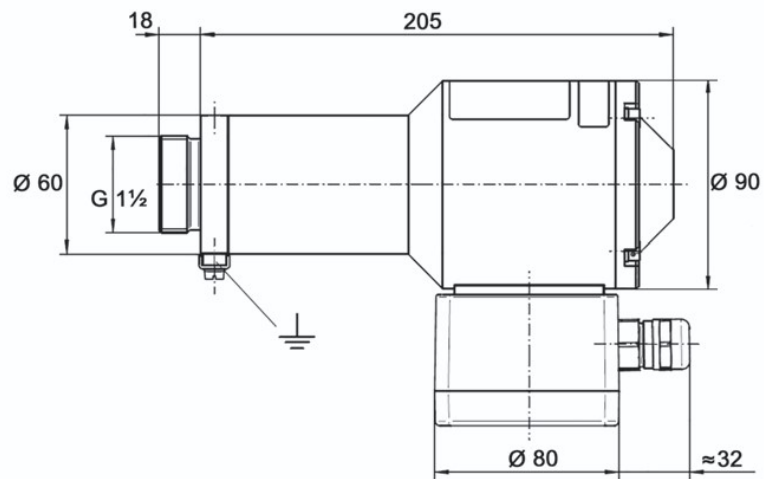

Dimensional drawing flame scanner F200K Ex with junction box

Compact Flame Scanner F300K (Ex Zone 2).

Technical data



F300K with integrated user interface



F300K with LED display

Item number	659A50...	Dimensions [mm]	L=195 Ø=99
Application	Nearly all monitoring tasks	Material	Corrosion-resistant aluminium EN AW 6082 (seawater 2*; weather 1*) or stainless steel
Power supply voltage	24 VDC ± 20 % ≤ 3.7 W	Weight [kg]	1.05 3.6 (stainless steel)
Flame and fault contact (switch NO)	≤ 42 VAC/DC, ≥ 13 VAC/DC ≤ 0.5 A, ≥ 10 mA floating	Protection class	IP66/67
Sensor type	UV-4, UV-4.6, IR-2 F, IR-4 UVIR-1,	Operating temperature	- 40 ... + 85 °C
Operating mode	Continuous operation	Ex Zone 2	Ex nA nC ic IIC T5 (T6) Gc X
Analogue output	0/4 ... 20 mA, Load max. 240 Ohm	Suitable Brackets	FV30 FV40
Cable lengths	Max. 200 m	Approval	SIL3

* Comparative evaluation from 1 (very good) to 6 (not suitable)

Compact Flame Scanner F300K (Ex Zone 2)

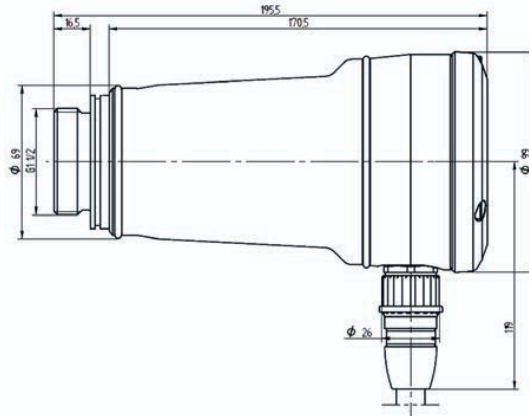

Dimensional drawing flame scanner F300K

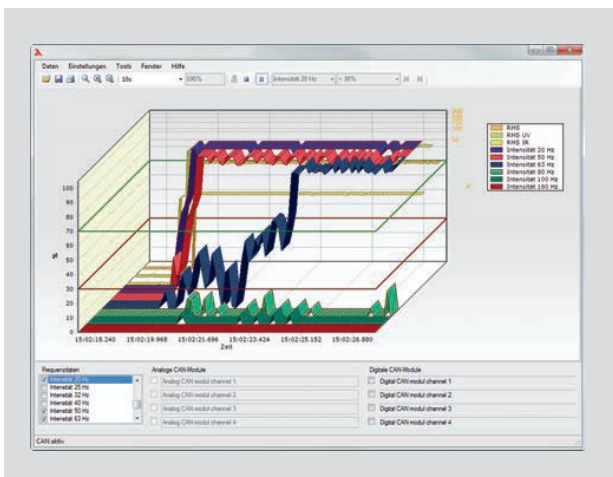

Flamescanner Remote Software item number 659R9000

Flamescanner Remote Software (FRS)

- Connection to the PC via FSB/USB module and adapter cables.
- The flamescanner remote software allows you to set all parameters. In addition, it also offers analysis, data backup and recording functions.
- In addition to the flame scanner data, you can also connect up and record external, analogue and/or digital data by means of FSB modules. All of the data is synchronised.

External User Interface FB30-00/10 for F300K and F350.

Technical data



External User Interface FB30-00, portable



External User Interface FB30-10, control cabinet installation

Item number	659M2100 portable 659M2101 Control cabinet installation	Dimensions [mm]	See dimensional drawings
Application	Same functions as for the integrated user interface	Material	Corrosion-resistant aluminium EN AW 6082 (seawater 2*; weather 1*)
Power supply voltage	24 VDC ± 20%	Weight [kg]	0.3
Power consumption:	< 1 W (< 30 mA)	Protection class	IP67
Communication	FSB-Bus	Ambient temperature	- 40 °C to + 80 °C (from 70 °C display no longer visible)
Connection type	2x2-wire TP shielded, e.g. LiYCY TP 0.34		

* Comparative evaluation from 1 (very good) to 6 (not suitable)

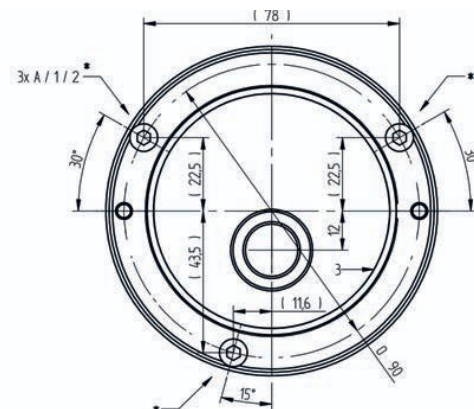
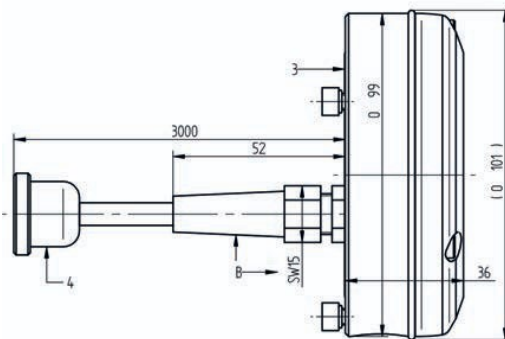

Dimensional drawing External User Interface FB 30-10 - mounting on the control cabinet door

FB30-00/10 External User Interface for F300K

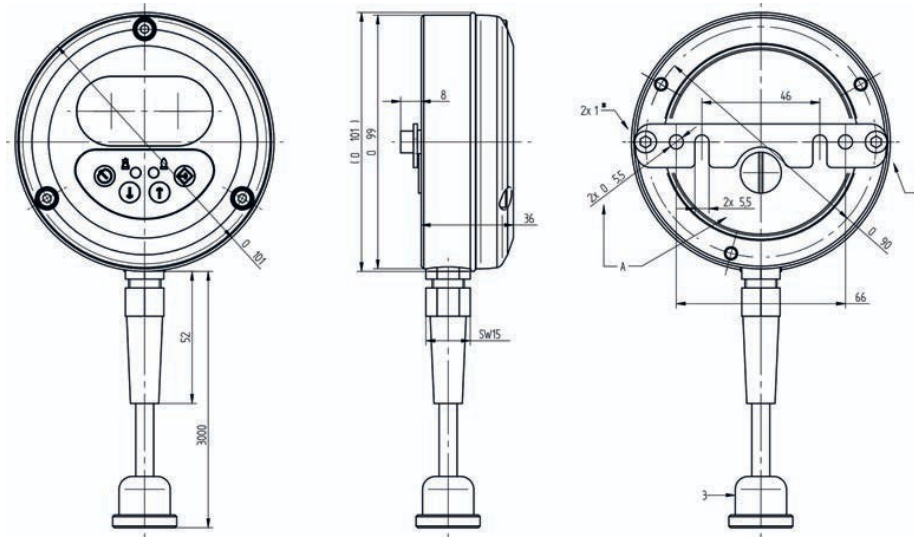

Dimensional drawing external user interface FB30-00 - on-site assembly

A Fixing/mounting holes for M5

1 Cylinder-head screw with M5x8 hexagon socket

2 Mounting bracket

3 Round 5-pin M5 plug-in connector

Commissioning Case in Combination with F300K.

Technical data



Commissioning case front



Commissioning case opened



Commissioning case back side

Item number	659W0202	Dimensions [mm]	HxWxD with undercarriage: 450x420x330 mm Height with extended handle 980 mm
Application	Service and Commissioning support, Test installations, flame analysis, troubleshooting	Material	Aluminium/plastic
Power supply voltage	230 VAC	Weight [kg]	without F300K: 11.2

The Commissioning Case contains the Components shown here



Testing device FFP30



Adapter cable F200K/F300K



Threaded connection FV30-00 with allen key



Threaded connection with purge air coupling and globe joint



Screw adapter G1 1/4" to G1 1"

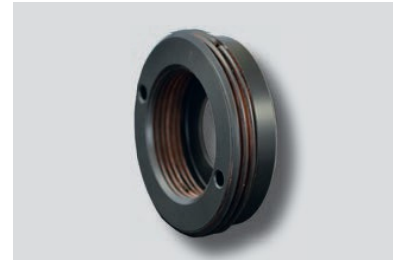

Intermediate adapter M72 to 1 1/2" internal thread



Power supply unit without and optionally with LSB modules



Connecting cable F300K/power supply



Remote software with USB/CAN adapter



USB/connecting cable



FSB Y adapter



F300K Compact Flame Scanner



Ext. FB30-00 user interface



Adapter cable COEN flame scanner-F200K



FSB input modules with connecting cable

Case Contents and Order Information.

Threaded connection FV30-00 Aluminium	659S1201
Power supply unit	7002061-40100ST
FFP30 flame-scanner testing device	659M5000
Connecting cable for power supply	7002060-703ST
FSB Y adapter	659N0801
Adapter cable F200K/F300K	659N1000
Adapter cable F300K/power supply 5 m	7002061-702ST
USB cable for remote software 5 m	7002061-70200
Connecting cable USB/CAN module 2 m	659N0710
F300K remote software, from WIN XP, cable, galvanically isolated, without USB/CAN module	659R9001
USB/CAN module	F300K0006
Globe joint FS10-2 with flange, Gi 2"	659E0105
Purge air coupling, anodised	6512300-80001
Screw adapter Gi 1 1/4" to Ga 1"	659E0000

Separate Parts.

F300K Compact Flame Scanner	659A50
Ext. FB30-00 user interface	659M2100
Adapter cable COEN flame sensor to F200K	659N1100
FSB module for 4 analogue inputs	659M3003
FSB module for 4 digital inputs	659M3004
Connecting cable for FSB modules 20 cm	7002061-703 ST

Comparison Table Flame Scanner/Sensor

Compact

	F200K	F300K
Power supply voltage	+24 VDC	+24 VDC
Operating mode	Continuous operation	Continuous operation
Protection class Ex Zone 1	IP66	X
Protection class Ex Zone 2	IP66/67	IP66/67
Sensor type	UV, IR	UV, IR, UV/IR-1 dual sensor
	UV-2, (Ex Zone 1, Ex Zone 2), IR-1 Ex Zone 1, Ex Zone 2), IR-2 (no Ex Zone)	UV-4, UV-4.6, UV/IR-1, IR-4, (as standard all in Ex Zone 2)
Operating temperature Ex Zone 2	-40 °C ... +75 °C (UV-2)	-40 °C ... + 85 °C
	-40 °C ... +60 °C (IR-1)	
Operating temperature Ex Zone 1	-40 °C ... +64 °C (UV-2)	X
	-40 °C ... +60 °C (IR-1)	
Ex Zone 1	Ex II 2G, Zone 1 // Ex II 2D - Zone 21	X
	Ex db lic. T6 ... T5 Gb // Ex tb IIIC T80 °C, T95 °C Db	
Ex Zone 2	Ex II 3G, Zone 2 // Ex II 3D Zone 22	Ex nA nC ic IIC T5 (T6) Gc X
	Ex nA nC IIC T6 ... T5 Gc X // Ex tc IIIC T85 °C Dc X	
UL and/or Class 1 Div. 2 certified	UL certified/ Cl 1 Div.2	UL certified / Ul + Cl 1 Div. 2
Operation with remote software	No	Yes
Electronic evaluation unit	Integrated in the unit	Integrated in the unit
Safety Integrity Level (SIL)	SIL3	SIL3

Not compact

	FFS07	FFS08	FFS30
Power supply voltage	F152 + 24 VDC	F152 + 24 VDC	F350 + 24 VDC
Operating mode	Continuous operation	Continuous operation	Continuous operation
Protection class	IP66 with Ex Zone 1	X	IP66
	IP67 with Ex Zone 2	no Ex Zone, only as standard IP67	IP67
Sensor type	UV, IR	UV, IR	UV, IR, UV/IR-1 dual sensor
	UV-1, UV-4, IR-1, IR-1T	UV-1, UV-4, IR-1, IR-1 T, IR-1 T/S2	UV-4, UV/IR-1, IR-2, IR-4
Operating temperature	-20 °C ... +65 °C (UV)	-20 °C ... +65 °C	-40 °C ... + 85 °C
	-20 °C ... +60 °C (IR)	-20 °C ... +60 °C	
Ex Zone 1	II 2G Ex d IIC T6 Gb		II 2G Ex d IIC T6 Gb
	II 2D Ex tb IIIC T80 °C Db	X	II 2D Ex tb IIIC T80 °C Db
Ex Zone 2	II 3G Ex nA IIC T5 (T6) Ge X		II 3G Ex nA IIC T5 (T6) Ge X
	II 3D Ex tc IIIC T95 °C Dc x	X	II 3D Ex tc IIIC T95 °C Dc x
Display	X	X	in combination with FB30
UL and/or Class 1 Div. 2 certified	UL 372 · UL listed	UL 372 · UL listed	UL/Cl1 Div. 2
Operation with remote software	No	No	Yes
Electronic evaluation unit	F152	F152	F350
Safety Integrity Level (SIL)	F152 SIL3	F152 SIL3	F350 SIL3

Brackets

General Information about the Brackets.

Valid for all Brackets in this Document

- Purging air must be free from oil and dirt.
- Recommended operating pressure: > 50 mbar above the internal combustion chamber pressure
- Recommended cooling air temperature: min. 20 K below the allowed device temperature
- Recommended air consumption: 5 m³/h
- All weight specifications based on the Brackets without sensor mass
- Length tolerance (total length l) in the technical data: ± 5
- Connection threads other than those described here on request

Specifically for FV30-00, FV30-10, FV40-10, FK41, FK46 and the corresponding stainless steel variants:

Purge air / boiler pressure with dismantled flame scanner: p max. = 0.5 bar.

FV30-15 and with FV40-15

Because of an additional optimisation of the lock washer socket on the screwed body of the bracket, the lock washer socket can withstand a pressure of max. 4 bar from the boiler when the flame scanner is disassembled.

Brackets and Accessories for FFS07 and FFS07 Ex-II/Ex (Ex Zone 2 and 1)

- FV30-00 Threaded connection / FV30-01 (stainless steel) / FV30-07 (seawater resistant)
- FV30-10 Threaded connection with purge air coupling / FV30-11 (stainless steel) / FV30-17 (seawater resistant)
- FV40-10 Threaded connection with purge air coupling and globe joint
- FR20-01 Bracket with 90° deflecting mirror
- FH30-00 Plug-in bracket
- FH30-10 Plug-in bracket and purge air coupling
- FH40-10 Plug-in bracket with purge air coupling and globe joint
- FS30 Cooling air housing
- FS36 Cooling air housing with bracket, detachable, adjustable
- FS41 Cooling air housing and globe joint

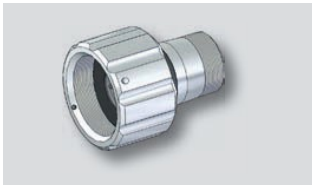

Threaded connection FV30-00 and FV30-01 (stainless steel) and FV30-07 (seawater resistant)

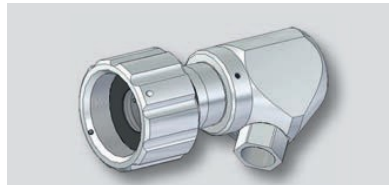

Threaded connection with purge air coupling FV30-10 and FV30-11 (stainless steel) and FV30-17 (seawater resistant)

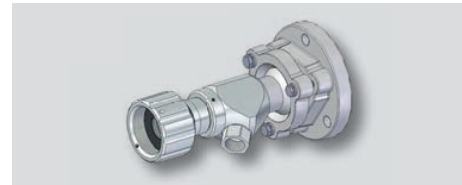

Threaded connection with purge air coupling and globe joint FV40-10 and FV40-11 (stainless steel)

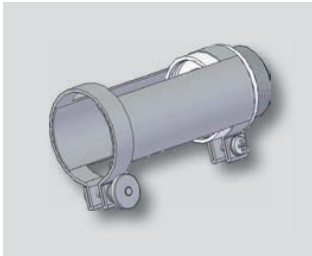

Plug-in bracket FH30-00

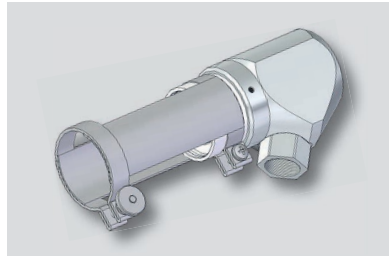

Plug-in bracket and purge air coupling FH30-10

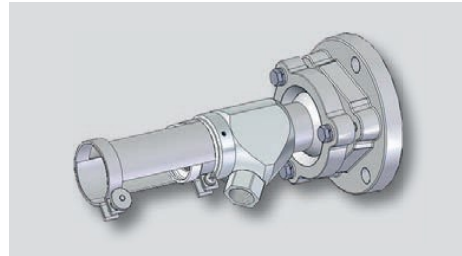

Plug-in bracket with purge air coupling and globe joint FH40-10



Cooling air housing FS30



Cooling air housing with bracket, detachable, adjustable FS36



Cooling air housing and globe joint FS41



Bracket with 90° deflecting mirror FR20-01

Brackets and Accessories for FFS08

- FS60-00 Bracket
- FS60-10 Bracket with adjusting ring
- FS65 Cooling air housing
- FH80-00 Adjustment bracket
- FH80-10 Adjustment bracket with globe joint



Bracket FS60-00



Bracket with adjusting ring FS60-10

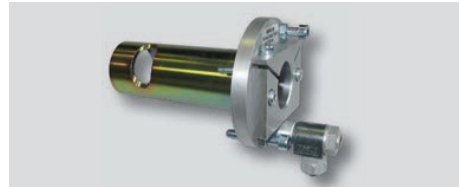

Cooling air housing FS65

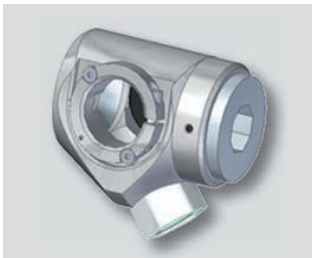

Adjustment bracket FH80-00

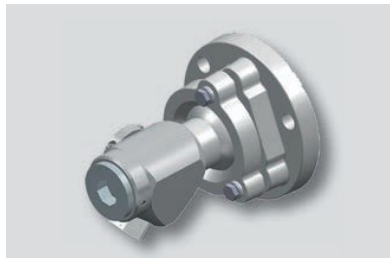

Adjustment bracket with globe joint FH80-10

Brackets and Accessories for FFS30 Ex-II/Ex (Ex Zone 2 and 1)

- FV30-00 Threaded connection / FV30-01 (stainless steel) / FV30-07 (seawater resistant)
- FV30-10 Threaded connection with purge air coupling / FV30-11 (stainless steel) / FV30-17 (seawater resistant)
- FV30-15 Threaded connection with purge air coupling for 4 bar
- FV40-10 Threaded connection with purge air coupling and globe joint / FV40-11 (stainless steel)
- FV40-15 Threaded connection with purge air coupling and globe joint for 4 bar
- FS30 Cooling air housing
- FS36 Cooling air housing with bracket, detachable, adjustable
- FS41 Cooling air housing and globe joint
- FR20-01 Bracket with 90° deflecting mirror

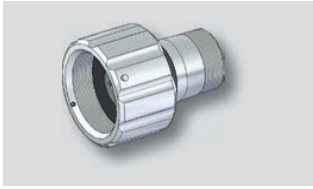

Threaded connection FV30-00 and FV30-01 (stainless steel), V30-07 (seawater resistant)

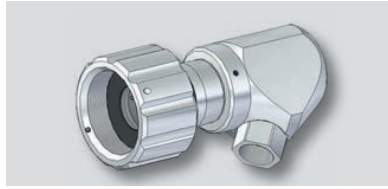

Threaded connection with purge air coupling FV30-10, FV30-11 (stainless steel) and FV30-17 (seawater resistant)

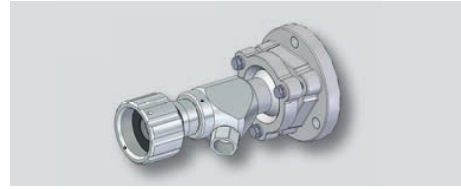

Threaded connection with purge air coupling and globe joint FV40-10 and FV40-11 (stainless steel)



Cooling air housing FS30



Cooling air housing with bracket, detachable, adjustable FS36

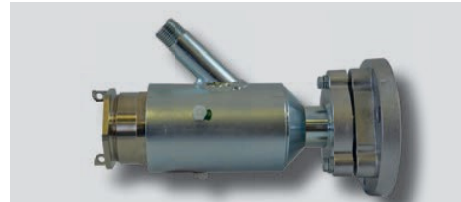

Cooling air housing and globe joint FS41



Bracket with 90° deflecting mirror FR20-01

Brackets and Accessories for F200K

- FV30-00 Threaded connection / FV30-01 (stainless steel) / FV30-07 (seawater resistant)
- FV30-10 Threaded connection with purge air coupling / FV30-11 (stainless steel) / FV30-17 (seawater resistant)
- FV30-15 Threaded connection with purge air coupling for 4 bar
- FV40-10 Threaded connection with purge air coupling and globe joint / FV40-11 (stainless steel)
- FV40-15 Threaded connection with purge air coupling and globe joint for 4 bar
- FH30-00 Plug-in bracket
- FH30-10 Plug-in bracket and purge air coupling
- FH40-10 Plug-in bracket with purge air coupling and globe joint
- FR20-01 Bracket with 90° deflecting mirror
- FS50 Cooling air housing
- FS51 Cooling air housing and globe joint
- FS56 Bracket, detachable and adjustable

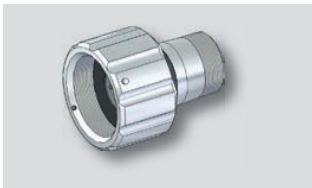

Threaded connection FV30-00 and FV30-01 (stainless steel), FV30-07 (seawater resistant)

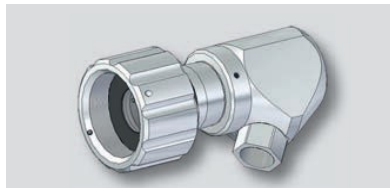

Threaded connection with purge air coupling FV30-10 and FV30-11 (stainless steel) and FV30-17 (seawater resistant)

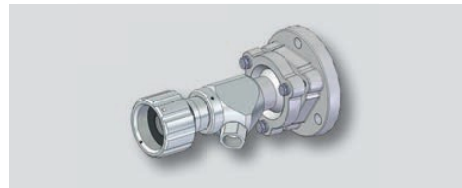

Threaded connection with purge air coupling and globe joint FV40-10 and FV40-11 (stainless steel)

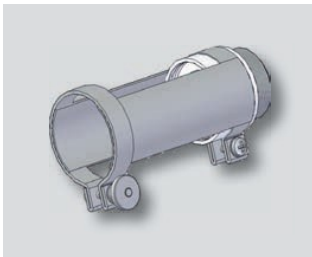

Plug-in bracket FH30-00

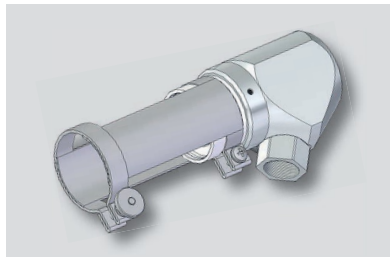

Plug-in bracket and purge air coupling FH30-10

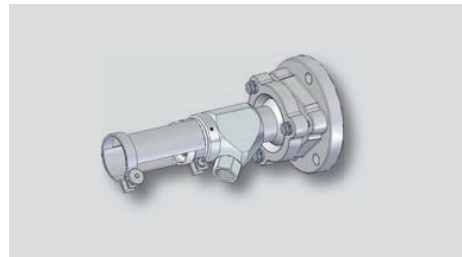

Plug-in bracket with purge air coupling and globe joint FH40-10



FR20-01 Bracket with 90° deflecting mirror

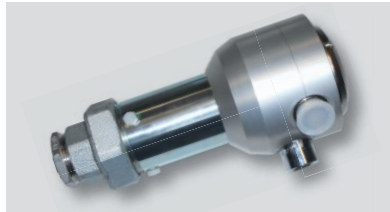

Cooling air housing FS50 (also available with extended air outlet)

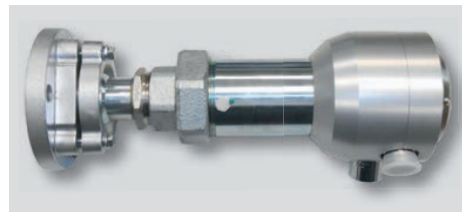

Cooling air housing and globe joint FS51



Bracket, detachable and adjustable FS56



Heated Thermal Jacket

Brackets and Accessories for F300K

- FV30-00 Threaded connection / FV30-01 (stainless steel) / FV30-07 (seawater resistant)
- FV30-10 Threaded connection with purge air coupling / FV30-11 (stainless steel) / FV30-17 (seawater resistant)
- FV30-15 Threaded connection with purge air coupling for 4 bar
- FV40-10 Threaded connection with purge air coupling and globe joint / FV40-11 (stainless steel)
- FV40-15 Threaded connection with purge air coupling and globe joint for 4 bar
- FR20-01 Bracket with 90° deflecting mirror
- FK30 Cooling air housing
- FK41 Cooling air housing with purge air coupling and globe joint
- FK46 Cooling air housing with purge air coupling and FS35 (detachable bracket)

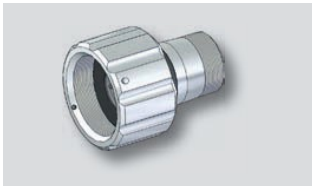

Threaded connection FV30-00 and FV30-01 (stainless steel), V30-07 (seawater resistant)

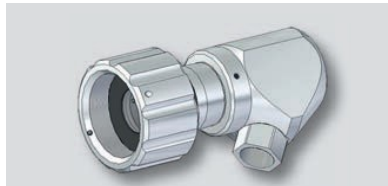

Threaded connection with purge air coupling FV30-10, FV30-11 (stainless steel) and FV30-17 (seawater resistant)

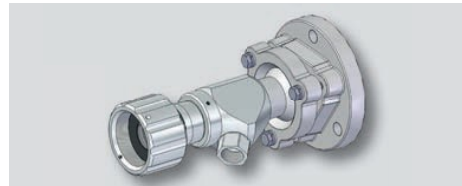

Threaded connection with purge air coupling and globe joint FV40-10 and FV40-11 (stainless steel)



Cooling air housing FK30

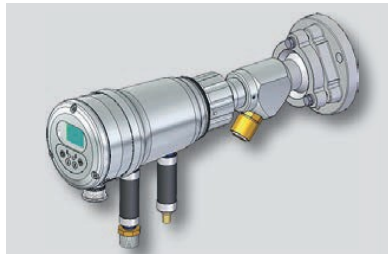

Cooling air housing with purge air coupling and globe joint FK41

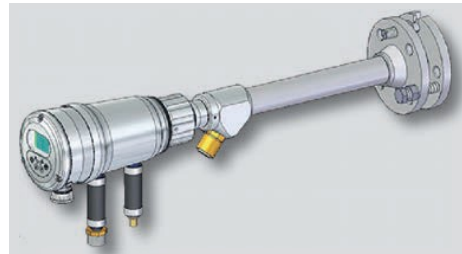

Cooling air housing with purge air coupling and FS35 - FK46



FR20-01 Bracket with 90° deflecting mirror

Assignment of Brackets to Flame Scanners.

Brackets for FFS07

- FV30-00 Threaded connection / FV30-11 (stainless steel) / FV30-07 (seawater resistant)
- FV30-10 Threaded connection with purge Air coupling / FV30-11 (stainless steel) / FV30-17 (seawater resistant)
- FV40-10 Threaded connection with purge Air coupling and globe joint
- FR20-01 Bracket with 90° deflecting mirror
- FH30-00 Plug-in bracket
- FH30-10 Plug-in bracket and purge Air coupling
- FH40-10 Plug-in bracket with purge Air coupling and globe joint
- FS30 Cooling air housing
- FS36 Cooling air housing with bracket, detachable, adjustable
- FS41 Cooling air housing and globe joint

Brackets for FFS08

- FS60-00 Bracket
- FS60-10 Bracket
- FS65 Cooling air housing
- FH80-00 Bracket
- FH80-10 Bracket

Brackets for FFS30

- FV30-00 Threaded connection / FV30-01 (stainless steel) / FV30-07 (seawater resistant)
- FV30-10 Threaded connection with purge air coupling / FV30-11 (stainless steel) / FV30-17 (seawater resistant)
- FV30-15 Threaded connection with purge air coupling for 4 bar
- FV40-10 Threaded connection with purge air coupling and globe joint / FV40-11 (stainless steel)
- FV40-15 Threaded connection with purge air coupling and globe joint for 4 bar
- FR20-01 Bracket with 90° deflecting mirror
- FS30 Cooling air housing
- FS36 Cooling air housing with bracket, detachable, adjustable
- FS41 Cooling air housing and globe joint

Brackets for F200K

- FV30-00 Threaded connection / FV30-01 (stainless steel) / FV30-07 (seawater resistant)
- FV30-10 Threaded connection with purge Air coupling / FV30-11 (stainless steel) / FV30-17 (seawater resistant)
- FV30-15 Threaded connection with purge Air coupling for 4 bar
- FV40-10 Threaded connection with purge Air coupling and globe joint / FV40-11 (stainless steel)
- FV40-15 Threaded connection with purge Air coupling and globe joint for 4 bar
- FH30-00 Plug-in bracket
- FH30-10 Plug-in bracket and purge Air coupling
- FH40-10 Plug-in bracket with purge Air coupling and globe joint
- FR20-01 Bracket with 90° deflecting mirror
- FS50 Cooling air housing
- FS51 Cooling air housing and globe joint
- FS56 Cooling air housing with bracket, detachable, adjustable

Brackets for F300K

- FV30-00 Threaded connection and FV30-01 (stainless steel) / FV30-07 (seawater resistant)
- FV30-10 Threaded connection with purge Air coupling / FV30-11 (stainless steel) / FV30-17 (seawater resistant)
- FV30-15 Threaded connection with purge Air coupling for 4 bar
- FV40-10 Threaded connection with purge Air coupling and globe joint and FV40-11 (stainless steel)
- FV40-15 Threaded connection with purge Air coupling and globe joint for 4 bar
- FR20-01 Bracket with 90° deflecting mirror
- FK30 Cooling air housing
- FK41 Cooling air housing with purge Air coupling and globe joint
- FK46 Cooling air housing with purge Air coupling and FS35 (detachable bracket)

Table, Brackets and Cooling air housing

Can be used for:

Designation/type	F200K	F300K	FFS30	FFS07-V	FFS08	Type
Screw-in bracket FV30-00, G 1" external thread, for screw fastening, without purge air connection, anodised aluminium	X	X	X	X	-	659S1201
Screw-in bracket FV30-07, G 1" external thread, for screw fastening, without purge air connection, anodised aluminium, seawater resistant	X	X	X	X	-	659S1209
Screw-in bracket FV30-01, G 1" external thread for screw fastening, without purge air connection, stainless steel 1.4404	X	X	X	X	-	659S1202
Screw-in bracket FV30-02, 1" NPT-thread for screw fastening, without purge air connection, anodised aluminium	X	X	X	X	-	659S1205
Screw-in bracket FV30-10, G 1" internal thread, for screw fastening, with purge air connection G 1/2" internal thread, anodised aluminium	X	X	X	X	-	659S1200
Screw-in bracket FV30-17, G 1" external thread, for screw fastening, without purge air connection, anodised aluminium, seawater resistant	X	X	X	X	-	659S1217
Screw-in bracket FV30-11 with G 1" internal thread, for screw fastening, with purge air connection G 1/2" internal thread, stainless steel 1.4404	X	X	X	X	-	659S1211
Screw-in bracket FV30-15, for excess pressure up to 4 bar, G 1" internal thread, for screw fastening, with purge air connection G 1/2" internal thread, anodised aluminium	X	X	X	X	-	659S1215
Globe joint FS10 with G 1" external thread, for screw-in bracket FV30.../FH30..., anodised aluminium	X ¹⁾	X	X	X ¹⁾	-	659E0106
Counterpart (welding neck flange) to globe joint FS10, for direct welding on 1" tubes, stainless steel 1.4301	X	X	X	X	-	659S3102
Globe joint FS11 with G 1" external thread for screw-in bracket FV30.../FH30..., stainless steel 1.4404	X ¹⁾	X	X	X ¹⁾	-	659S0411
Counterpart (welding neck flange) to globe joint FS11, for direct welding on 1" tubes, stainless steel 1.4404	X	X	X	X	-	659S3101
Ball-and-socket joint FV40-10, globe joint, for screw fastening, with purge air connection G 1/2" internal thread, anodised aluminium	X	X	X	X	-	659S1300
Ball-and-socket joint FV40-11, globe joint, for screw fastening, with purge air connection G 1/2" internal thread, stainless steel 1.4404	X	X	X	X	-	659S1311
Ball-and-socket joint FV40-15, for excess pressure up to 4 bar, globe joint, for screw fastening, with purge air connection G 1/2" internal thread, anodised aluminium	X	X	X	X	-	659S1315
Ball-and-socket joint FK46, with cooling air housing and purge air connection G 1/2" internal thread, detachable, adjustable, anodised aluminium	-	X	-	-	-	659S1400
Ball-and-socket joint FK41, with cooling air housing and purge air connection G 1/2" internal thread and globe joint. Anodised aluminium	-	X	-	-	-	659S1401
Cooling air housing FK30, air couplings G 1/2" external thread	-	X	-	-	-	659S1100
Cooling air housing FK31, air couplings G 1/2" external thread, seawater resistant	-	X	-	-	-	659S1101
Quick-release coupling 1/2" with locking socket, for purge air connection, brass, hose connection 6/8 mm	X	X	-	-	-	659ES126
Quick-release coupling 1/2" with locking socket, for purge air connection, stainless steel 1.4571, hose connection 6/8 mm	X	X	-	-	-	659ES125
Cooling air housing FS50 with air coupling G 1/2" internal thread	X ¹⁾	-	-	-	-	659R6109
Ball-and-socket joint FS56, detachable, adjustable, with cooling air housing, air coupling G 1/2" internal thread	X ¹⁾	-	-	-	-	659R6099
Ball-and-socket joint FS51, with globe joint, with cooling air housing, air coupling G 1/2" internal thread	X ¹⁾	-	-	-	-	659R6107
Cooling air housing FS30, purge air connection G 1/2" internal thread	-	-	X ²⁾	X ¹⁾²⁾	-	659R0109
Ball-and-socket joint FS36, detachable, adjustable, with cooling air housing, air coupling G 1/2" internal thread	-	-	X ²⁾	X ¹⁾²⁾	-	659R0099
Ball-and-socket joint FS41, with globe joint and cooling air housing, air coupling G 1/2" internal thread	-	-	X ²⁾	X ¹⁾²⁾	-	659R0107

¹⁾ also for plug-in variant ²⁾ also for Ex1

Can be used for:

Designation/type	F200K Plug-in	F200K-V F300K	FFS30	FFS07 Plug-in	FFS08	Type
Screw-in bracket FH30-00, G 1" external thread with plug-in bracket, galvanized steel / plastic	X	-	-	X	-	659S1501
Screw-in bracket FH30-10, G 1" internal thread with plug-in bracket and purge air connection G 1/2" internal thread, anodised aluminium / galvanized sheet steel / plastic	X	-	-	X	-	659S1500
Ball-and-socket joint FH40-10 with plug-in bracket, with purge air connection G 1/2" internal thread and globe joint	X	-	-	X	-	659S1600
Bracket FS60-00, without adjusting ring	-	-	-	-	X	659S0500
Bracket FS60-10, with adjusting ring	-	-	-	-	X	659S0510
FH80-00 adjustable holder	-	-	-	-	X	659S2100
FH80-10 adjustable holder with globe joint	-	-	-	-	X	659S2110
Cooling air housing FS65 with bracket	-	-	-	-	X	659R3109

Threaded Connection FV30-00 and FV30-01 (stainless steel) and FV30-07 (seawater resistant).

Technical data

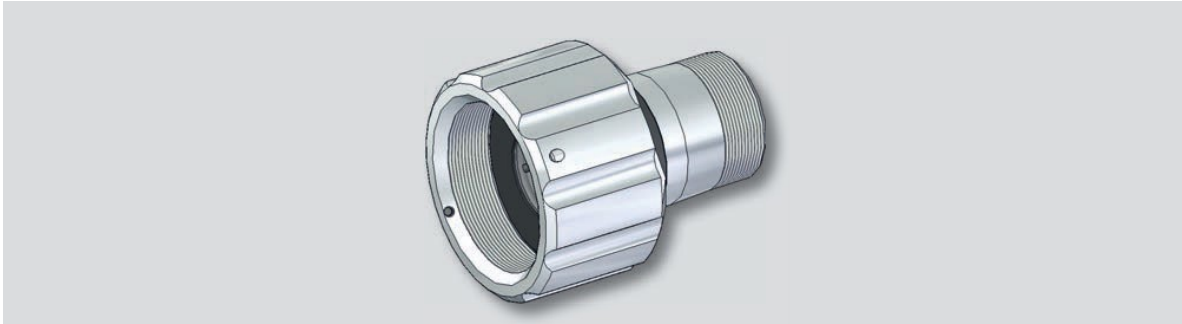

Threaded connection FV30-00 and FV30-01 und FV30-07

Possible applications	FFS30, FFS30 Ex, FFS07/V, FFS07/V Ex, F200K/V, F200K Ex, F300K	Dimensions [mm] Bracket with FFS30/FFS07 with F200K/V with F200K Ex with F300K	l	b	h
Item number	659S1201 / 659S1209 Aluminium 659S1202 Stainless steel		76	--	60
Material	Anodised aluminium/plastic, Stainless steel (V4A)/plastic		234	40	60
Air connection	--		253	80	60
Weight [kg]	0.30 Aluminium 0.55 Stainless steel	Spare parts for Aluminium Spare parts for stainless steel and Aluminium Spare parts for stainless steel	276	90	60
			258	99	60
			659E0102 Lock washer, quartz glass d= 25 mm 659ES120 Lock washer socket incl. lock washer 659ES121 O-rings (5 ea.)		

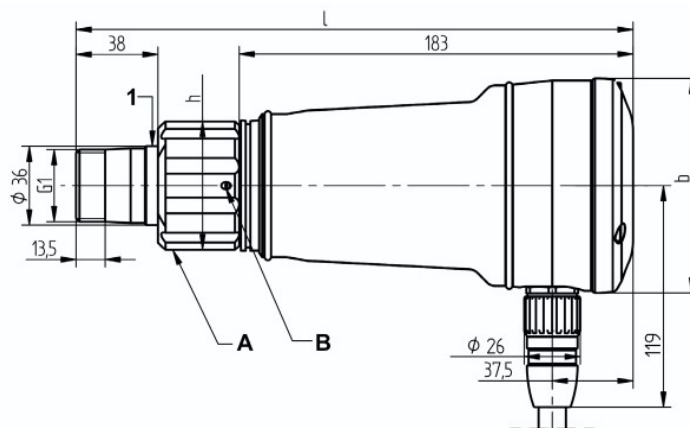

Dimensional drawing FV30-00 / FV30-01 / FV30-07 with flame scanner F300K

- 1 Insulating part
- A Crown nut tightened by hand or with SW 46
- B Locking device tightened with Allen key for M3

Threaded Connection with Purge Air connection FV30-10 and FV30-11 (stainless steel) and FV30-17 (seawater resistant).

Technical data

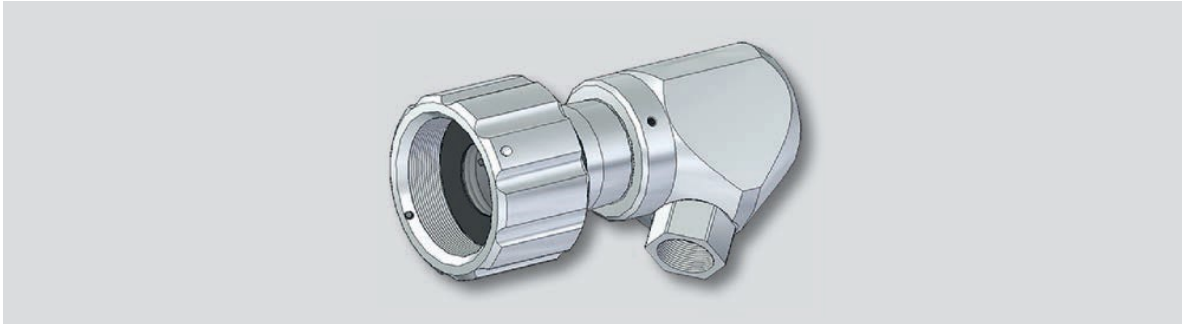

Threaded connection with purge air connection FV30-10, FV30-11 (stainless steel) and FV30-17 (seawater resistant)

Possible applications	FFS30, FFS30 Ex, FFS07/V, FFS07/V Ex, F200K/V, F200K Ex, F300K	Dimensions [mm]	l	b	h
Item number	659S1200 / 659S1200/NPT / 659S1217 Aluminium 659S1211 Stainless steel	Bracket	126	--	70
		with FFS30/FFS07	284	40	70
		with F200K/V	303	80	70
		with F200K Ex	326	90	70
Material	Anodised aluminium/plastic, Stainless steel (V4A)/plastic	with F300K	308	99	70
Air connection	Hexagonal nipple, G 1/2" i	Spare parts for Aluminium	659E0102 Lock washer, quartz glass d= 25 mm		
Weight [kg]	0.50 Aluminium 1.23 Stainless steel	Spare parts for stainless steel and Aluminium	659ES120 Lock washer socket incl. lock washer		
		Spare parts for stainless steel	659ES121 O-rings (5 ea.)		

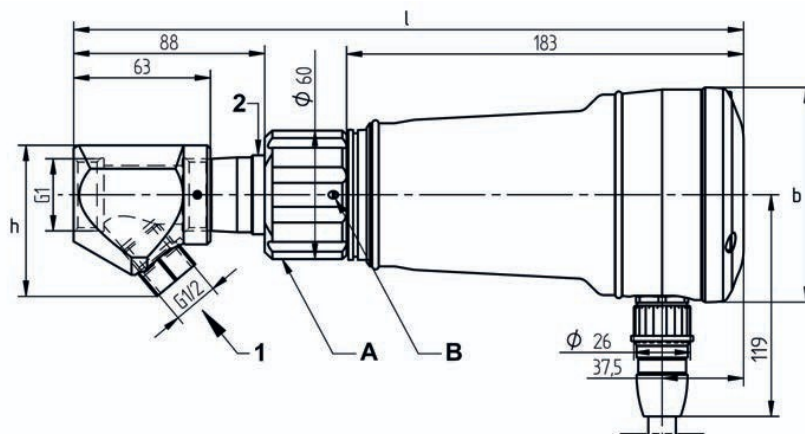

Dimensional drawing FV30-10 / FV30-11 / FV30-17 with flame scanner F300K

- 1 Purge air
- 2 Insulating part
- A Crown nut tightened by hand or with SW 46
- B Locking device tightened with Allen key for M3

Threaded Connection with Purge Air Connection FV30-15 excess Pressure.

Technical data

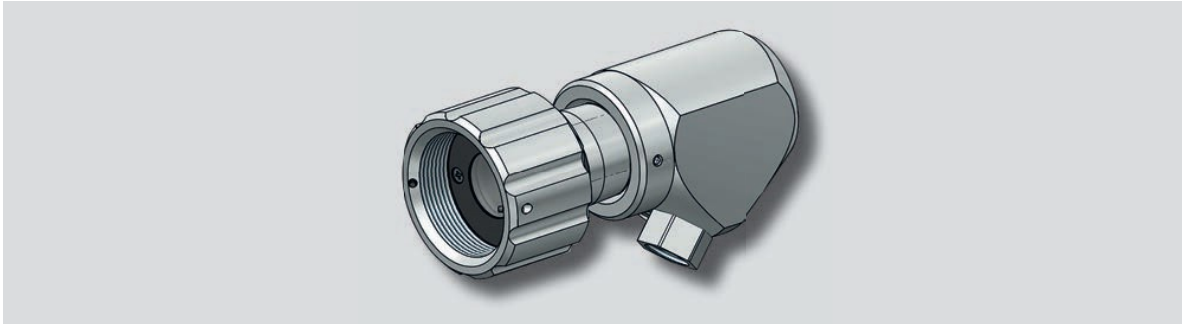

Threaded connection with purge air connection FV30-15 excess pressure

Possible applications	F200KV, F300K with boiler pressure 4 bar
Item number	659S1203
Material	Anodised aluminium/plastic
Air connection	G 1/2"
Weight [kg]	0.50 Aluminium 1.23 Stainless steel

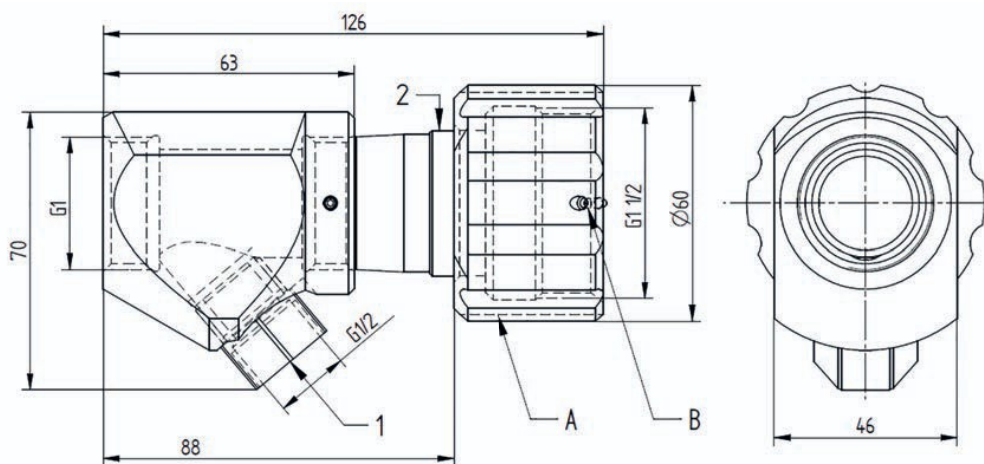

Dimensional drawing FV30-15

- | | | | |
|---|--|---|----------------------------|
| 1 | Basic body, bracket (purge air coupling), screwed body | A | Crown nut SW 46 |
| 2 | Crown nut with ISO sleeve | B | Lock with Allen key for M3 |

Threaded Connection with Purge Air Coupling and Globe Joint FV40-10 and FV40-11.

Technical data

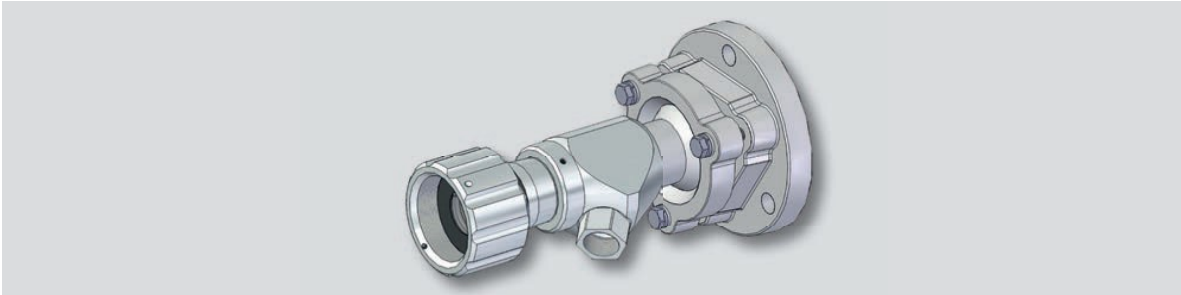

Threaded connection with purge air coupling and globe joint FV40-10/11

Possible applications	FFS30, FFS30 Ex, FFS07/V, FFS07/V Ex, F200K/V, F200K Ex, F300K	Dimensions [mm] Bracket with FFS07 with F200K/V with F200K Ex with F300K	l	b	h
Item number	659S1300 Aluminium 659S1311 Stainless steel		195	--	110
Material	Anodised aluminium/plastic, Stainless steel (V4A)/plastic		353	40	110
Air connection	Hexagonal nipple, G 1/2" i		372	80	110
Weight [kg]	1.35 Aluminium 3.16 Stainless steel		395	90	110
		Spare parts for Aluminium Spare parts for stainless steel and Aluminium Spare parts for stainless steel	659ES120 Lock washer socket 659ES121 O-rings (5 ea.) 659E0102 Lock washer, quartz glass d= 25 mm		

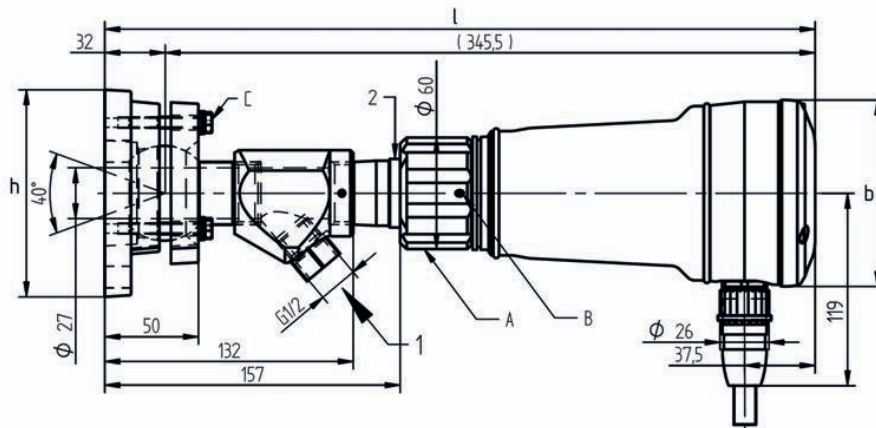

Dimensional drawing FV40-10 with flame scanner F300K

- 1 Purge air
- 2 Insulating part
- A Crown nut tightened by hand or using SW 46
- B Locking device tightened with Allen key for M3
- C Locking the globe joint using SW 10

Plug-in Bracket FH30-00.

Technical data

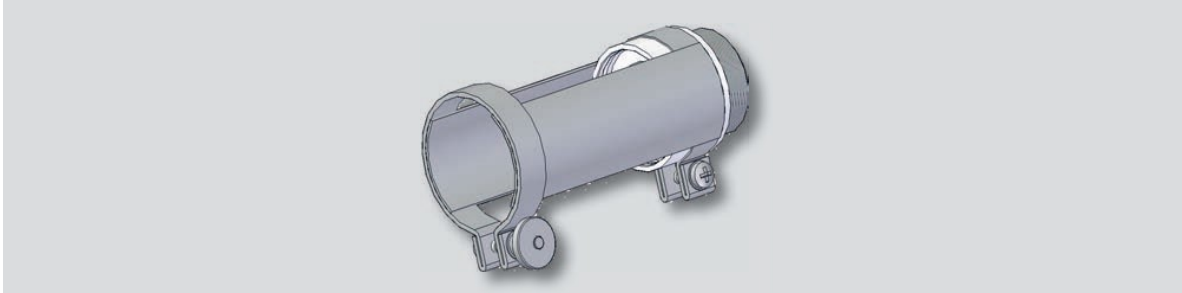

Plug-in Bracket FH30-00

Possible applications	FFS07, FFS07 Ex Zone 2, F200K, F200K Ex Zone 2	Dimensions [mm] Bracket with FFS07 with F200K	l	b	h
			106	--	40
			194	40	40
Item number	659S1501		212	80	40
Material	Galvanized steel, plastic	Spare parts	659ES150 Lock washer socket 659ES151 bracket, welded 659E0102 Lock washer, quartz glass d= 25 mm		
Weight [kg]	0.15				

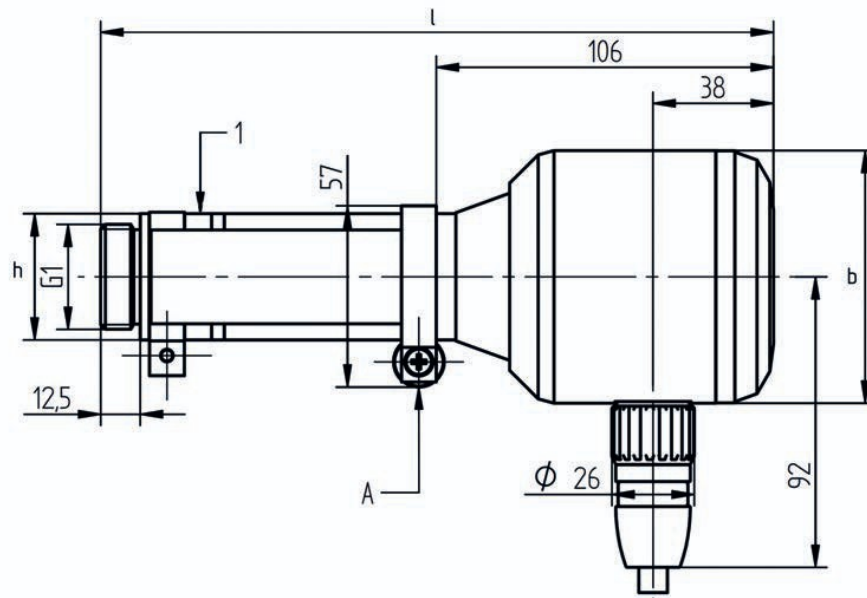

Dimensional drawing FH30-00 with flame scanner F200K

- 1 Insulating part
- A Stretching screw tightened by hand

Plug-in Bracket with Purge Air Coupling FH30-10.

Technical data

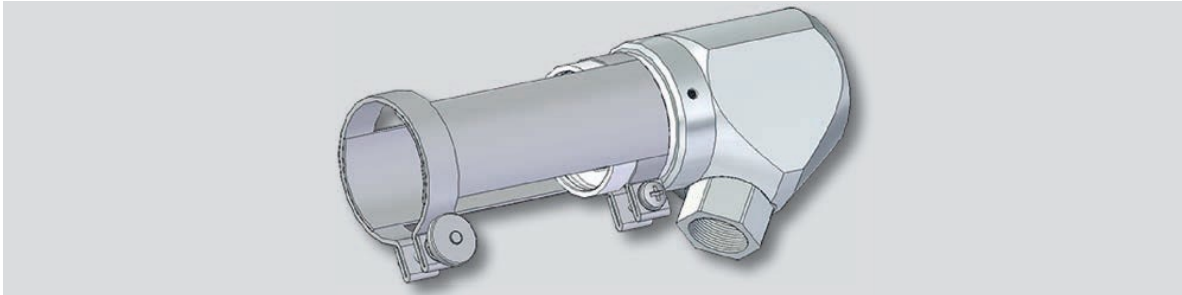

Plug-in bracket with purge air coupling FH30-10

Possible applications	FFS07, FFS07 Ex Zone 2, F200K, F200K Ex Zone 2	Dimensions [mm]	l	b	h	
Item number	659S1500		Bracket with FFS07	156	--	70
Material	Anodised aluminium, Galvanized steel, plastic		with F200K	244	40	70
Air connection	Hexagonal nipple, G 1/2" i	Spare parts	659ES150 Lock washer socket			
Weight [kg]	0.35		659ES151 bracket, welded			
			659E0102 Lock washer, quartz glass d= 25 mm			

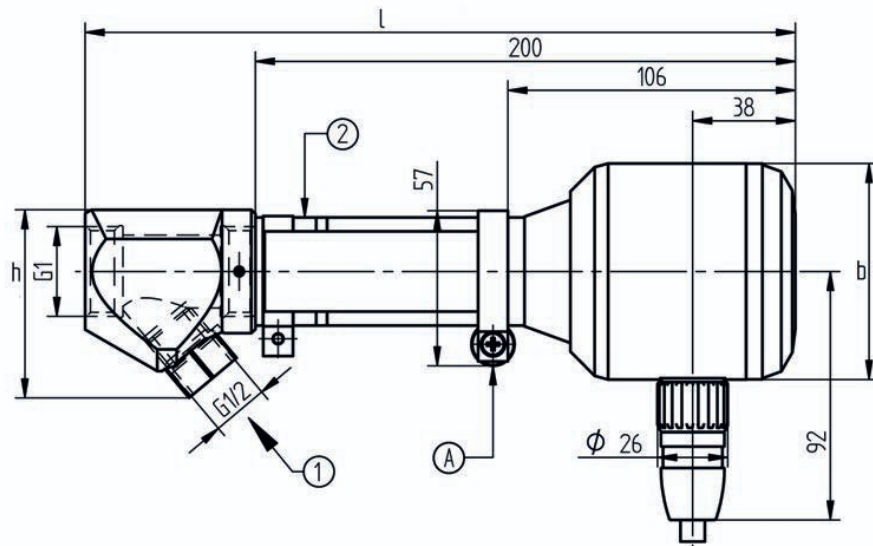

Dimensional drawing FH30-10 with flame scanner F200K

- 1 Purge air
- 2 Insulating part
- A Stretching screw tightened by hand

Plug-in Bracket with Purge Air Coupling and Globe Joint FH40-10.

Technical data

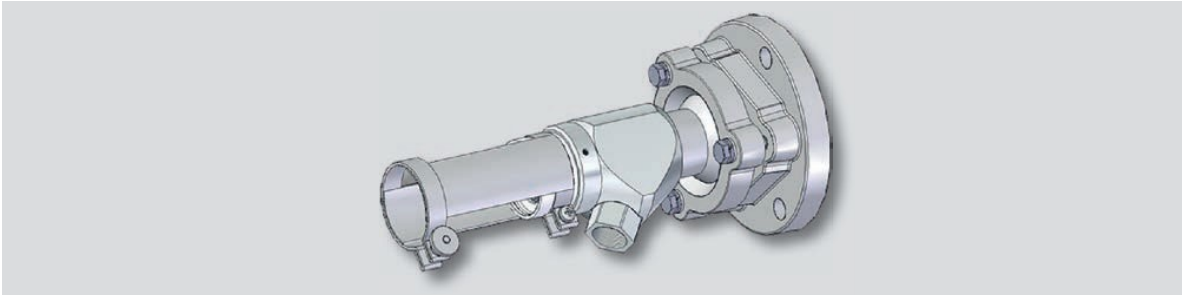

Plug-in Bracket with Purge Air Coupling and Globe Joint FH40-10

Possible applications	FFS07, FFS07 Ex Zone 2, F200K, F200K Ex Zone 2	Dimensions [mm]	l	b	h
Item number	659S1600		225	--	110
Material	Anodised aluminium, Galvanized steel, plastic	with FFS07	313	40	110
Air connection	Hexagonal nipple, G 1/2" i	with F200K	332	80	110
		Weight [kg]	1.20		
		Spare parts	659ES150 Lock washer socket 659ES151 Bracket, welded 659E0102 Lock washer, quartz glass d= 25 mm		

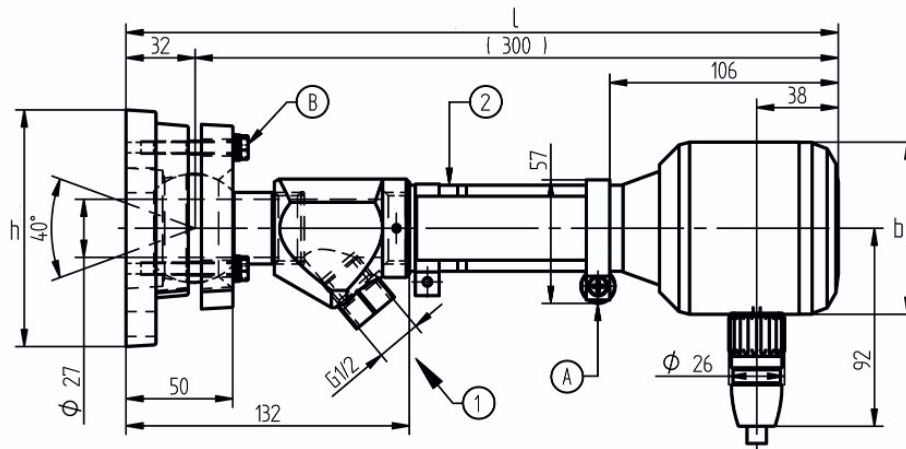

Dimensional drawing FH40-10 with flame scanner F200K

- 1 Purge air
- 2 Insulating part
- A Stretching screw tightened by hand
- B Locking the globe joint using SW 10

Bracket FS60-00.

Technical data



Bracket FS60-00

Possible applications	FFS08	Dimensions [mm] Bracket with FFS08	l	b	h
Item number	659S0500		133	56	40
Material	Anodised aluminium	Weight [kg]	0.05		

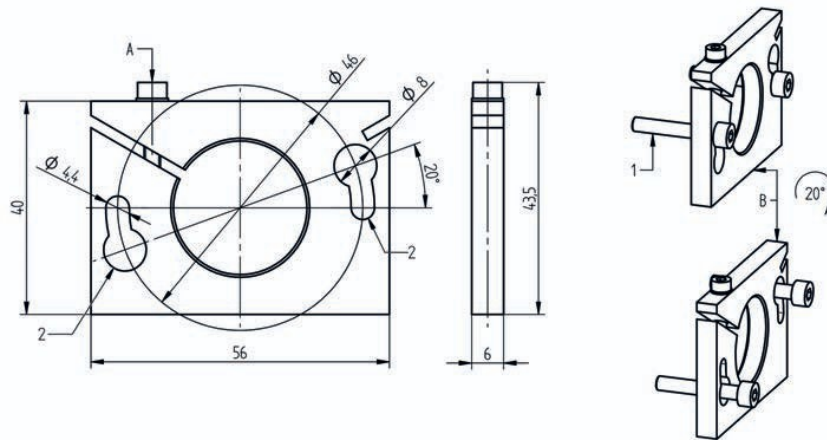

Dimensional drawing FS60-00 for flame sensor FFS08

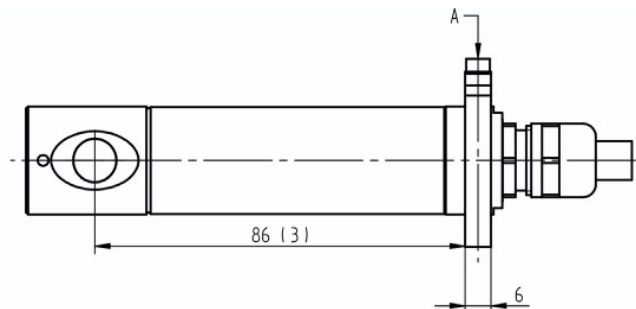

Dimensional drawing FS60-00 with flame sensor FFS08

- A** Stretching screw tightened with Allen key for M3
- B** Disassembly by loosening fastening screws M4 and 20° expansion of the rotary retaining plate
- 1** Fastening screws M4 (not included in delivery), rated length installation-dependent
- 2** Bores for fastening screws ISO4762 - M4..., not included in delivery, rated length installation-dependent
- 3** max. immersion depth of flame sensor FFS08, with extension L max. = 166 mm

Bracket with adjusting Ring FS60-10.

Technical data



Bracket with adjusting Ring FS60-10

Possible applications	FFS08	Dimensions [mm]	l	b	h
Item number	659S0510		Bracket with FFS08	133	56
Material	Anodised aluminium	Weight [kg]	0.05		

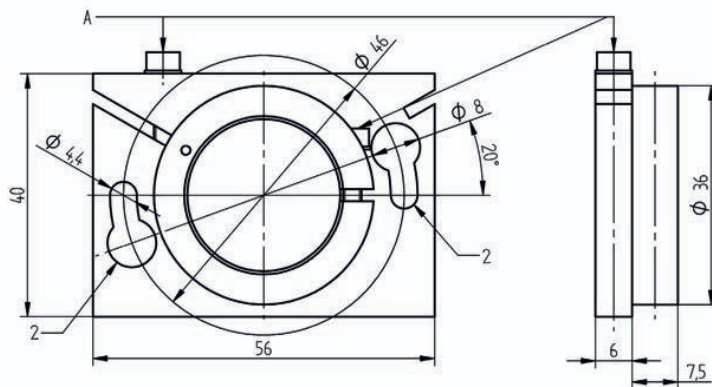

Dimensional drawing FS60-10 for flame sensor FFS08

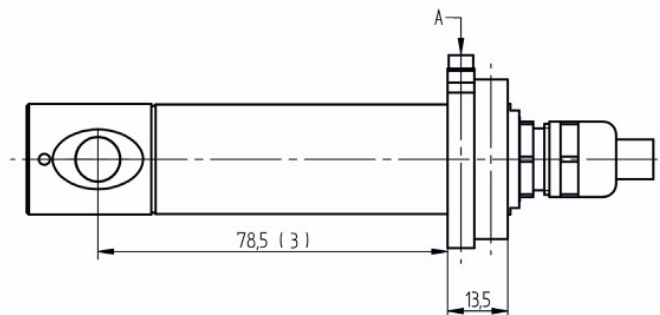

Dimensional drawing FS60-10 with flame sensor FFS08

- A Stretching screw tightened with Allen key for M3
- 2 Bores for fastening screws ISO4762 - M4..., not included in delivery, rated length installation-dependent
- 3 max. immersion depth of flame sensor FFS08, with extension L max. = 158.5 mm

Adjustment Bracket FH80-00.

Technical data

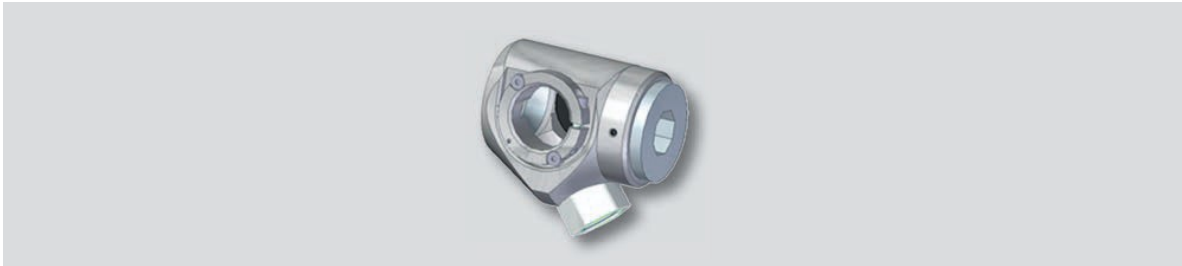

Adjustment bracket FH80-00

Possible applications	FFS08	Dimensions [mm]	l	b	h
Item number	659S2100		Bracket	--	46
Material	Anodised aluminium, plastic	with FFS08	118	46	70
Air connection	Hexagonal nipple G 1/2" i	Weight [kg]	0.5		

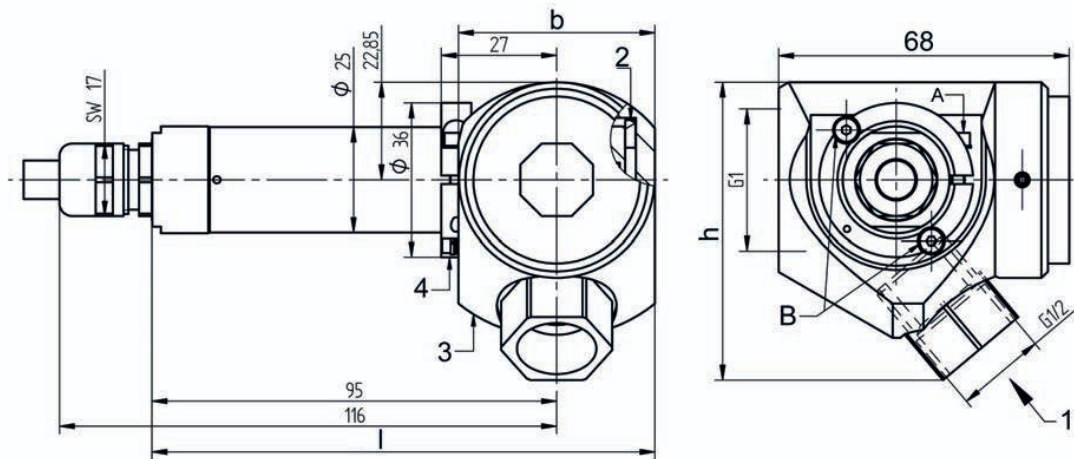

Dimensional drawing FS80-00 with flame sensor FFS06, FFS08

- 1 Purge air
- 2 Insulating part of bracket / flame sensor housing also insulated
- 3 Purge air coupling
- 4 Adjusting ring
- A Flame sensor in adjusting ring with Allen key for M3
- B Adjusting ring with Allen key for M3

Adjustment Bracket with Globe Joint FH80-10.

Technical data

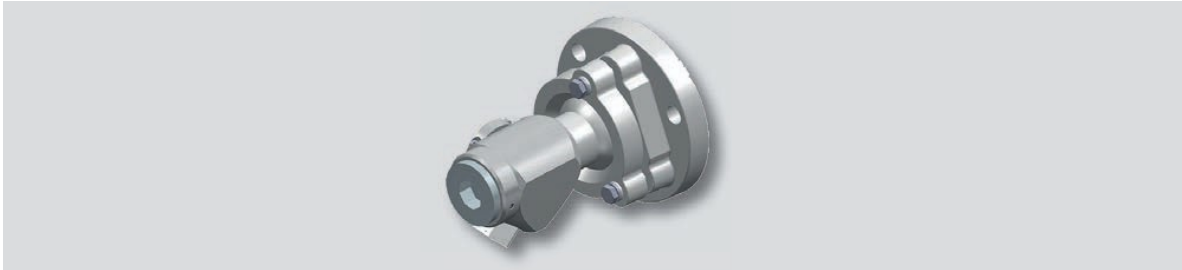

Adjustment Bracket with Globe Joint FH80-10.

Possible applications	FFS08	Dimensions [mm]	l	b	h
Item number	659S2110		Bracket	137	--
Material	Anodised aluminium, plastic	with FFS08	137	171	110
Air connection	Hexagonal nipple G 1/2" i	Weight [kg]	1.35		

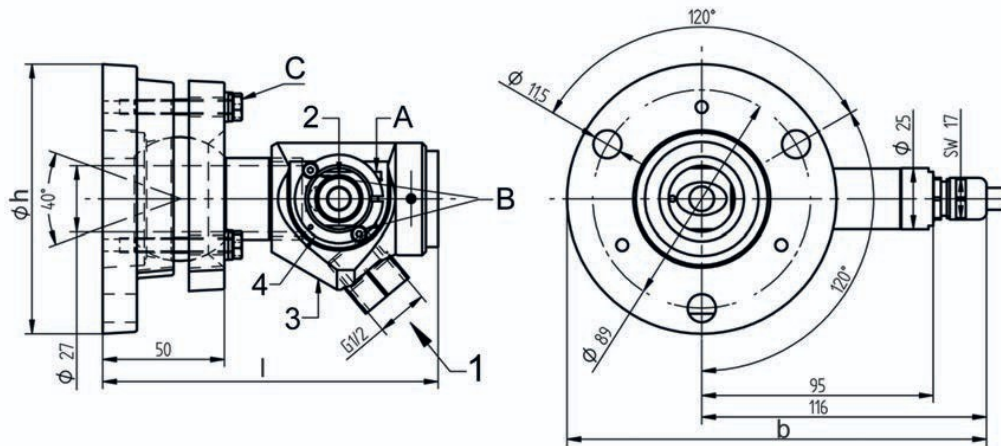

Dimensional drawing FS80-10 with flame sensor FFS06, FFS08

- 1 Purge air
 - 2 Insulating part of bracket / flame sensor housing also insulated
 - 3 Purge air coupling
 - 4 Adjusting ring
- A Flame sensor in adjusting ring with Allen key for M3
 B Adjusting ring with Allen key for M3
 C Locking the globe joint using SW 10.

Bracket with 90° deflecting Mirror FR20-01 as plug-in and threaded Connection Variant.

Technical data



FR20-01 90° deflecting Mirror with F200K

FR20-01 90° deflecting Mirror with FFS07

Possible applications	FFS30, FFS07, FFS07 V, F200K, F200K V, F300K,	Dimensions [mm] Bracket with FFS30/FFS07 with F200K with F300K	l	b	h
			221	--	44
Item number	FR20-01 659V3102 FH60-10 659S1800		308	40	44
Material	Brass, nickel plated Safety glass: Quartz glass		327	80	44
Weight [kg]	0.40				

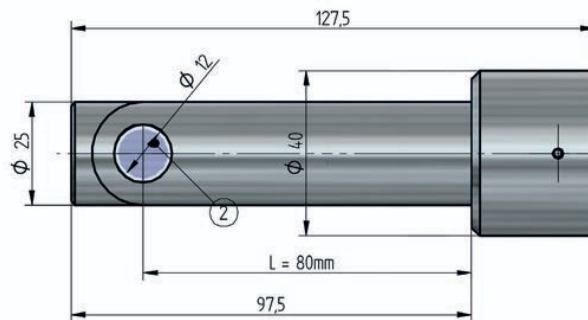

Dimensional drawing Bracket with 90° deflecting Mirror FR20-01

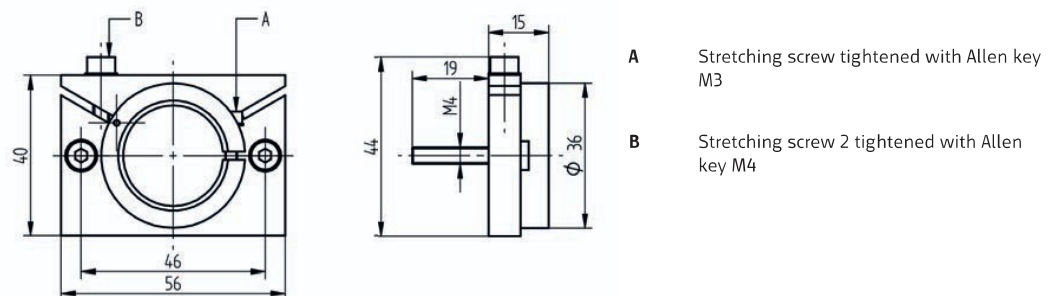

Dimensional drawing Adjustment bracket FH60-10 for direct attachment to the burner

Cooling Air Housing

Cooling air Housing FS30.

Technical data



Cooling air Housing FS30

Possible applications	FFS30, FFS30 Ex, FFS07, FFS07 EX	Dimensions [mm] Bracket with FFS30, FFS07 with FFS30 Ex, FFS07 Ex	l	b	h
Item number	659R0109		168	122	70
Material	Galvanized steel		205	122	70
Air connection	Pipe socket G 1/2" a	Spare parts	215	122	70
Weight [kg]	1.24		659E0107 Sealing washer 659E0109 Threaded connection PG42 with sealing washer		

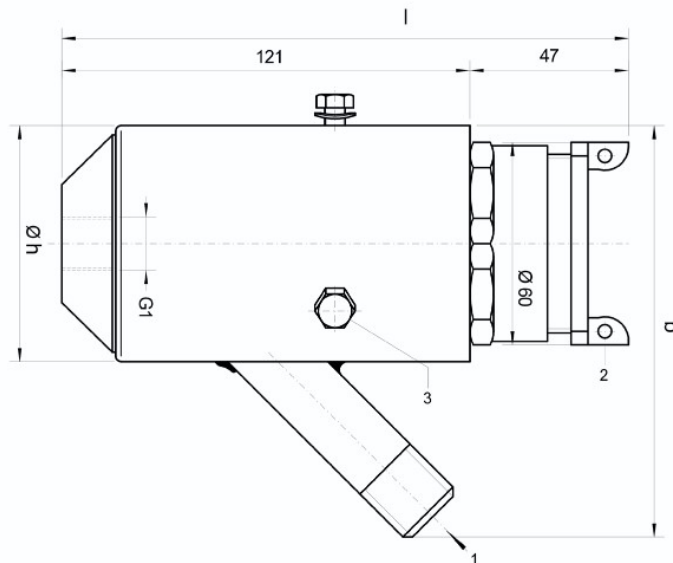

Dimensional drawing cooling air Housing FS30

- 1 Purge air
- 2 Threaded connection PG42 with sealing washer
- 3 Hexagonal stretching screw Polyamide M6 X 16

Cooling air Housing and Globe Joint FS41.

Technical data

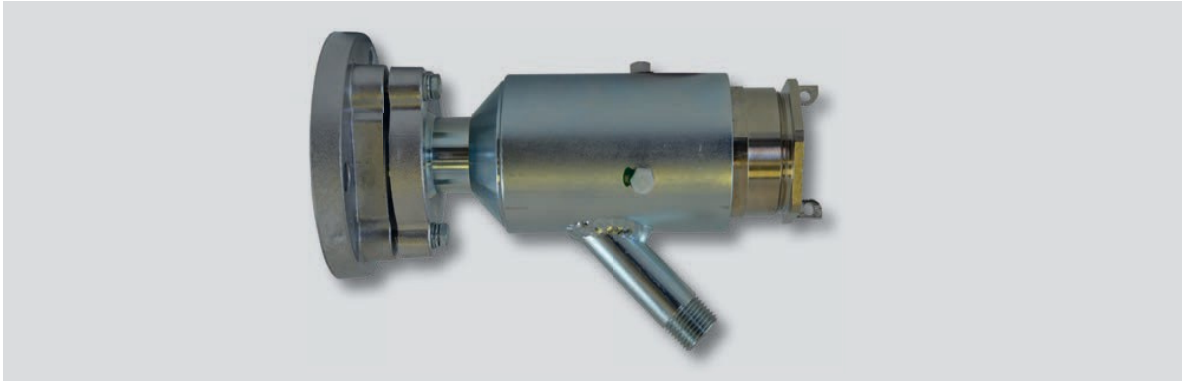

Cooling air housing and globe joint FS41

Possible applications	FFS30, FFS30 Ex, FFS07, FFS07 EX	Dimensions [mm]	l	b	h	
Item number	659R0107		Bracket with FFS30, FFS07	220	--	110
Material	Anodised aluminium, Galvanized steel		with FFS30 Ex, FFS07 Ex	265	40	110
Air connection	Pipe socket G 1/2" a	Spare parts	659E0107 Sealing washer			
Weight [kg]	2.08		659E0109 Threaded connection PG42 with sealing washer			

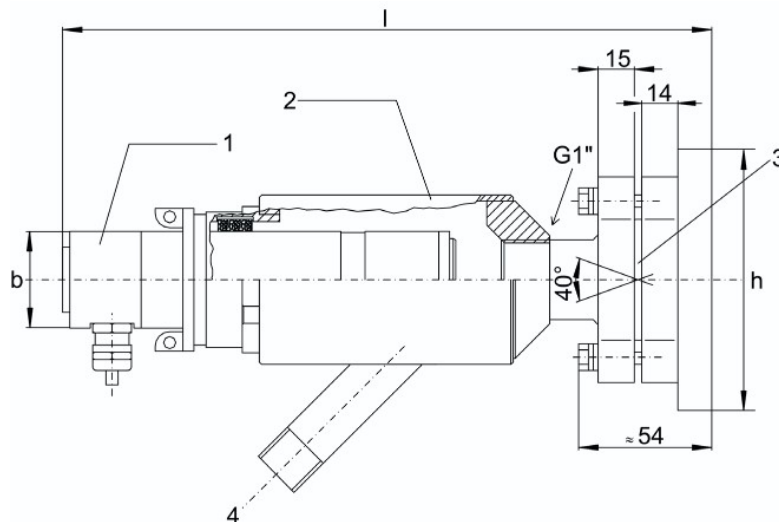

Dimensional drawing FS41 with flame sensor FFS07

- 1 FFS07 Flame Sensor
- 2 Cooling air housing with mounting
- 3 Globe joint
- 4 Purge air connection

Cooling air Housing with Bracket detachable and adjustable FS36.

Technical data

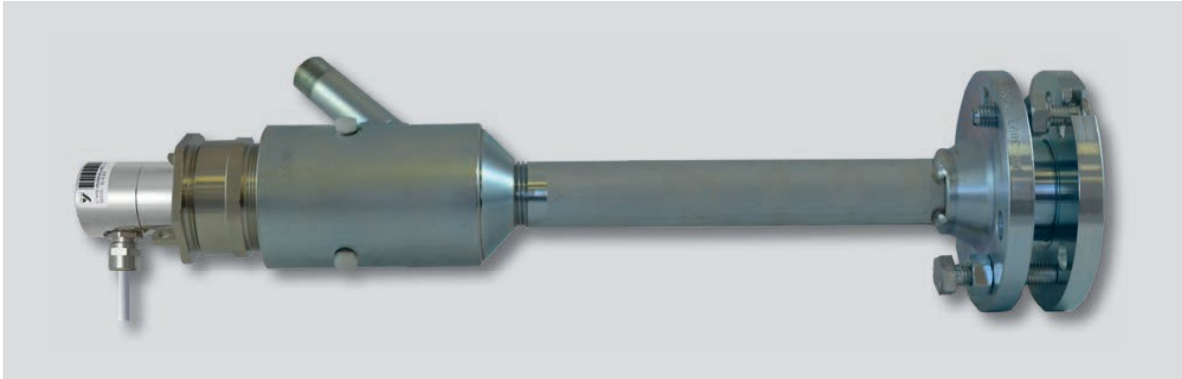

Cooling air housing with bracket detachable and adjustable FS36

Possible applications	FFS30, FFS30 Ex, FFS07, FFS07 EX	Dimensions [mm]	l	b	h
Item number	659R0099		Bracket	420	--
Material	Galvanized steel	with FFS30, FFS07	465	40	120
		with FFS30 Ex, FFS07 EX	475	60	120
Air connection	Pipe socket G 1/2" a	Spare parts	659E0107 Sealing washer		
Weight [kg]	3.24		659E0109 Threaded connection PG42 with sealing washer		
		659R6098 Bracket, detachable			

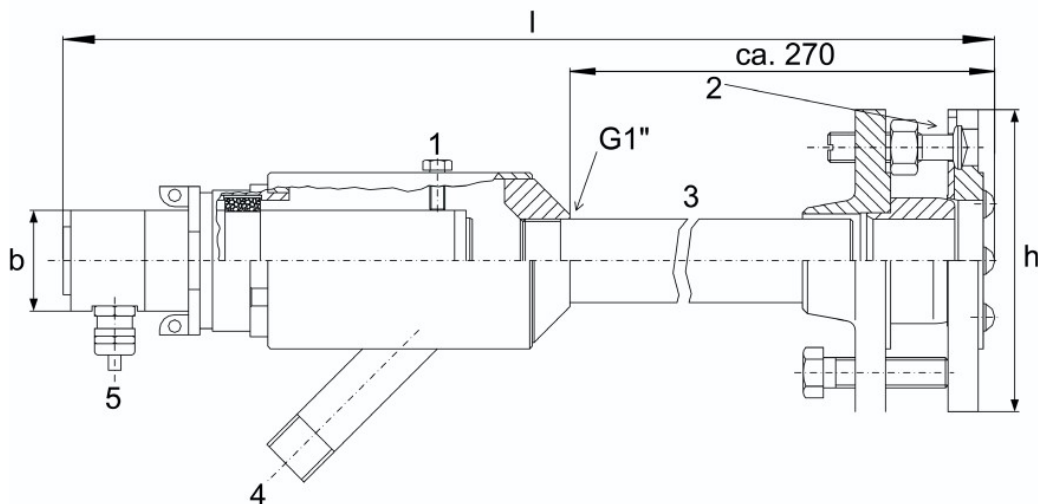

Dimensional drawing FS36 with flame sensor FFS07

- 1 Adjusting screw
- 2 Flange bracket, detachable and adjustable
- 3 Distance sleeve
- 4 Purge air connection
- 5 Flame sensor cable connection

Cooling air Housing FS65.

Technical data

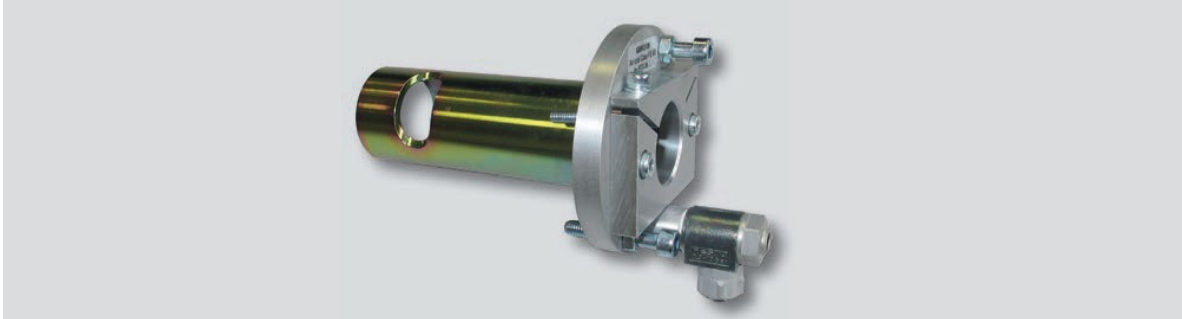

Cooling air housing FS65

Possible applications	FFS08	Dimensions [mm]	l	b	h
Item number	659R3109		Bracket with FFS08	-	34
Material	Anodised aluminium, plastic, galvanized steel		87	34	70
Air connection	GLRZ-1/8-PK6B ($\pm 90^\circ$ pivotable)	Weight [kg]	0.33		

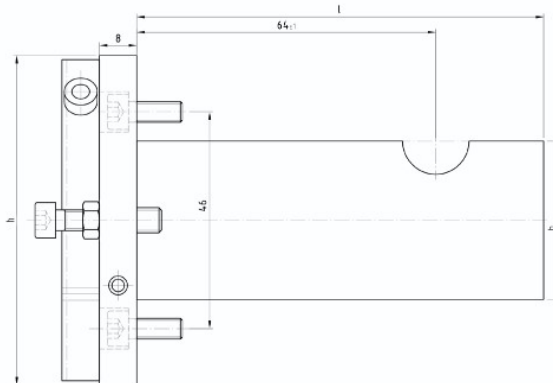

Dimensional drawing FS65 for flame sensor FFS06, FFS08

Performance characteristic Cooling air housing FS65

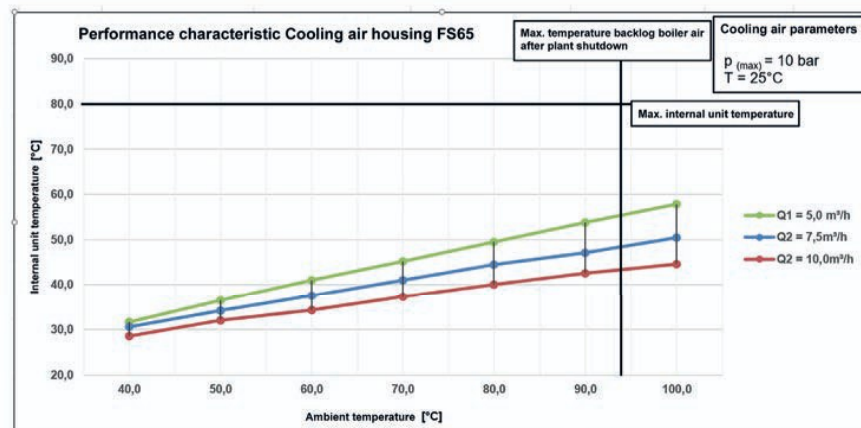

Cooling air Housing FS50.

Technical data

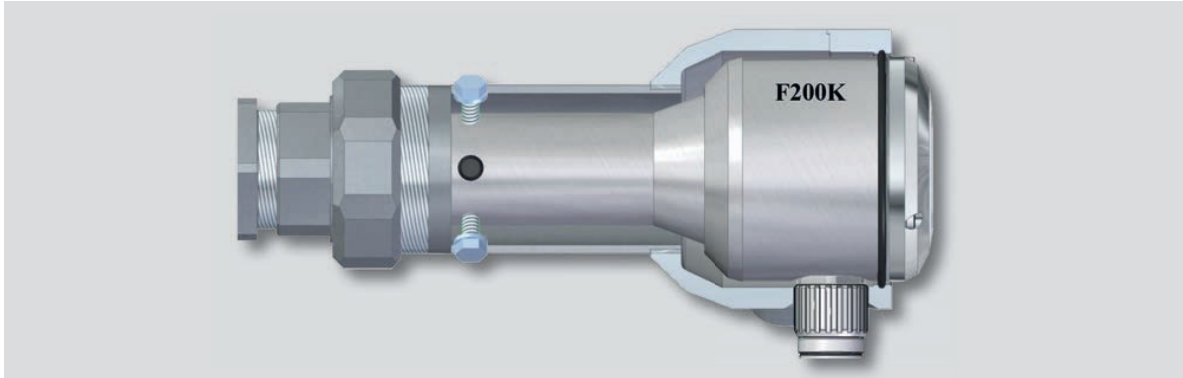

Cooling-air housing FS50

Possible applications	F200K, F200K/V, F200K Ex Zone 2*	Dimensions [mm]	l	b	h
Item number	659R6109		225	100	62
Material	Anodised aluminium Galvanized steel	with F200K	247	100	62
Air connection	Reduction nipple G 1/2" i	Weight [kg]	2.08		

* No cooling air housing for Ex Zone 1.

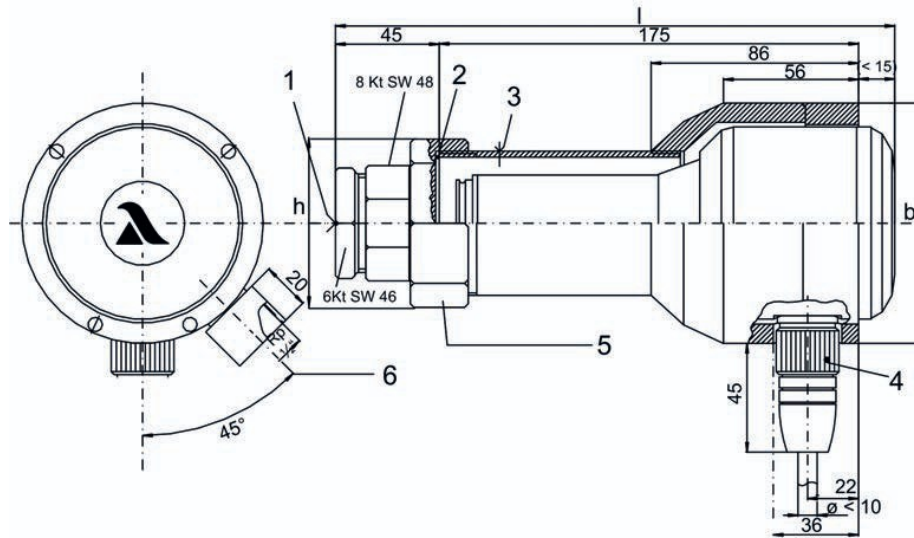

Dimensional drawing FS50 with flame scanner F200K

- 1 Pipe connection (boiler) Rp1"
- 2 Sealing washer 56 x 42 x 2 mm
- 3 3 x Support bolt M6, plastic - insulated installation
- 4 Cable connection with screw cap
- 5 Detachable connection 8 Kt SW 66 (lens cleaning)
- 6 Cooling air connection

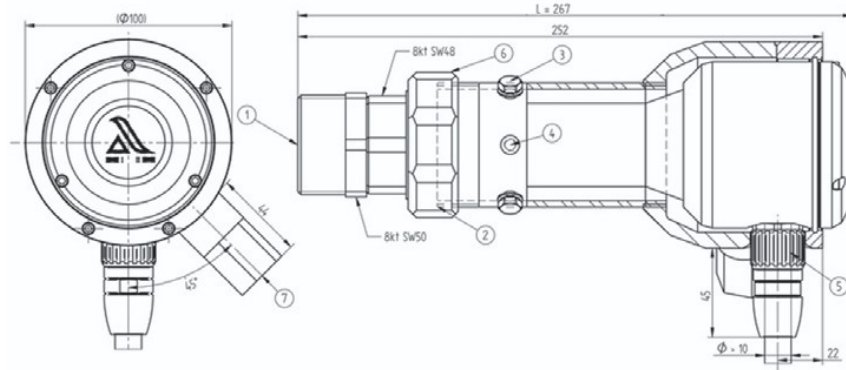

Dimension drawing FS 50-2 cooling air housing with extended air outlet

- | | | | |
|---|--|---|--|
| 1 | Boiler connection G 1 1/2" | 5 | Plug connector with screw cap |
| 2 | Flat seal 56x42x2 | 6 | Detachable connection 8 kt SW 66 (lens cleaning) |
| 3 | 3x Adjusting screw M6 - PP | 7 | Cooling air connection G 1/2" NPT |
| 4 | 3x removable rubber pads (cooling air discharge) | | |

Performance characteristic Cooling air housing FS50

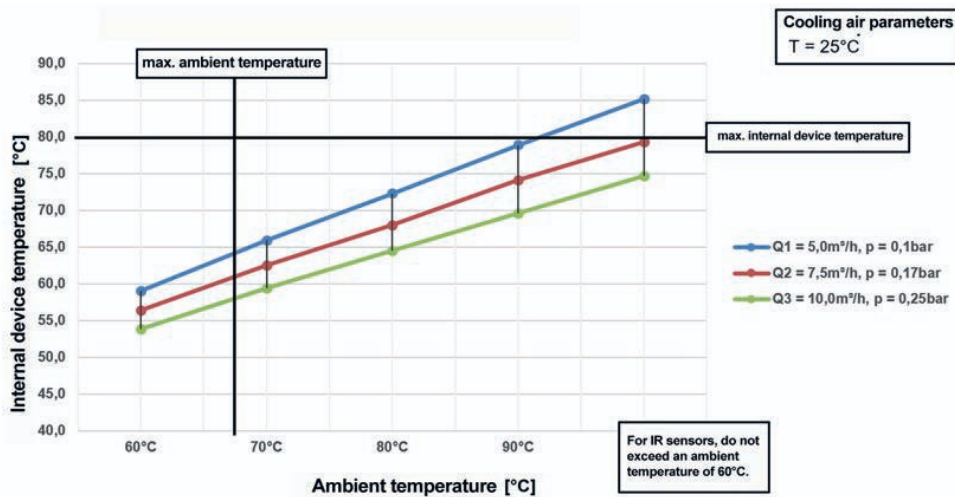

Performance characteristic Cooling air housing FS50

Read-out examples:

- Ambient temperatures up to 55 °C do not require a cooling air housing.
- Starting from 55 °C, cooling is recommended and starting from 60 °C, cooling is mandatory.
- At a cooling air temperature of 15 °C, a volumetric flow of 5 m³/h is sufficient up to 65 °C because an internal operating temperature of 85 °C is not exceeded in the device.
- Up to 70 °C, compressed air is possible with 7.5 m³/h and up to 75 °C in the ambient air, 10 m³/h compressed air can be reached.

Cooling air Housing with Globe Joint FS51.

Technical data

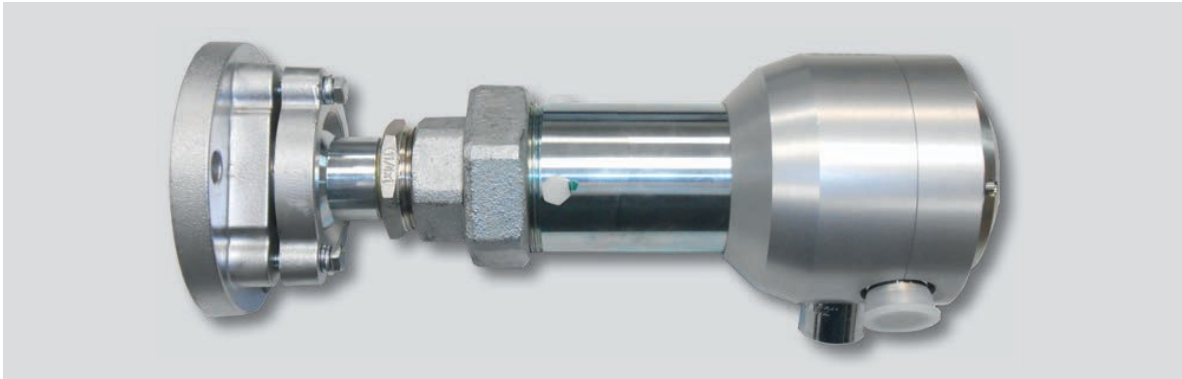

Cooling air housing with globe joint FS51.

Possible applications	F200K	Dimensions [mm]	l	b	h
Item number	659R6107		Bracket with F200K	290	100
Material	Anodised aluminium, Galvanized steel	Weight [kg]	302	100	110
Air connection	Reduction nipple G 1/2" i		2.13		

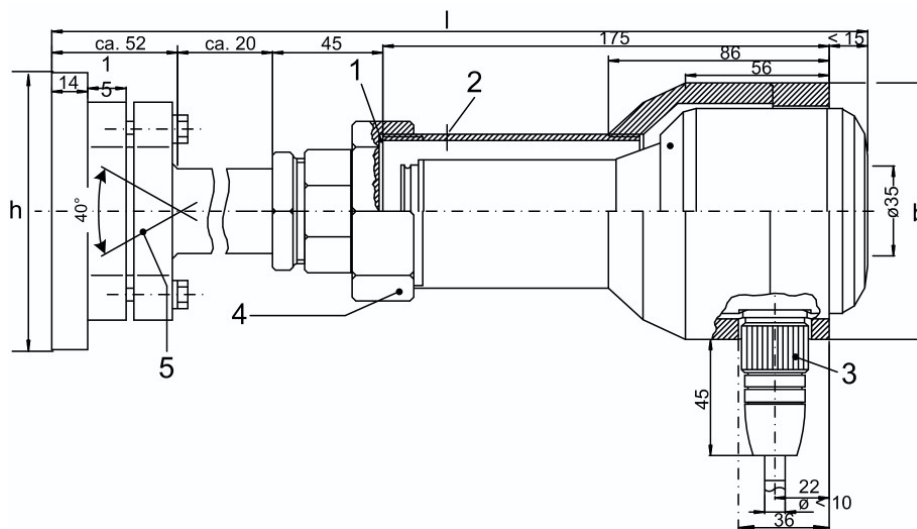

Dimensional drawing FS51 with flame scanner F200K

- 1 Sealing washer 56 x 42 x 2 mm
- 2 3 x Support bolt M6, plastic - insulated installation
- 3 Cable connection with screw cap
- 4 Detachable connection 8 Kt SW 66 (lens cleaning)
- 5 Globe joint

Cooling air Housing with Bracket detachable and adjustable FS56.

Technical data

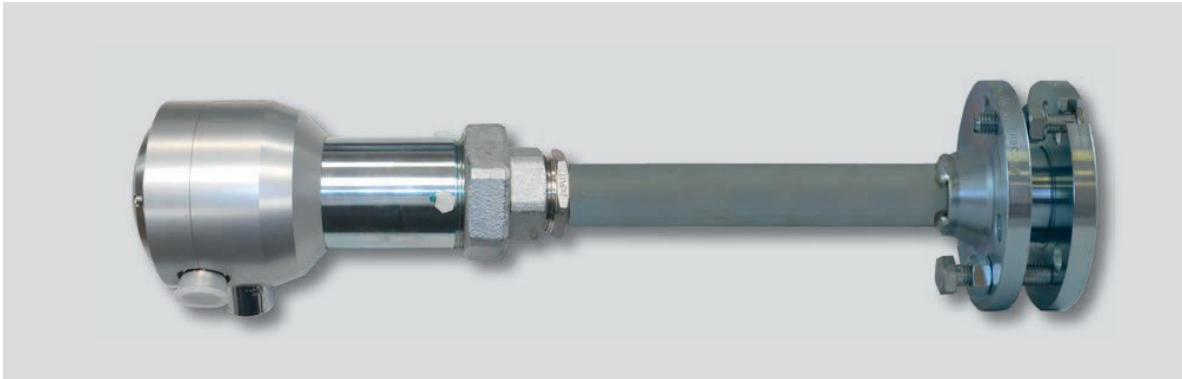

FS56 with flame scanner F200K

Possible applications	F200K	Dimensions [mm]	l	b	h
Item number	659R6099		495	100	120
Material	Anodised aluminium, Galvanized steel	with F200K	507	100	120
		Weight [kg]	1.29		
Air connection	Reduction nipple G 1/2" i	Spare parts	659E0098 Bracket, detachable		

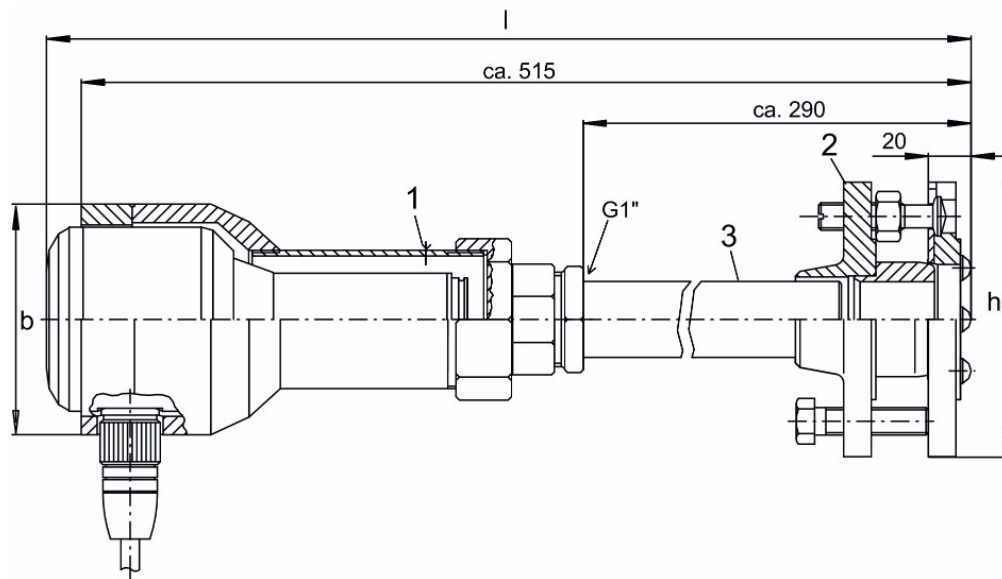

Dimensional drawing FS56 with flame scanner F200K

- 1 3 x Support bolt M6, plastic - insulated installation
- 2 Flange bracket, detachable and adjustable
- 3 Distance sleeve

Cooling air Housing FK30/FK31.

Technical data



Cooling air housing FK30/FK31

Possible applications	F300K	Dimensions [mm]	l	b	h
Item number	659S1100		Bracket with F300K	126	99
Material	Anodised aluminium, plastic	Weight [kg]	0.30		
Air connection	Reduction nipple G 1/2" a Sealing coupling AG Type 26 G1/2"	Spare parts	659ES110 Washers (5 ea.) 659ES111 Locking rings (5 ea.)		

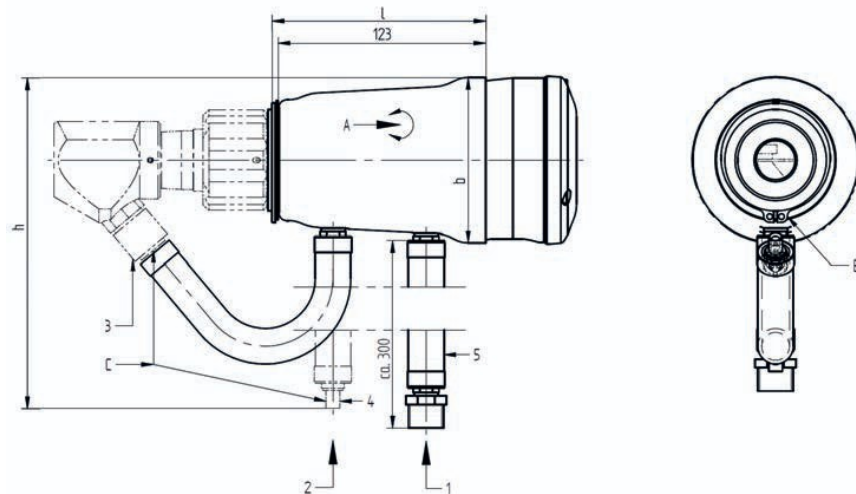

Dimensional drawing FK30/FK31 with flame scanner F300K

- | | |
|--|---|
| <ol style="list-style-type: none"> 1 Supply air with disassembled flame scanner p max. = 0.5 bar 2 Exhaust air/serves as purge air for the ball-and-socket joint FV30-10/FV30-11/FV30-17
Equip bracket with sealing coupling AG Type 26 - G 1/2 (provided)! 3 Sealing coupling 4 Plug socket 5 Flexible connection tube/limit temperatures
-40 °C ... +150 °C | <ol style="list-style-type: none"> A Slide the cooling air housing slightly turning it and applying pressure onto the outer O-rings on the F300K housing. B Lock cooling air housing with washer and locking ring DIN 471 - 60 x 2, using groove in the device optics bracket and locking ring pliers. C Connect and engage sealing coupling and plug socket |
|--|---|

The right to make technical changes is reserved!

Performance characteristic Cooling air Housing FK30/FK31

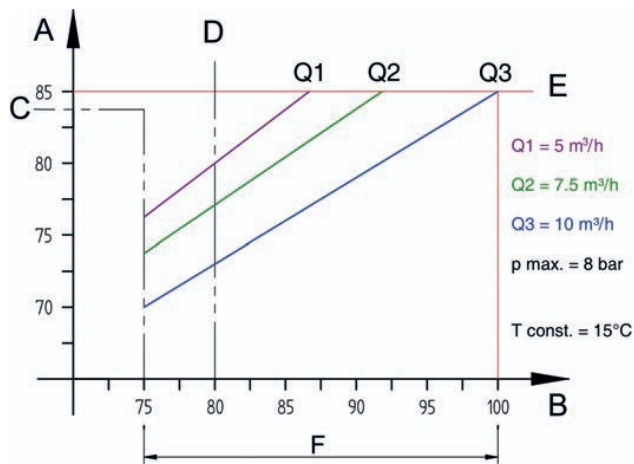

- A = Operating temperature / internal device temperature [°C]
- B = Ambient temperature [°C]
- C = Uncooled range
- D = Limit of cooling requirement
- E = Maximum permissible operating temperature
- F = Application temperature range FK30/FK31

Performance characteristics cooling air housing FK30 at cooling air temperature 15 °C

Read-out examples:

- Ambient temperatures up to 75 °C do not require a cooling air housing.
- Starting from 75 °C, cooling is recommended and starting from 80 °C, cooling is mandatory.
- At a cooling air temperature of 15 °C, a volumetric flow of 5 m³/h is sufficient up to 85 °C because an internal operating temperature of 85 °C is not exceeded in the device.
- Up to 90 °C, compressed air is possible with 7.5 m³/h and up to 100 °C in the ambient air with 10 m³/h.

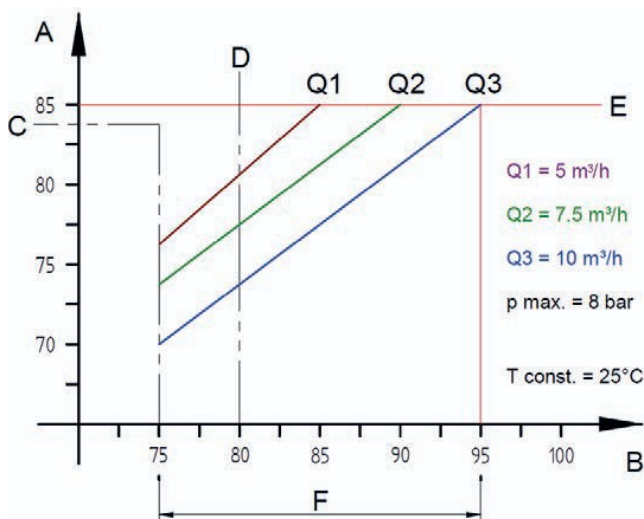

- A = Operating temperature / internal device temperature [°C]
- B = Ambient temperature [°C]
- C = Uncooled range
- D = Limit of cooling requirement
- E = Maximum permissible operating temperature
- F = Application temperature range FK30

Performance characteristics cooling air housing FK30/FK31 at cooling air temperature 25 °C

Read-out examples: see above

Cooling air Housing with Purge Air Coupling and Globe Joint FK41

Technical data

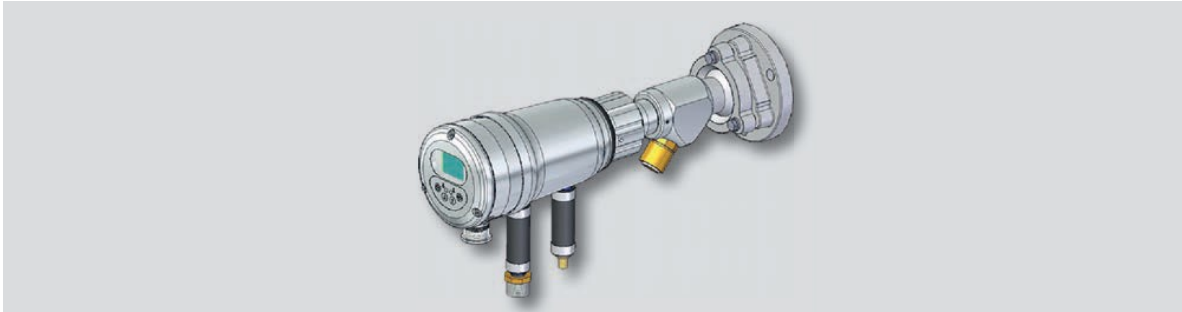

Cooling air Housing with Purge Air Coupling and Globe Joint FK41

Possible applications	F300K	Dimensions [mm]	l	b	h
Item number	659S1401		Bracket with F300K	324	250
Material	Anodised aluminium, plastic	Weight [kg]	1.65		
Connection Supply air Exhaust air	Reduction nipple G 1/2" a Sealing coupling AG Type 26 G1/2"	Spare parts	659ES120 Lock washer socket 659ES110 Washers (5 ea.) 659ES111 Locking rings (5 ea.) 659ES121 O-rings (5 ea.)		

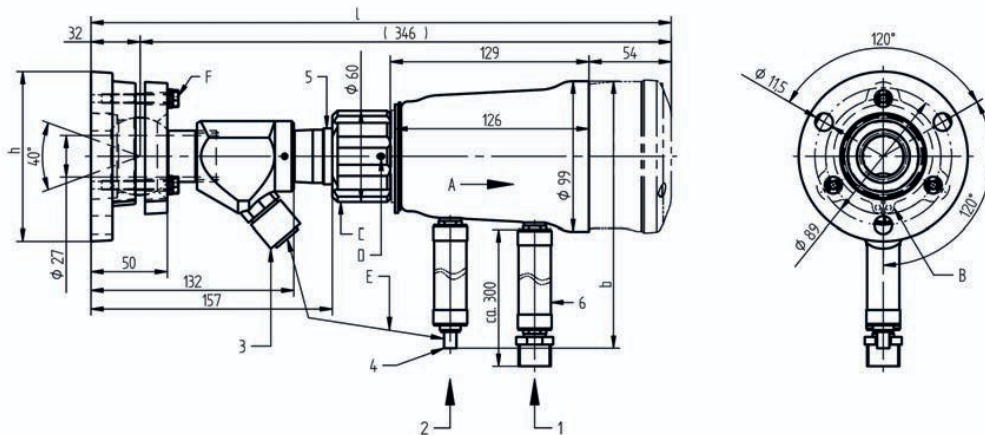

Dimensional drawing FK41 with flame scanner F300K

- | | |
|---|---|
| 1 Supply air | A Slide the cooling air housing slightly turning it onto the outer O-rings on the F300K housing |
| 2 Exhaust air | B Lock cooling air housing with washer and locking ring DIN 471 - 60 x 2 |
| 3 Sealing coupling | C Crown nut tightened by hand and using SW 46 |
| 4 Plug socket | D Locking device tightened with Allen key for M3 |
| 5 Insulating part | E Connect and engage sealing coupling and plug socket |
| 6 Flexible connection tube/limit temperatures
-40 °C ... +150 °C | F Locking the globe joint using SW 10 |

Cooling air Housing with Purge Air Coupling and FS35 - FK46.

Technical data

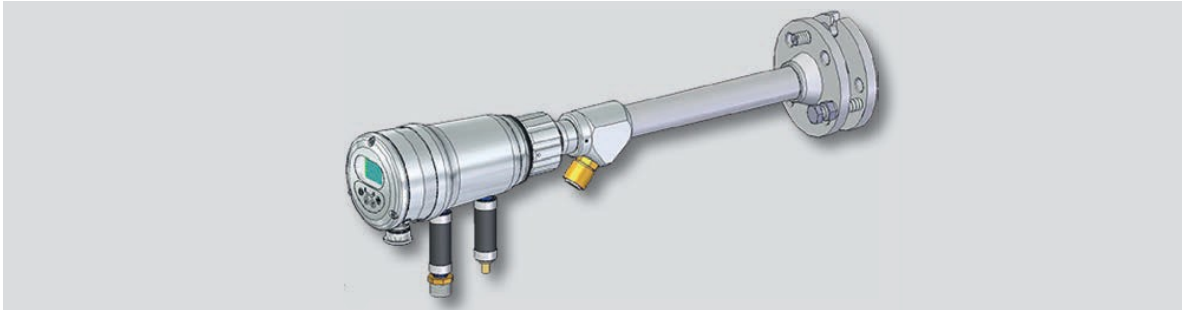

Cooling air Housing with purge air coupling and FS35 - FK46

Possible applications	F300K	Dimensions [mm]	l	b	h
Item number	659S1400		Bracket with F300K	534	250
Material	Anodised aluminium, Galvanized steel, plastic	Weight [kg]	2.80		
Connection Supply air Exhaust air	Reduction nipple G 1/2" a Sealing coupling AG Type 26 G1/2"	Spare parts	659ES120 Lock washer socket 659ES110 Washers (5 ea.) 659ES111 Locking rings (5 ea.) 659ES121 O-rings (5 ea.)		

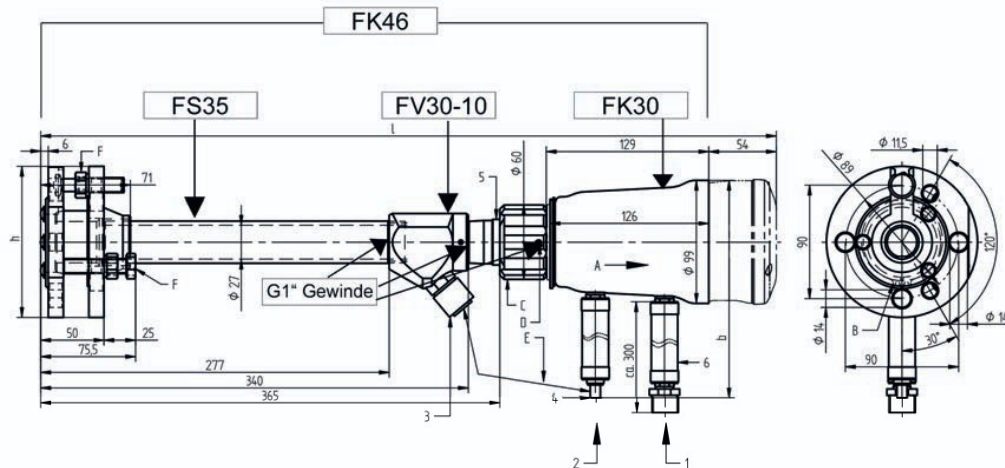

Dimensional drawing FK46 with flame scanner F300K

- | | |
|---|---|
| 1 Supply air | A Slide the cooling air housing slightly turning it onto the outer O-rings on the F300K housing |
| 2 Exhaust air | B Lock cooling air housing with washer and locking ring DIN 471 - 60 x 2 |
| 3 Sealing coupling | C Crown nut tightened by hand and using SW 46 |
| 4 Plug socket | D Locking device tightened with Allen key for M3 |
| 5 Insulating part | E Connect and engage sealing coupling and plug socket |
| 6 Flexible connection tube/limit temperatures
-40 °C ... +150 °C | F Locking the globe joint using SW 19 |

Globe Joint FS10 and FS11 (stainless steel).

Technical data



Globe joint FS10 and FS11 (stainless steel)

Possible applications	FV30 and FH30	Dimensions [mm]	l	b	h
Item number	659E0105 Aluminium 659S0411 Stainless steel		80.5	=G1	110
Material	Anodised aluminium Stainless steel V4A	Weight [kg]	0.85 Aluminium 1.93 Stainless steel		

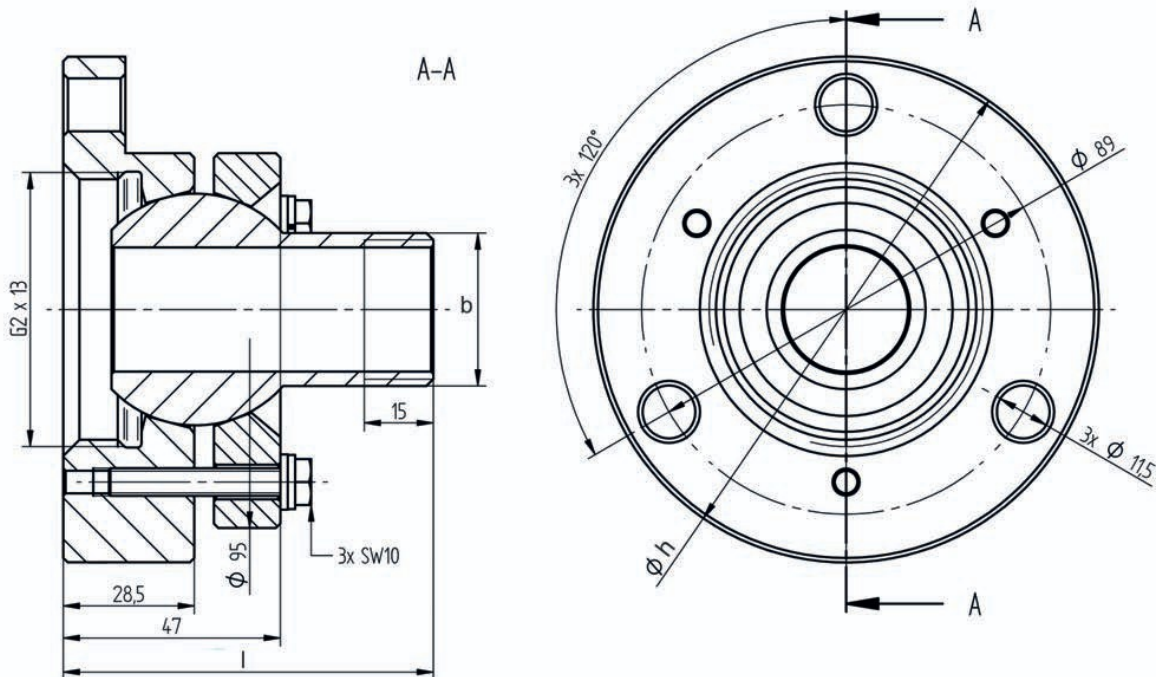

Dimensional drawing globe joint FS10/FS11

Welding Neck Flange FS1x in V4A and V2A.

Technical data



Welding neck flange FS1x in V4A and V2A

Possible applications	V2A with FS10 V4A with FS11	Dimensions [mm]	See dimensional drawing
Item number	659S3101 V4A 659S3102 V2A		
Material	Stainless steel V4A and/or V2A	Weight [kg]	0.96

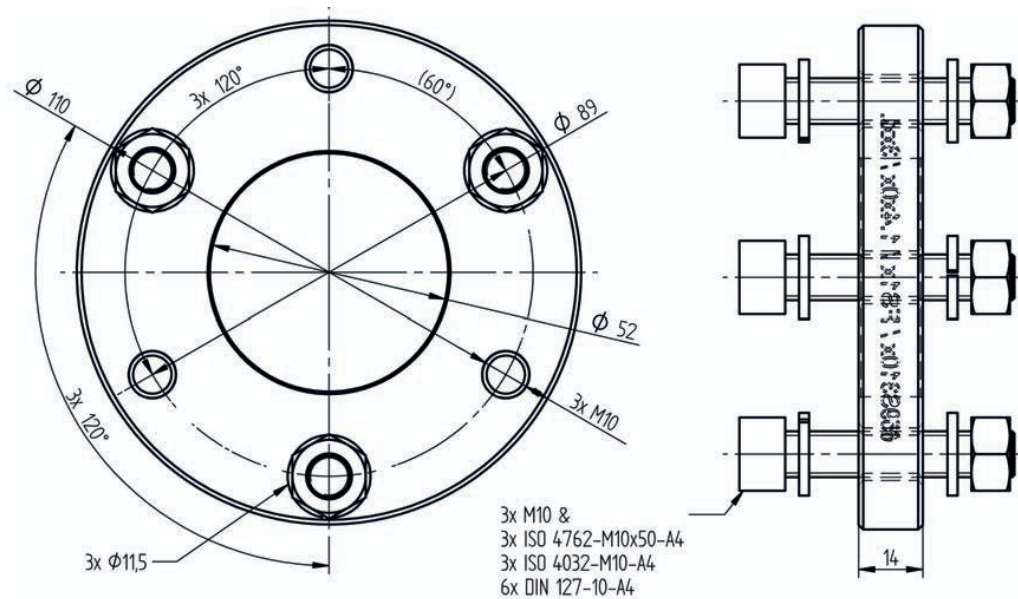

Dimensional drawing Welding neck flange FS1x in V4A and V2A

Insulation Part for Flame Scanner Brackets.

Technical data

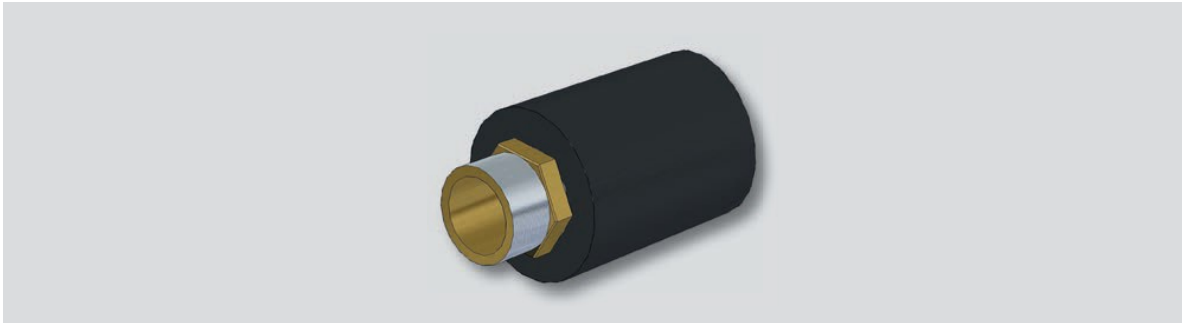

Insulation part for Flame Scanner Holding Device

Possible applications	For thermal decoupling of flame scanners F300K, F200K, FFS30 and FFS07	Dimensions [mm]	l	b	d
Item number	659S3900		70	--	60
Material	Brass, plastic (PPS)				
Connection	G1"IG / G1"AG	Weight [kg]	0.3		

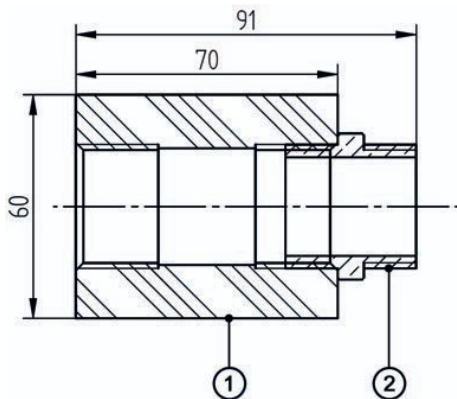

Dimensional drawing Insulation part

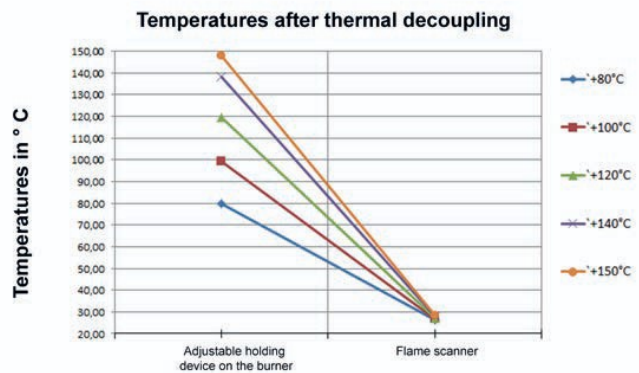

Temperatures after thermal decoupling

- 1 Insulating piece G1"IG / G1"IG
- 2 Double nipple DN25, 1"G-AG / 1"G-AG, brass

Vibration Decoupler.

Technical data

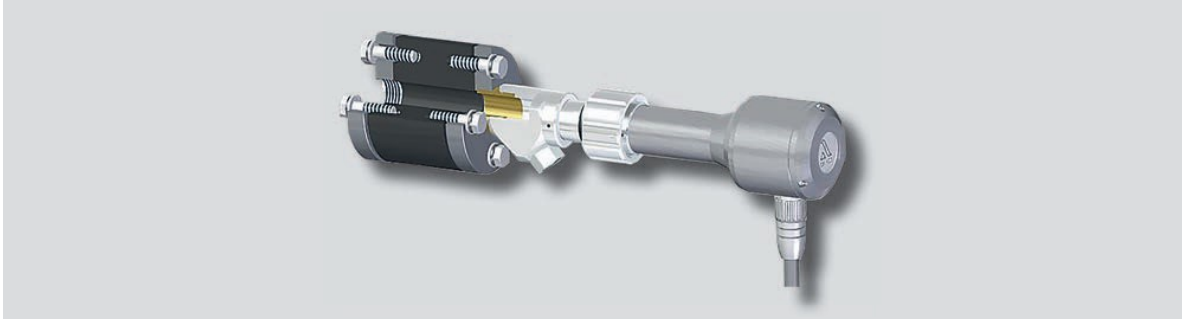

Vibration Decoupler

Possible applications	Decoupling vibrations from the combustion chamber	Dimensions [mm]	See dimensional drawing
Item number	659S3800	Weight [kg]	4.07

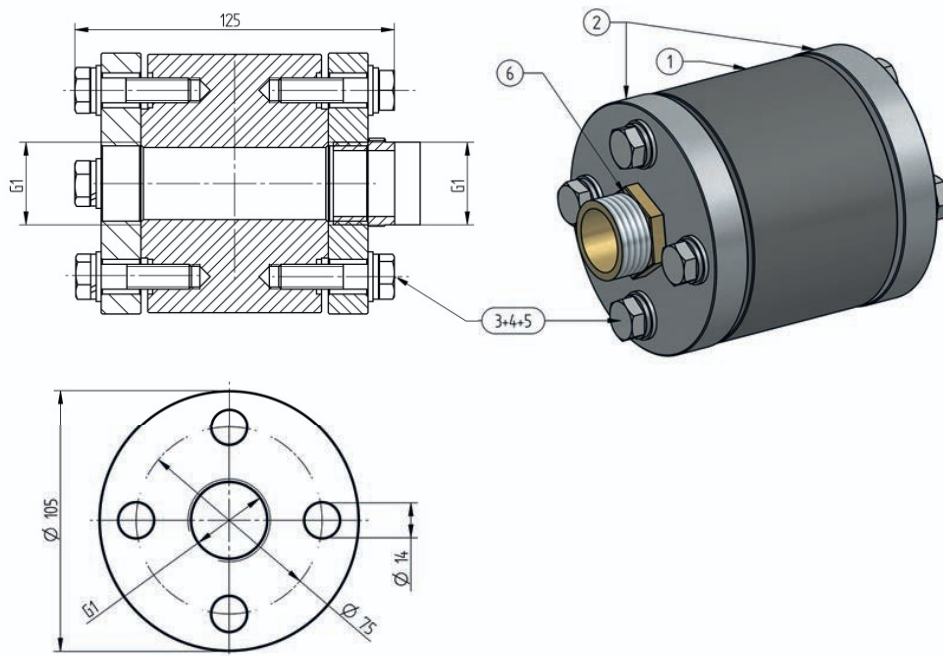

Dimensional drawing Vibration Decoupler

- 1 Rubber-metal pipe connector GRV, DN25, PN6
- 2 VA blind flange G1" - IG, DN20, PN16
- 3 M10x40, DIN 933 6-kt screw with thread, A2
- 4 Spring washer 10/7 V4A, DIN127 - 10 - A4
- 5 Washer M10, DIN125 Form A, A2
- 6 Double nipple DN25, 1"G-AG / 1"G-AG, brass - L nipple: 35 mm; L thread:14 mm

Shut-off Unit.

Technical data



Shut-off unit

Possible applications	Simulation flame-out	Dimensions [mm]	See dimensional drawing
Item number	659R5008		
Version	Stainless steel ball valve 1" AG/IG with wing grip, PN64	Weight [kg]	0.76

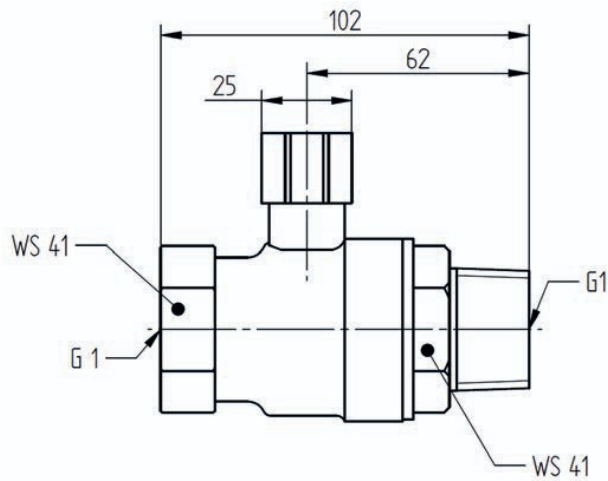

Dimensional drawing Shut-off unit

Serves, among other things, to separate the flame sensor from the combustion chamber when changing the appliance. The holders have a blocking disc and therefore do not require any extra separation at an overpressure of up to 0.5 bar, except in the event that the blocking disc has to be cleaned during operation! The blocking disc has to be cleaned during operation!

Simulation terminal ionisation.

Technical data



2-level terminal ionisation block

Possible applications	Translation of the digital signal FLAME OFF/ON to an ionisation current	Dimensions [mm]	See dimensional drawing
Item number	660R3000	Width	6.2 mm
Material	Insulating material PA	Connection type	Screwed connection
Installation type	Mounting rail 35/7.5	Cross-section	0.2 mm ² ... 4 mm ²

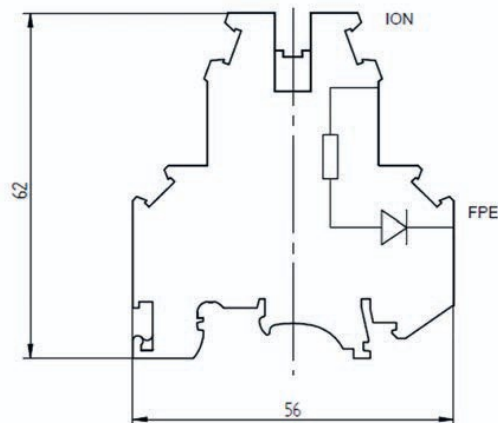

Dimensional drawing 2-level terminal ionisation block

Connecting Cable Protective Tube.

Technical data

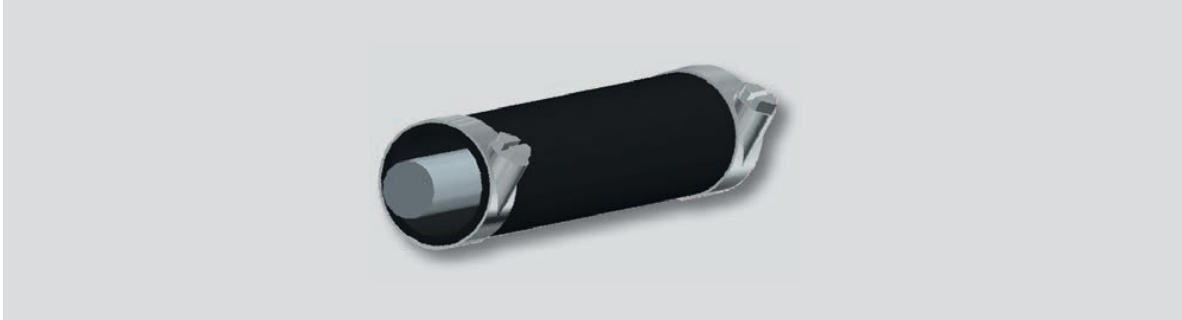

Protective tube for cables

Possible applications	For the protection of the LAMTEC standard and silicone cables F300K, F200K	Dimensions	d	l
			18/21 mm	3/5/10 m
Item number	659N9900 Length 3 m 659N9901 Length 5 m 659N9902 Length 10 m	Properties	UV resistant, Ozone resistant, Weatherproof, Temperature resistant -35 °C to +100 °C	
Material	Inner hose: Bright gummed cord fabric Outer sleeve: SBR rubber, black		Connection	Stainless steel hose clamp

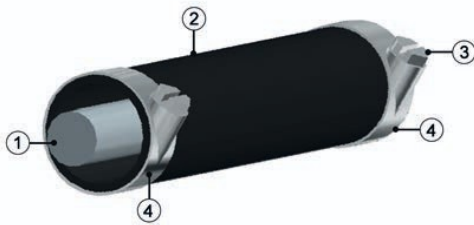

Protective tube details

- 1 LAMTEC standard and silicone cables. Depending on the cable diameter, pull the correct heat-shrinkable sleeve over the cable ends!
- 2 Cable protection conduit / outer Ø 21mm
- 3 Wrench size 7
- 4 Hose clamp, press protruding metal strip against hose clamp!

Heated Thermal Jacket for F200K.

Technical data



Heated Thermal Jacket

Possible applications	With the heated thermal jacket, the F200K can be operated up to an ambient temperature T min of -55°C. The ambient temperature T max drops to +50 °C.	Closure type	Velcro/brushed wool
		Material	Surface coated with PTFE, antistatic. 1-part, moisture-protected, glass fabric with 20 mm non-woven material filling
Item number	659S400..		

Order information

Thermal jackets	Selection
Heated thermal jacket, 230 VAC, for series F200K IV, F200K Ex-II IV, for ambient temperatures up to -55 °C, consisting of thermal jacket, heating band carrier with junction box, Ex T5, temperature monitoring not required	659S4000
Heated thermal jacket, for 120 VAC, for series F200KIV, F200K Ex-II IV,	659S4001
Heated thermal jacket, 230 VAC, for series F200K Ex for ambient temperatures up to -55 °C, installation consisting of thermal jacket, heating band carrier with junction box, Ex T5, obligatory temperature monitoring separately	659S4002
Heated thermal jacket, for 120 VAC, for series F200K Ex	659S4003
Fitting hose clamp V2A for fastening the temperature sensor to the F200K housing	659S4012
Safety temperature monitor -55 °C/+40 °C	659S4014

Weather Protection for F200K and F200K-Ex.

Technical data



Weather Protection for F200K and F200K-Ex

Possible applications	For protection from weather and environmental influences for F200K and F200K-Ex	Dimensions	See dimensional drawing
Item number	659R6030 659R6030/Ex	Properties	Weatherproof and Corrosion-resistant
Material	Stainless steel	Fastening	Stainless steel hose clamp

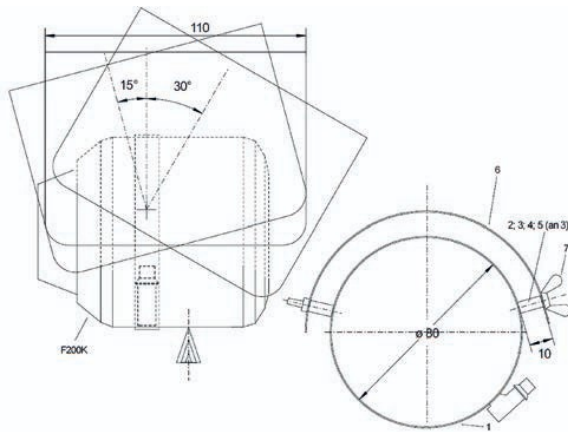

Dimensional drawing weather protection FW 01 for F200K

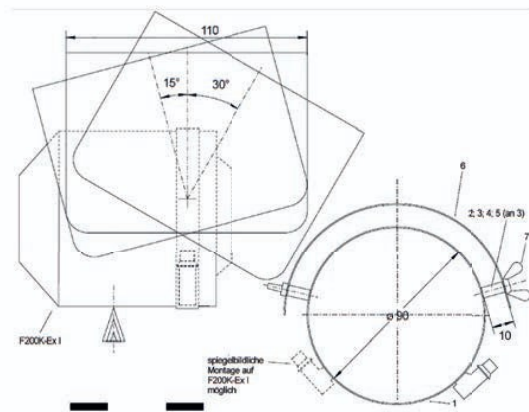

Dimensional drawing weather protection FW 02 for F200K-Ex I

Flame-Scanner Testing Device FFP30.

Technical data



Flame Scanner Testing Device FFP30

Application	Flame simulation for IR and UV flame sensors	Dimensions [mm]	See dimensional drawing
Item number	659M5000	Material	Anodised aluminium
Supply voltage	Battery 9 V, 500 mAh autom. Shut-down after approx. 5 min	Weight [kg]	0.52
Frequency range	Flame simulation in 4 changing frequency ranges	Battery life	Approx. 3 years
		Ambient temperature	-10 ... +60 °C
Mounting	Screw connection for F200K, F300K, FFS30 Plug-in connection for FFS07, FFS08.		

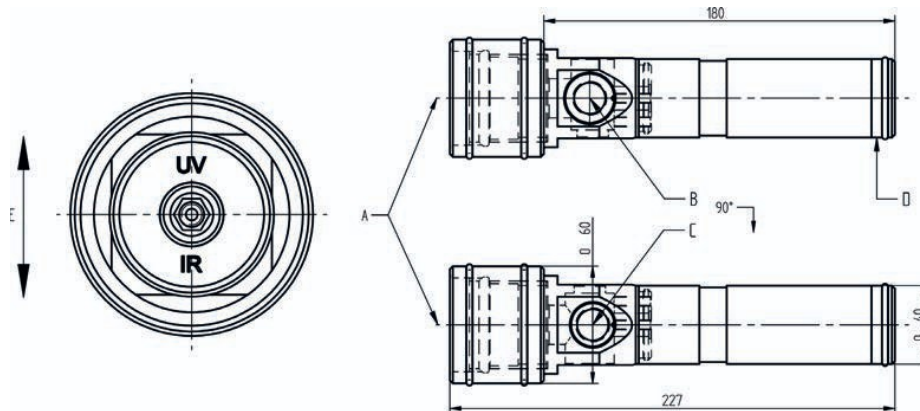

Dimensional drawing Flame Scanner Testing Device FFP30

- A, B, C** Screw connection for F200K, F300K, FFS30
Plug-in connection for FFS07, FFS08
- D** Battery change (9 V, 500 mA - Opening by turning to the left)
- E** Toggle switch

Power Supplies for Flame Scanners.

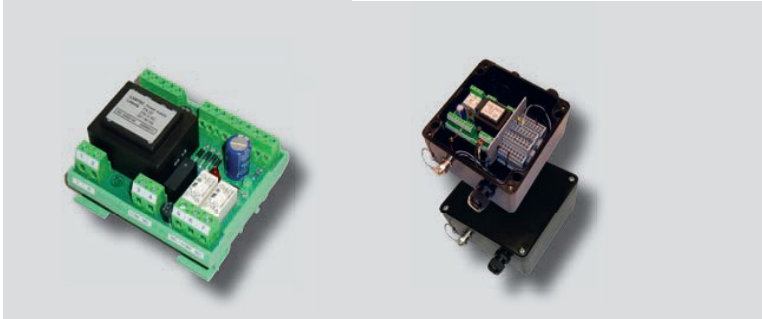

Power supply FN20 659R6010 230 V

Power supply FN30-20 659M0402 230 V

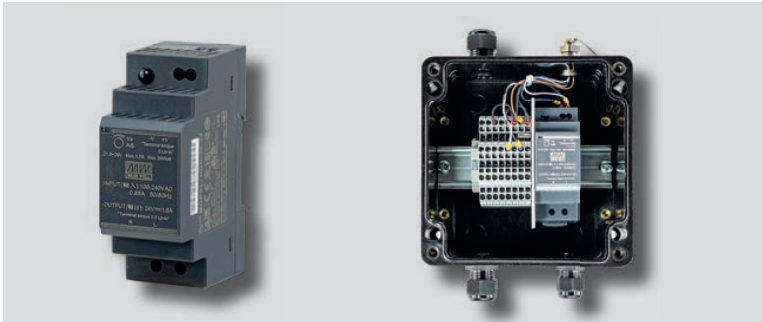

Power supply FN30-00 659M0400 100 ... 240 V

Power supply FN30-10 659M0401 100 ... 240 V

Order information

Designation/type	Input voltage	Protection class	Use for	Selection
Power supply FN20 with relay output for din rail mounting	230 V	IP20	F200K/F300K	659R6010
Power supply FN20 with relay output for din rail mounting	115 V	IP20	F200K/F300K	659R6010/115
Power supply FN30-00 For din rail mounting	100 ... 240 V	IP20	F300K	659M0400
Power supply FN30-10 in polyester housing	100 ... 240 V	IP66	F300K	659M0401
Power supply FN30-20 consisting of FN20 + FN30-20 in polyester housing	230 V	IP66	F200K/F300K	659M0402
Power supply FN30-20 in polyester housing	115 V	IP66	F200K/F300K	659M0403

Junction Box for Flame Scanner FFS07, FFS08, F200K.



Junction box FG21 659N5100

Junction box FG24 Ex 659R0111

Designation/type	Protection class	Use for	Selection
Junction box FG21, aluminium	IP65	F200K, FFS07 and FFS08	659N5100
Junction box FG24 Ex, polyester	IP66	F200K and FFS07	659R0111

Junction Box for Flame Scanner F300K.



FG30-00

FG30-20

FG30-21-V4A

Designation/type	Protection class	Selection
Junction box FG30-00, plastic	IP65	659N5500
Junction box FG30-20, plastic	IP66	659N5502
Junction box FG30-21-V4A, stainless steel	IP66	659N5504

Flamescanner Remote Software.

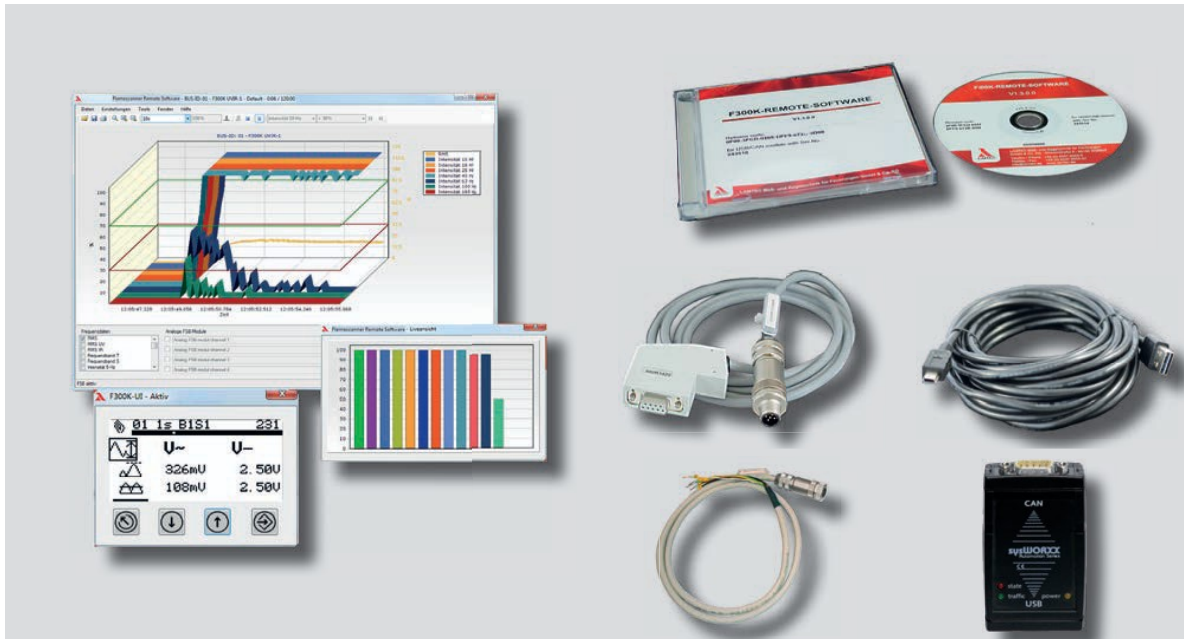

Flamescanner Remote Software

The flamescanner remote software is used to record and a graphic display of flame data chronologically recorded by the F300K / F350. This data can be analysed and optimal settings for the flame scanner can subsequently be determined. Additionally, the software of the user interface (UI) of the F300K UI and/or the FB30 is integrated, which allows for the identical operation and parameter setting of the F300K / F350.

- Connection to the PC via FSB/USB module and adapter cables.
- The flamescanner remote software allows you to set all parameters. In addition, it also offers analysis, data backup and recording functions.
- In addition to the flame scanner data, you can also connect up and record external, analogue and/or digital data by means of FSB modules. All of the data is synchronised.
- The data is exchanged via FSB (FLAME SCANNER SYSTEM BUS).
- Compatible with F300K and FFS30

FSB gateway

- An interface to the control technology can be implemented via the FSB gateway.
- Data from one or from up to 32 F300K devices can easily be sent via a control technology field bus.

FSB gateway is available for the following field buses:

- PROFIBUS (Slave)
- MODBUS TCP (Client/Server)
- MODBUS RTU (Master/Slave)
- Ethernet (Frame)
- CANopen



FSB-Gateway

Repeater

- One repeater is required for a total FSB line length of over 80 m.
- Via the use of multiple repeaters, up to 32 flame scanners with a line length of several 100 m can be coupled via a bus system.



Repeater

Example for networking

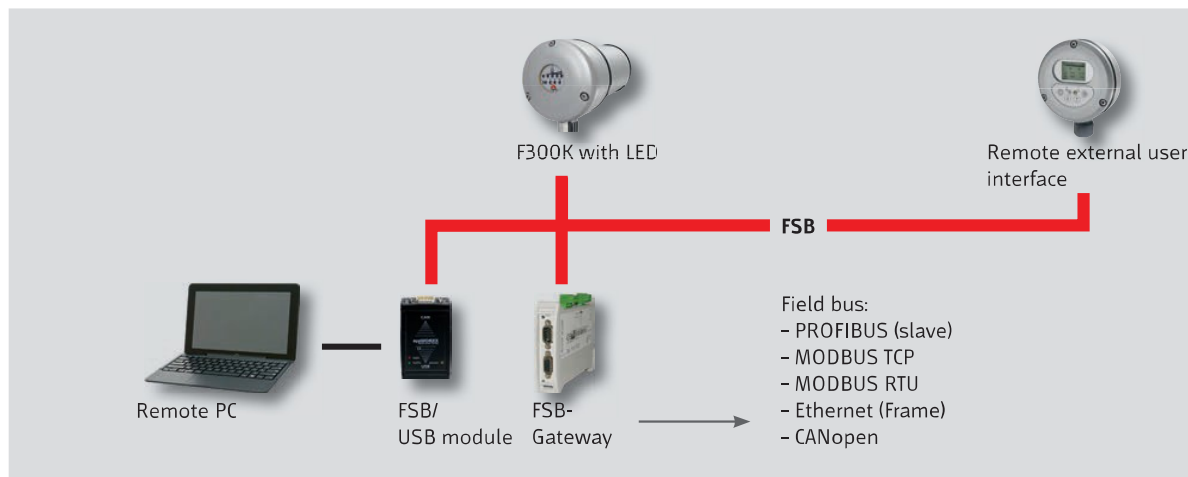

Example: Networking with an F300K.

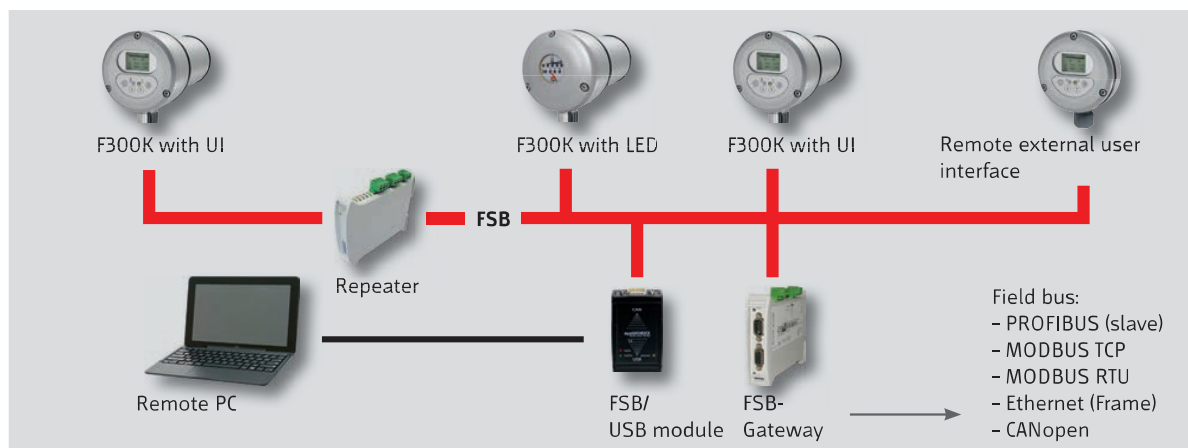

Example: Networking of multiple F300Ks.

Designation/type		Selection
Flame scanner remote software		659R9000
FSB Gateway Modbus TCP Slave		659M3001
FSB Gateway Modbus RTU Slave		659M3002
Repeater		659M3005

Optics Holders and Lenses for Flame Sensors.



Optics Holders and Lenses for FFS05-UV_V and F200K

Order information

Designation/type	Selection
Optics holder with lens (biconvex) for FFS05-UV and F200K...UV up to serial no.: 82900999	659E2001
Optics holder with lens (biconvex) for FFS05-UV/V and F200K...UV/V up to serial no.: 82900999	659E2001/V
Optics holder with lens (biconvex) for FFS05-UV/EX2 and F200K...UV/EX2 up to serial no.: 82900999	659E2001/Z2
Optics holder with filter disc for FFS05-IR and F200K...IR	659E1001
Optics holder with filter disc for FFS05-IR /V and F200K...IR /V	659E1001/V
Optics holder with filter disc for FFS05-IR/EX2 and F200K...IR/EX2	659E1001/Z2
Optics holder with lens (plano-convex) for FFS07-UV and F200K...UV from serial no.: 82902000	659EV402
Optics holder with lens (plano-convex) for FFS07-UV /V and F200K...UV /V and Ex-II/V from serial no.: 82902000	659EV404
Optics holder with filter disc for FFS07-IR	659EV401
Optics holder with filter disc for FFS07-IR /V	659EV403
O-ring for optics FFS05 / FFS07 / F200K (5 ea. per package)	659E1000

The ... /V optics holders are conductively bonded with the 200K housing. This results in that it is difficult to loosen the optics holders from the housing and sometimes not possible without damage. When mounting a new optics holder, make sure that it is conductively bonded with the F200K housing again.

Spare Parts.



Lock washer quartz glass

Lock washer socket incl. lock washer
for FS19-10, FS20-10, FH 30-10, FH40-10Lock washer socket incl. lock washer
for brackets FV30 and FV40

O-Ring 27.5 x1 mm



Cover for F200K with flat disc and screws



O-ring for F200K Ex1

Welded spare bracket for
FH30-10, FH40-10 without insulating part

Designation/type	Selection
Lock washer quartz glass	659E0102
Lock washer socket incl. lock washer for FS19-10, FS20-10, FH30-10, FH40-10.	659ES150
Lock washer socket incl. lock washer for brackets FV30 and FV40	659ES120
O-ring 27.5 x1 mm	659ES121
Cover for F200K with flat disc and screws	659E6001
O-ring for F200K Ex1	F200KEX0015/OR
Welded spare bracket for FH30-10, FH40-10 without insulating part	659ES151

Discontinued item.

Designation/type	Selection
Flame Monitoring Device F250	
Flame monitoring device F250 (24 VDC), 50 Hz, output 4...20 mA, without housing	659R0000
Flame monitoring device F250 (24 VDC), 60 Hz, output 4...20 mA, without housing	659R0000/60HZ
Flame monitoring device F250 (24 VDC), 50 Hz, output 4...20 mA, standard	659R0001
Flame monitoring device F250 (24 VDC), 60 Hz, output 4...20 mA	659R0001/60HZ
Flame monitoring device F250 (24 VDC), 50 Hz, output 0...20 mA, standard	659R0001/0..20MA
Power supply FN01 230 VAC / 24 VDC	659R0010
Power supply FN01 115 VAC / 24 VDC	659R0010/115
Assembly carrier 20 TE	659R0011
Panel housing 16 TE	659R0012
Panel housing 20 TE	659R0013
Wall mounting housing 20 TE	659R0014
Flame Monitoring Device F150	
Flame monitoring device F150 - 1 sec. 230 VAC / 50 Hz, Standard	659R0002
Flame monitoring device F150 - 1 sec. 230 VAC / 60 Hz	659R0002/60HZ
Flame monitoring device F150 - 1 sec. 115 VAC / 50 Hz	659R0002/115
Flame monitoring device F150 - 1 sec. 115 VAC / 60 Hz	659R0002/115/ 60HZ
Plug-in card carrier SKT16	659R0021
Wall mounting housing 12 TE	659R0024

Discontinued item.

Designation/type	Selection
Flame sensor FFS05, axial light entry opening, for flame monitoring device F150, F250 and ETAMATIC	659R ...
A 10 - "SPECTRUM"	
TYPE UV-1 UV SPECTRAL REGION 260...400 nm	2001
TYPE UV-2 UV SPECTRAL REGION 210...380 nm	2002
TYPE UV-3 UV SPECTRAL REGION 210...380 nm for high selectivity	2003
TYPE IR-1 IR SPECTRAL REGION 1,200...2,800 nm recommended for F150 und F250	1001
TYPE IR-1 T IR SPECTRAL REGION 1,200...2,800 nm for low flame frequencies, recommended for ETAMATIC	1001T
TYPE IR-2 IR SPECTRAL REGION 850...1,200 nm for combustion chamber monitoring	1002
A 20 - "HOUSING"	
STANDARD HOUSING Fitting ball-and-socket joint FH30-00, FH30-10, FH40-10	0
HOUSING WITH SCREW FASTENING Fitting ball-and-socket joint FV30-00, FV30-10, FV40-10	V
HOUSING IR-1 FOR Ex-ZONE 1 (II2 G/D EEx-de-IIC T6) Fitting ball-and-socket joint FH30-25, FH40-25	Z1 IR
HOUSING UV FOR Ex-ZONE 1 (II2 G/D EEx-de-IIC T6) Fitting ball-and-socket joint FH30-25, FH40-25	Z1 UV
HOUSING FOR Ex-ZONE 2 (II3 G EEx-nA-II T6) Fitting ball-and-socket joint FH30-00, FH30-10, FH40-10	Z2
HOUSING FOR Ex-ZONE 2 WITH SCREW FASTENING (II3 G EEx-nA-II T6) Fitting ball-and-socket joint FV30-00, FV30-10, FV40-10	Z2/V
A 30 - "CABLE LENGTH"	
CONNECTING CABLE, Length 10 m	10
CONNECTING CABLE (SILICONE), Length 10 m, not for Ex1	10/Si
CONNECTING CABLE, Length 3 m	3
CONNECTING CABLE (SILICONE), Length 3 m, not for Ex1	3/Si
CONNECTING CABLE, Length 5 m	5
CONNECTING CABLE (SILICONE), Length 5 m, not for Ex1	5/Si
CONNECTING CABLE, Length 0.3 m, only available with plug	OE
CONNECTING CABLE (SILICONE), Length 0.3 m, only available with plug, not for Ex1	OE/Si
A 40 - "PLUG"	
WITHOUT PLUG	0
WITH PLUG	STE
Accessories for FFS05	
Connecting/extension cable, 3 m long	659R0112
Connecting/extension cable, silicone, 3 m long	659R0112/SI
Connecting/extension cable, 5 m long	659R0115
Connecting/extension cable, silicone, 5 m long	659R0115/SI
Connecting/extension cable, 10 m long	659R0114
Connecting/extension cable, silicone, 10 m long	659R0114/SI

Discontinued item.

Designation/type	Selection
Flame sensor FFS06, radial light entry opening, for flame monitoring device F150, F250 and ETAMATIC	659R30 ...
A 10 - "SPECTRUM"	
TYPE IR-1 T IR SPECTRAL REGION 1,200 – 2,800 nm for low flame frequencies, recommended for ETAMATIC	01T
TYPE UV-1 UV SPECTRAL REGION 260 – 400 nm	02
TYPE UV-2 UV SPECTRAL REGION 210 – 380 nm	05
A 20 - "CABLE LENGTH"	
CONNECTING CABLE, Length 2 m	2
CONNECTING CABLE, Length 5 m	5
CONNECTING CABLE, Length 10 m	10
CONNECTING CABLE, Length 0.3 m, only with plug	OE
A 30 - "PLUG"	
WITHOUT PLUG	0
WITH PLUG	STE
A 40 - "EXTENSION HOUSING"	
STANDARD, max. immersion depth, 65 mm	0
LONG DESIGN, max. immersion depth, 150 mm	L

**LAMTEC Meß- und Regeltechnik
für Feuerungen GmbH & Co. KG**

Josef-Reiert-Straße 26
D-69190 Walldorf, Germany
Telephone: +49 (0) 6227 6052-0
Fax: +49 (0) 6227 6052-57

info@lamtec.de
www.lamtec.de

