

Low Pressure Second Stage Regulators - Standard Settings LV4403B Series

Application

Designed to reduce first stage pressure of 5 to 20 PSIG (0.34 to 1.38 BARG) down to burner pressure, normally 11" w.c. Ideal for medium commercial installations, multiple cylinder installations and normal domestic loads.

Features

- Large vent helps prevent blockage and has 3/4" F.NPT for vent piping.
- With 15 PSIG inlet pressure, regulator is designed to not pass more than 2 PSIG with the seat disc removed.
- Incorporates integral relief valves.
- Replaceable valve orifice and valve seat disc.
- Straight line valve closure reduces wear on seat disc.
- Unique bonnet vent profile minimizes vent freeze over when properly installed.
- Large molded diaphragm is extra sensitive to pressure changes.
- Built in pressure tap has plugged 1/8" F.NPT outlet. Plug can be removed with a standard 7/16" wrench.
- Select brown finish.
- Temperature Range: -40°F to +165°F

Backmount Design

Mounts directly to house line piping. Eliminates need for union joints, elbows, and mounting brackets. Quick and easy to install.

Materials

Body Die Cast Zinc
 Bonnet Die Cast Zinc
 Nozzle Orifice Brass
 Spring Steel
 Valve Seat Disc Resilient Rubber
 Diaphragm Integrated Fabric and Synthetic Rubber

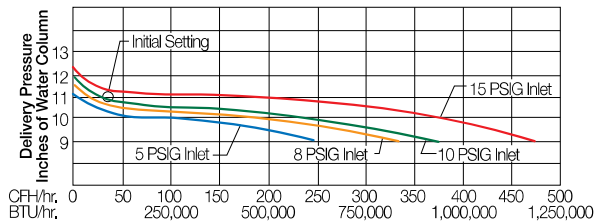

LV4403B Series

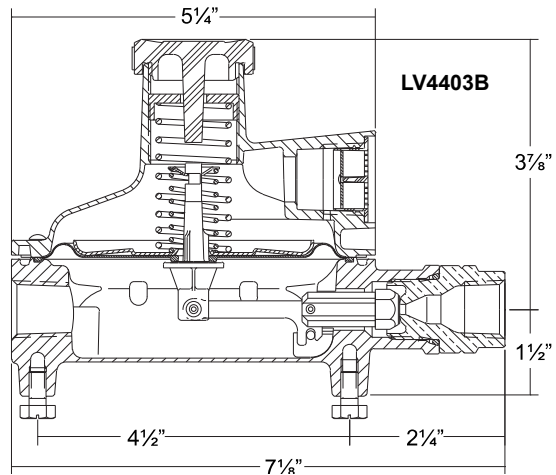
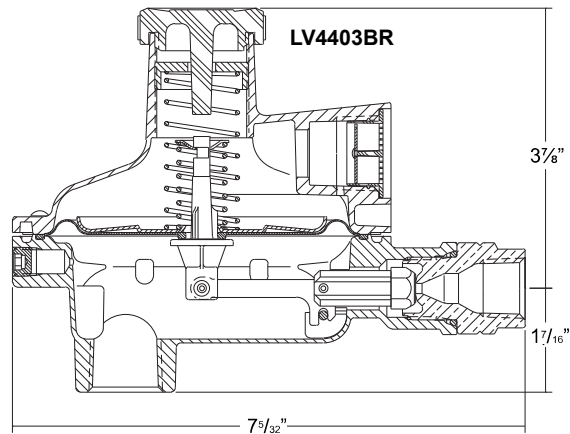

Ordering Information

Part Number	Inlet Connection	Outlet Connection	Orifice Size	Factory Delivery Pressure	Adjustment Range	Bonnet Vent Position	Vapor Capacity BTU/hr Propane****
LV4403B4*	1/2" F. NPT	1/2" F. NPT	#28 Drill (3.57mm)	11" w.c. at 10 PSIG Inlet (27.4 mbar at 0.69 bar)	9" to 13" w.c. (22.4 to 32.3 mbar)	Over Inlet	935,000 BTU/hr (20 KG/hr)
LV4403B46**		3/4" F. NPT					
LV4403B46R***		3/4" F. NPT					
LV4403B66**	3/4" F. NPT	3/4" F. NPT	#28 Drill (3.57mm)	11" w.c. at 10 PSIG Inlet (27.4 mbar at 0.69 bar)	9" to 13" w.c. (22.4 to 32.3 mbar)	Over Inlet	935,000 BTU/hr (20 KG/hr)
LV4403B66R***							

*Available in vent over outlet (VO) and vent at 9 O'clock(V9)

**Available in vent over outlet (VO), vent at 3 O'clock(V3) and vent at 9 O'clock(V9)

***Backmount design

****Maximum flow based on 10 PSIG(0.69 bar) inlet and 9" w.c.(22.4 mbar) delivery pressure.