

Braukmann D06FI

Pressure reducing valve

With balanced seat and stainless steel pattern

Application

According EN 806-2 pressure reducing valves of this type protect household water installations against excessive pressure from the supply. They can also be used for industrial or commercial applications within the range of their specification.

By installing a pressure reducing valve, pressurization damage is avoided and water consumption is reduced.

The set pressure is also maintained constant, even when there is wide inlet pressure fluctuation.

Reduction of the operating pressure and maintaining it at a constant level minimizes flow noise in the installation.

Approvals

- DVGW
- WRAS (up to 23 °C)

Special Features

- Inlet pressure balancing – no influence on outlet pressure by fluctuating inlet pressure
- Up to size 1¹/₄" approved by LGA for low noise, Group 1 without limitations
- The valve insert is of high-quality synthetic material and can be fully exchanged
- The outlet pressure is set by turning the adjustment knob
- The set pressure is directly indicated on the set point scale
- The adjustment spring is not in contact with the drinking water
- Integral fine filter
- Also available without fittings
- Conforms to BSEN 1567
- All materials are UBA conform
- All materials in contact with water are made of V4A stainless steel
- ACS certified
- 5-year warranty



Technical Data

| | |
|---|----------------|
| Media | |
| Medium: | Drinking water |
| Connections/Sizes | |
| Connection sizes: | 1/2" - 2" |
| Nominal sizes: | DN15 - DN50 |
| Pressure values | |
| Max. inlet pressure with clear filter bowl: | 16 bar |
| Max. inlet pressure with stainless steel filter bowl: | 25 bar |
| Outlet pressure: | 1.5 - 6 bar |
| Preset outlet pressure: | 3 bar |
| Min. pressure drop: | 1 bar |
| Operating temperatures | |
| Max. operating temperature medium (10 bar/stainless steel filter bowl): | 70 °C |
| Max. operating temperature medium accord. to EN 1567: | 30 °C |

Note: Use the SM06T brass filter bowl, if the valve can be exposed to UV radiation or solvent vapors.

Construction

| Overview | Components | Materials | |
|---|---|---|--|
|  | 1 | Spring bonnet with adjustment knob and setting scale | High-quality synthetic material |
| | 2 | Housing with pressure gauge connections on both sides | Stainless steel V4A |
| | 3 | Threaded male connections (options A & B) | Stainless steel V4A |
| | 4 | Pressure gauge connection | - |
| | 5 | Filter bowl | Clear synthetic or stainless steel V4A |
| Not depicted components: | | | |
| | Adjustment spring | Spring steel | |
| | Valve insert complete with diaphragm and valve seat | High-quality synthetic material, EPDM diaphragm | |
| | Fine filter with 0.16 mm mesh | Stainless steel V4A | |
| | Pressure gauge (see accessories) | High-quality synthetic material | |
| | Seals | EPDM | |

Method of Operation

Spring loaded pressure reducing valves operate by means of a force equalising system. The force of a diaphragm operates against the force of an adjustment spring. If the outlet pressure and therefore diaphragm force fall because water is drawn, the then greater force of the spring causes the valve to open. The outlet pressure then increases until the forces between the diaphragm and the spring are equal again.

The inlet pressure has no influence in either opening or closing of the valve. Because of this, inlet pressure fluctuation does not influence the outlet pressure, thus providing inlet pressure balancing.

Transportation and Storage

Keep parts in their original packaging and unpack them shortly before use.

The following parameters apply during transportation and storage:

| Parameter | Value |
|---------------------------------|--------------------------|
| Environment: | clean, dry and dust free |
| Min. ambient temperature: | 5 °C |
| Max. ambient temperature: | 55 °C |
| Min. ambient relative humidity: | 25 % * |
| Max. ambient relative humidity: | 85 % * |

*non condensing

Installation Guidelines

Setup requirements

- Horizontal and vertical installation position possible
- Install shut-off valves
- The device downstream should be protected by means of a safety valve (installed downstream of the pressure reducing valve)
- The installation location should be protected against frost and be easily accessible
 - Pressure gauge can be read off easily
 - Simplified maintenance and cleaning
- Provide a straight section of pipework of at least five times the nominal valve size after the pressure reducing valve (in accordance with EN 806-2)
- Requires regular maintenance in accordance with EN 806-5

Installation Example

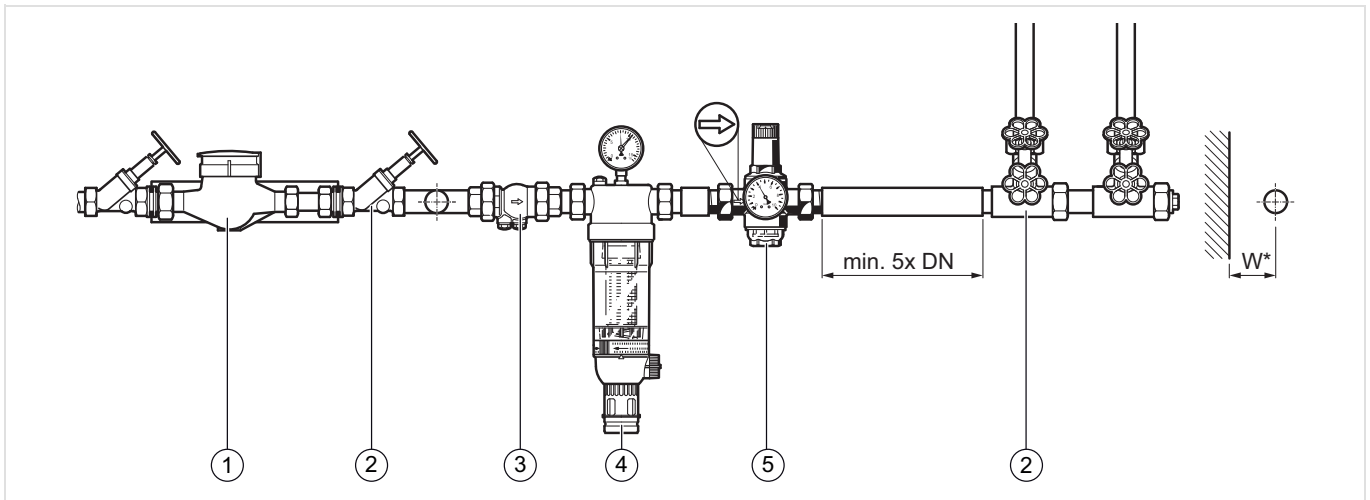

Fig. 1 Standard installation example for the pressure reducing valve

- 1 Water meter
- 2 Shut-off valve
- 3 Check valve
- 4 Filtering unit
- 5 Pressure reducing valve

| Connection sizes: | 1/2" | 3/4" | 1" | 1 1/4" | 1 1/2" | 2" |
|----------------------|------|------|----|--------|--------|----|
| Distance in mm (W*): | 55 | 55 | 60 | 60 | 70 | 70 |

* Required installation distances between the centerline of the pipework and the surrounding in dependency of the connection size.

Technical Characteristics

kvs-Values

| Connection sizes: | 1/2" | 3/4" | 1" | 1 1/4" | 1 1/2" | 2" |
|---|---------------|-------------|-------------|-------------|--------|------|
| k _{vs} -value (m ³ /h): | 2.4 | 3.1 | 5.8 | 5.9 | 12.6 | 12.0 |
| IfBt designation: | P-IX 1582/I | P-IX 1582/I | P-IX 1582/I | P-IX 1582/I | - * | - * |
| DIN/DVGW Registration No.: | DW-6330AT2314 | | | | | |

* Compulsory testing in sizes R 1 1/2" to R 1 1/4"

Pressure drop characteristics

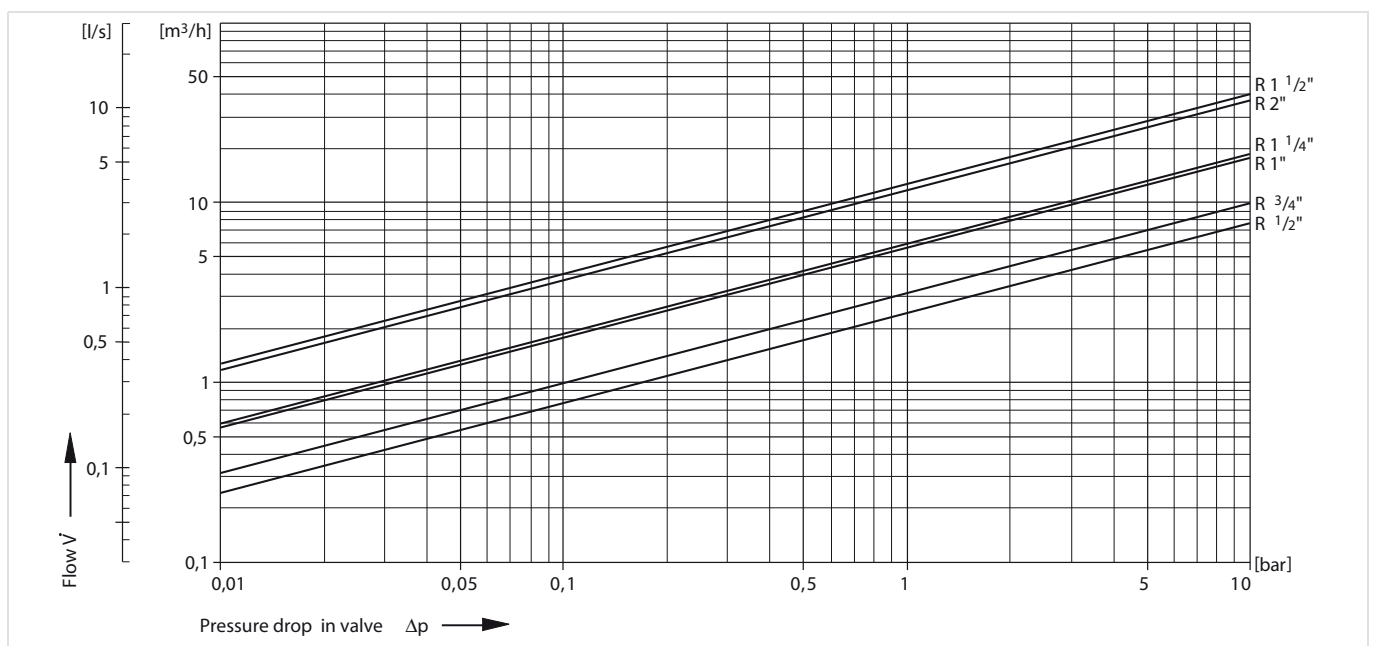
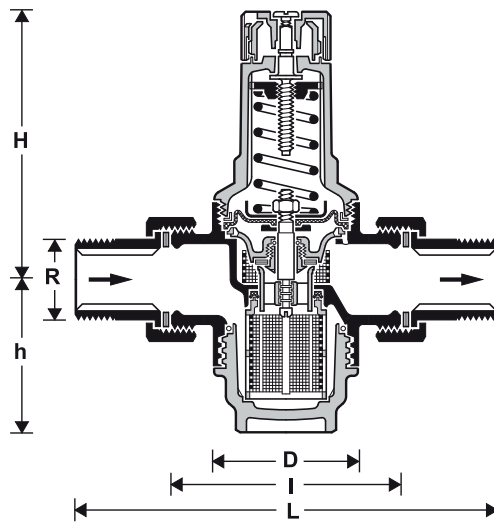

Fig. 2 Pressure drop within the valve in dependency of the flow rate and the used connection size

Dimensions

Overview



| Parameter | Values | | | | | | |
|------------------------|--------|------|------|-----|--------|--------|-----|
| Connection sizes: | R | 1/2" | 3/4" | 1" | 1 1/4" | 1 1/2" | 2" |
| Nominal size diameter: | DN | 15 | 20 | 25 | 32 | 40 | 50 |
| Weight: | kg | 0.7 | 0.8 | 1.2 | 1.6 | 2.9 | 3.6 |
| Dimensions: | L | 140 | 160 | 180 | 200 | 225 | 255 |
| | I | 80 | 90 | 100 | 105 | 130 | 140 |
| | H | 89 | 89 | 111 | 111 | 173 | 173 |
| | h | 58 | 58 | 64 | 64 | 126 | 126 |
| | D | 54 | 54 | 61 | 61 | 82 | 82 |

Note: All dimensions in mm unless stated otherwise.

Ordering Information

The following tables contain all the information you need to make an order of an item of your choice. When ordering, please always state the type, the ordering or the part number.

Options

The valve is available in the following sizes: 1/2", 3/4", 1", 1 1/4", 1 1/2" and 2".



- standard
- not available

| | | D06FI-...A | D06FI-...B | D06FI-...E | D06FI-...BE |
|------------------------------------|--|------------|------------|------------|-------------|
| Max. operating temperature medium: | 40 °C | • | – | • | – |
| | 70 °C | – | • | – | • |
| Filter bowl: | clear | • | – | • | – |
| | stainless steel V4A | – | • | – | • |
| Connection type: | external threaded connection set on in- and outlet | • | • | – | – |
| | external thread on in- and outlet | – | – | • | • |

Note: ... = space holder for connection size

Note: Ordering number example for 1 1/4" and type A valve: D06FI-11/4A

Accessories

| | Description | Dimension | Item No. | |
|---|-----------------|---|-----------|---------------|
|  | M07M | Pressure gauge | | |
| | | Housing diameter 63 mm, rear connection thread G 1/4" | | |
| | | Range: 0 - 4 bar | | M07M-A4 |
| | | Range: 0 - 10 bar | | M07M-A10 |
| | | Range: 0 - 16 bar | | M07M-A16 |
| | | Range: 0 - 25 bar | | M07M-A25 |
|  | ZR06K | Double ring wrench | | |
| | | For removal of spring bonnet and filter bowl | | ZR06K |
|  | VST06I-A | Connection set | | |
| | | With stainless steel V4A threaded connections | | |
| | | | 1/2" | VST06I-1/2A |
| | | | 3/4" | VST06I-3/4A |
| | | | 1" | VST06I-1A |
| | | | 1 1/4" | VST06I-1 1/4A |
| | | | 1 1/2" | VST06I-1 1/2A |
| | | 2" | VST06I-2A | |

Spare Parts

Pressure Reducing Valve D06FI, from 2007 onwards

| Overview | Description | Dimension | Item No. |
|--|---|-------------|-------------|
| | 1 Spring bonnet complete | | |
| | | 1/2" - 1" | 0901515 |
| | | 1" + 1 1/4" | 0901517 |
| | | 1 1/2" + 2" | 0901518 |
| | 2 Valve insert complete (without filter) | | |
| | | 1/2" + 3/4" | D06FI-1/2 |
| | | 1" + 1 1/4" | D06FI-1 |
| | | 1 1/2" + 2" | D06FI-11/2 |
| | 3 Union seal washer (10 pcs.) | | |
| | | 1/2" | 0901443 |
| | | 3/4" | 0901444 |
| | | 1" | 0901445 |
| | | 1 1/4" | 0901446 |
| | | 1 1/2" | 0901447 |
| | | 2" | 0901448 |
| | 4 Blanking plug with O-ring R1/4" (5 pcs.) | | |
| | | 1/2" - 2" | S06K-1/4 |
| | 5 Replacement filter insert | | |
| | | 1/2" + 3/4" | ES06F-1/2A |
| | | 1" + 1 1/4" | ES06F-1B |
| | | 1 1/2" + 2" | ES06F-11/2A |
| | 6 O-ring set (10 pcs.) | | |
| | | 1/2" + 3/4" | 0901246 |
| | | 1" + 1 1/4" | 0901499 |
| | 1 1/2" + 2" | 0901248 | |
| 7 Clear filter bowl with O-ring | | | |
| | 1/2" + 3/4" | SK06T-1/2 | |
| | 1" + 1 1/4" | SK06T-1B | |
| | 1 1/2" + 2" | SK06T-11/2 | |
| 8 Stainless steel filter bowl with O-ring | | | |
| | 1/2" + 3/4" | SI06T-1/2 | |
| | 1" + 1 1/4" | SI06T-1 | |
| | 1 1/2" + 2" | SI06T-11/2 | |



Ademco 1 GmbH, Hardhofweg 40,
74821 MOSBACH, GERMANY
Phone: +49 6261 810

Manufactured for and on behalf of
Pittway Sàrl, Z.A., La Pièce 6,
1180 Rolle, Switzerland
by its authorised representative
Ademco 1 GmbH

Subject to change. EN0H-1035GE23 R1124
© 2024 Resideo Technologies, Inc.
All rights reserved.

For more information
resideo.com

This document contains proprietary information of Pittway Sàrl and its affiliated companies and is protected by copyright and other international laws. Reproduction or improper use without specific written authorization of Pittway Sàrl is strictly forbidden.