



บริษัท เอดีดี เฟอร์เนส จำกัด

**ADD FURNACE CO.,LTD.**

44 ซอยบรมราชชนนี 70 ถนนบรมราชชนนี แขวงศาลาธรรมสพน์ เขตทวีวัฒนา กรุงเทพฯ 10170

โทร: 02-888-3472 โทร: ออกแบบ:08-08-170-170 แฟกซ์: 02-888-3258

<https://www.add-furnace.com> E-mail: [sales@add-furnace.com](mailto:sales@add-furnace.com)

## Shimaden, Temperature and Humidity Control Specialists

°C	<b>SERIES PAC35</b>
%RH	
<b>SHIMADEN</b>	

# THREE-PHASE POWER REGULATOR

### BASIC FEATURES

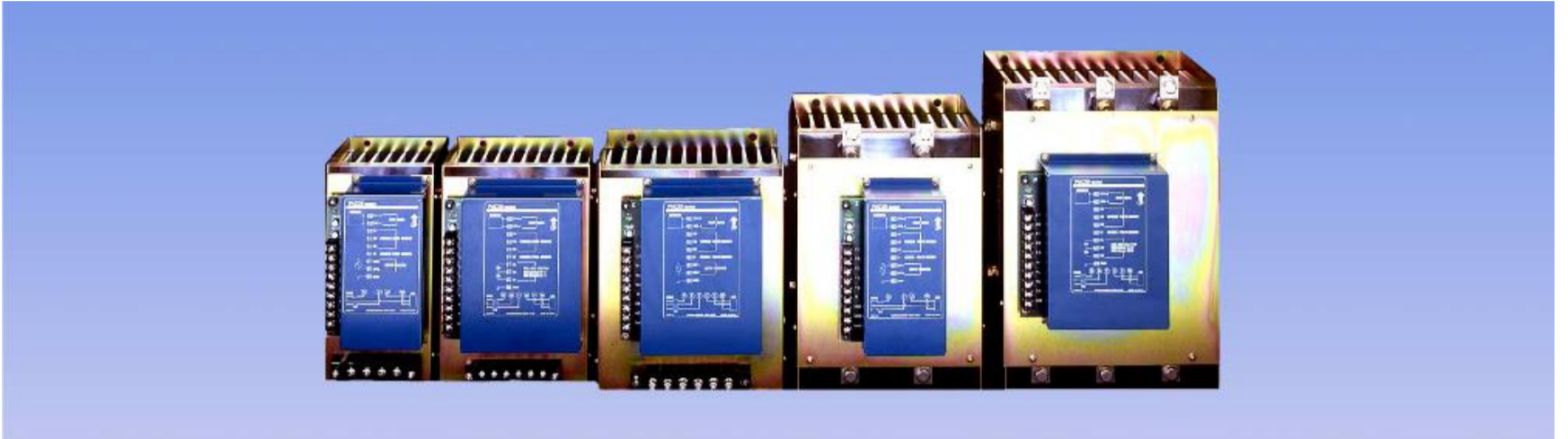

- Phase Angle or Zero Voltage Switching**
- Current Capacity: 20, 30, 45, 60, 90, 135A**
- Power Supply: 200~240 or 380~440V AC**

### SPECIFICATIONS

Power Supply:	See Ordering Information.
Current Capacity:	See Ordering Information.
Control Input:	
Current:	4~20mA DC/Receiving impedance: 100Ω
Contact:	Non-voltage contact signal
Thyristor Control Action:	Phase angle or zero voltage switching
Possible Loads:	
Phase angle:	Resistance load (transformer primary control possible)
Zero voltage switching:	Constant resistance load
Proportional Cycle:	
Phase angle:	None
Cycle base	
zero voltage switching:	None
Time base	
zero voltage switching:	Approx. 3 sec. (internally adjustable 2~4 sec.)
Output Control Range:	
Phase angle:	0~95% min. of input voltage
Zero voltage switching:	0~95% min. of load power
Power Adjuster:	
Current input type:	Internal installation as standard (External installation available as option)
Contact input type:	External installation as standard
SCR Element:	
Phase angle:	SCR × 3 and diode × 3 3-phase anti-parallel connection
Zero voltage switching:	SCR × 2 2-phase anti-parallel connection
Power Lamp:	Green LED
Power Supply Cycle:	50/60Hz
Over-Current Protection:	None available (Use fuse for semiconductor.)
Thyristor Element Cooling:	20~90A (natural air), 135A (fan cooled)
Minimum Loads:	10% min. of current capacity (no operation at no load)
Operating Ambient Temperature Range:	-10~+50 °C
Operating Ambient Humidity:	90% RH max.
Insulation Resistance:	20MΩ min. at 500V DC between control input and power supply terminals 20MΩ min. at 500V DC between power supply terminals and chassis
Dielectric Strength:	1 min. at 1000V AC between control input and power supply terminals 1 min. at 2000V AC between power supply terminals and chassis
External Dimensions	See page 6.



บริษัท เอดีดี เฟอร์เนส จำกัด

**ADD FURNACE CO.,LTD.**

44 ซอยบรมราชชนนี 70 ถนนบรมราชชนนี แขวงศาลาธรรมสพน์ เขตทวีวัฒนา กรุงเทพฯ 10170

โทร: 02-888-3472 โทร: ออกแบบ:08-08-170-170 แฟกซ์: 02-888-3258

https://www.add-furnace.com E-mail: [sales@add-furnace.com](mailto:sales@add-furnace.com)

**ORDERING INFORMATION PAC35P**

**Series PAC35**

ITEMS	CODE	SPECIFICATIONS	
SERIES	PAC35P	Phase Angle 3-phase Power Regulator With Soft-Start	
CONTROL INPUT	0	4~20mA DC impedance: 100Ω	
	2	Non-voltage contact	
	9	Others (Please consult before ordering.)	
CURRENT CAPACITY	020	20A	
	030	30A	
	045	45A	
	060	60A	
	090	90A	
	135	135A	
POWER SUPPLY	37-	200~240V AC±10% 50/60Hz	
	35-	380~440V AC±10% 50/60Hz	
	99-	Others (Please consult before ordering.)	
EXTERNAL POWER ADJUSTER	N	None (Internal standard)	Current input
	P	External power adjuster	
	M	Manual power adjuster	
	B	Base power adjuster	
	W	External power adjuster + Manual power adjuster	
	Y	External power adjuster + Base power adjuster	
	P	High power adjuster (standard)	Contact input
	B	High power adjuster (standard) + Low power adjuster	
	X	Others (Please consult before ordering.)	
REMARKS	0	Without	
	9	With (Please consult before ordering.)	

**TERMINAL ARRANGEMENT PAC35P (Phase Angle)**

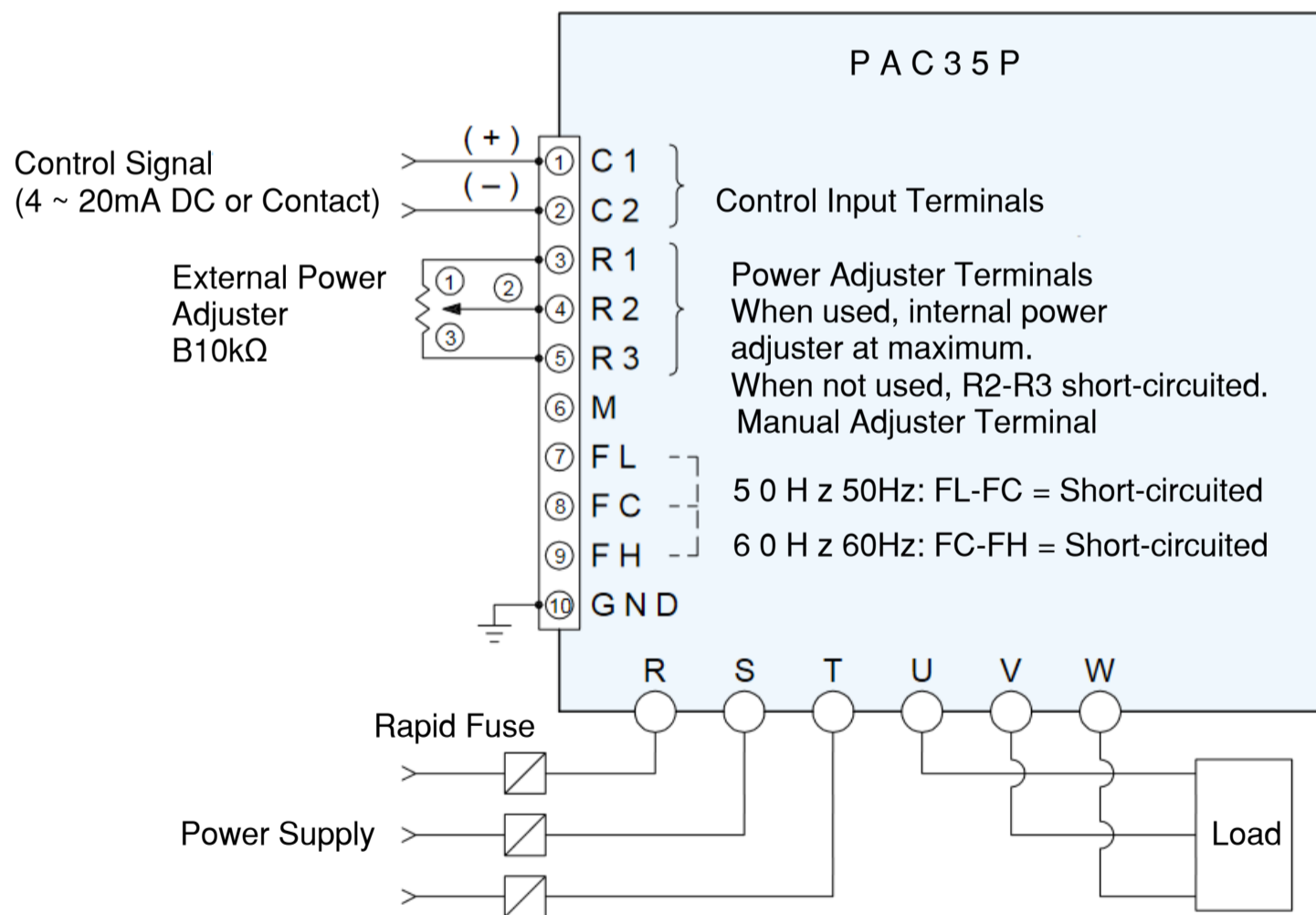



บริษัท เอดีดี เฟอร์เนส จำกัด

**ADD FURNACE CO.,LTD.**

44 ซอยบรมราชชนนี 70 ถนนบรมราชชนนี แขวงศาลาธรรมสพน์ เขตทวีวัฒนา กรุงเทพฯ 10170

โทร: 02-888-3472 โทร: ออกแบบ:08-08-170-170 แฟกซ์: 02-888-3258

https://www.add-furnace.com E-mail: [sales@add-furnace.com](mailto:sales@add-furnace.com)

**ORDERING INFORMATION PAC35C**

**Series PAC35**

ITEMS	CODE		SPECIFICATIONS	
SERIES	PAC35C		Cycle Base Zero Voltage Switching (3-Phase)	
CONTROL INPUT	0		4~20mA DC Receiving impedance: 100Ω	
	2		Non-voltage contact	
	9		Others (Please consult before ordering.)	
CURRENT CAPACITY	020		20A	
	030		30A	
	045		45A	
	060		60A	
	090		90A	
	135		135A	
POWER SUPPLY	37-		200~240V AC±10% 50/60Hz	
	35-		380~440V AC±10% 50/60Hz	
	99-		Others (Please consult before ordering.)	
EXTERNAL POWER ADJUSTER	N		None (Internal standard)	Current input
	P		External power adjuster	
	M		Manual power adjuster	
	B		Base power adjuster	
	W		External power adjuster + Manual power adjuster	
	Y		External power adjuster + Base power adjuster	
	P		High power adjuster (standard)	Contact input
	B		High power adjuster (standard) + Low power adjuster	
	X		Others (Please consult before ordering.)	
MANIPULATED VARIABLE (POWER) OUTPUT AND/OR INDICATOR	0		None	
	1		Manipulated variable output	
	2		Manipulated variable + indicator	
REMARKS	0		Without	
	9		With (Please consult before ordering.)	

**TERMINAL ARRANGEMENT PAC35C (Cycle Base Zero Voltage Switching)**

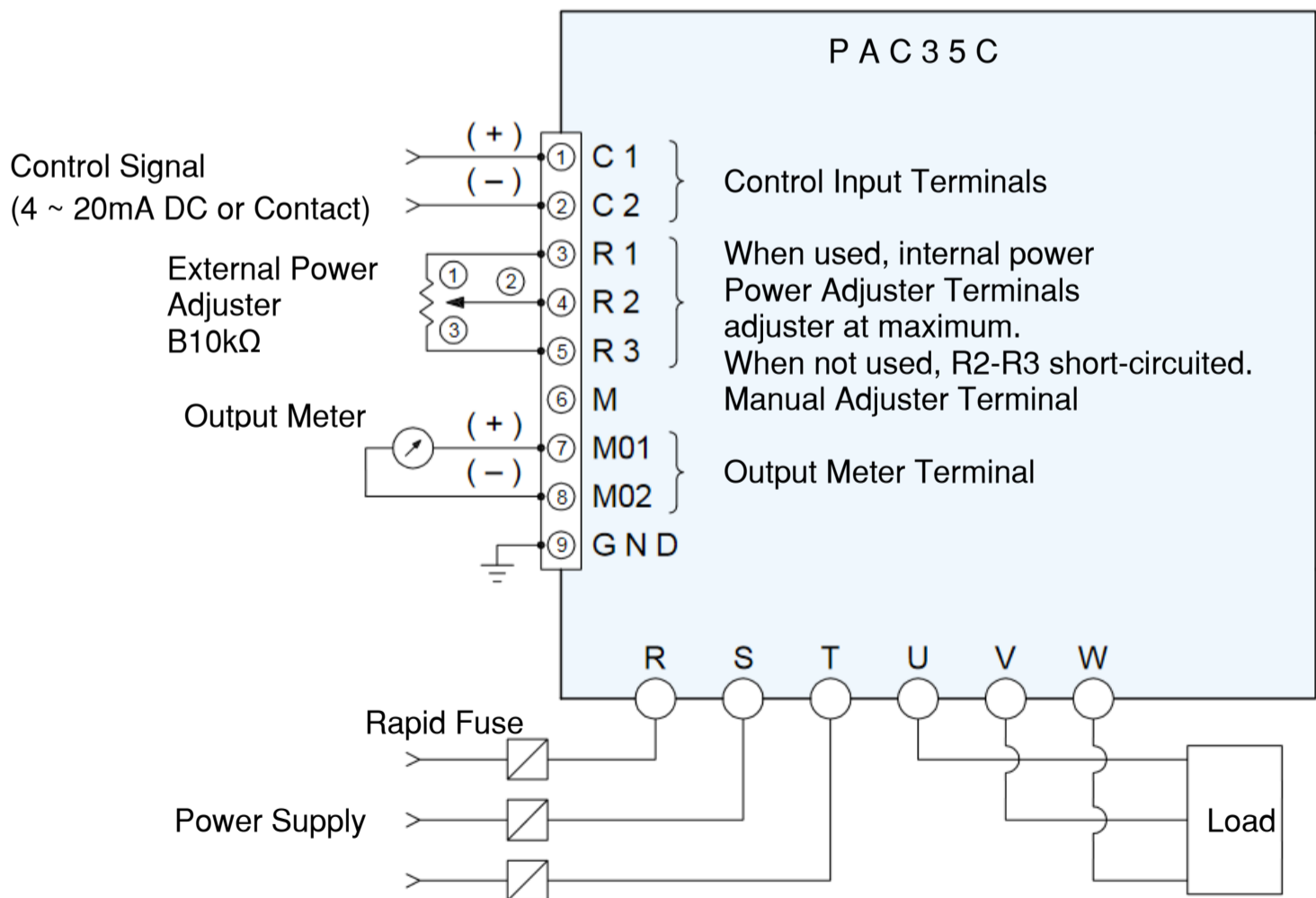



บริษัท เอดีดี เฟอร์เนส จำกัด

**ADD FURNACE CO.,LTD.**

44 ซอยบรมราชชนนี 70 ถนนบรมราชชนนี แขวงศาลาธรรมสพน์ เขตทวีวัฒนา กรุงเทพฯ 10170

โทร: 02-888-3472 โทร: ออกแบบ:08-08-170-170 แฟกซ์: 02-888-3258

https://www.add-furnace.com E-mail: [sales@add-furnace.com](mailto:sales@add-furnace.com)

**ORDERING INFORMATION PAC35Z**

**Series PAC35**

ITEMS	CODE		SPECIFICATIONS	
SERIES	PAC35Z		Time Base Zero Voltage Switching (3-Phase)	
CONTROL INPUT	0		4~20mA DC Receiving impedance: 100Ω	
	2		Non-voltage contact	
	9		Others (Please consult before ordering.)	
CURRENT CAPACITY	020		20A	
	030		30A	
	045		45A	
	060		60A	
	090		90A	
	135		135A	
POWER SUPPLY	37-		200~240V AC±10% 50/60Hz	
	35-		380~440V AC±10% 50/60Hz	
	99-		Others (Please consult before ordering.)	
EXTERNAL POWER ADJUSTER	N		None (Internal standard)	
	P		External power adjuster	
	M		Manual power adjuster	
	B		Base power adjuster	
	W		External power adjuster + Manual power adjuster	
	Y		External power adjuster + Base power adjuster	
	P		High power adjuster (standard)	
	B		High power adjuster (standard) + Low power adjuster	
	X		Others (Please consult before ordering.)	
MANIPULATED VARIABLE (POWER) OUTPUT AND/OR INDICATOR	0		None	
	1		Manipulated variable output	
	2		Manipulated variable + indicator	
REMARKS	0		Without	
	9		With (Please consult before ordering.)	

**TERMINAL ARRANGEMENT PAC35Z (Time Base Zero Voltage Switching)**

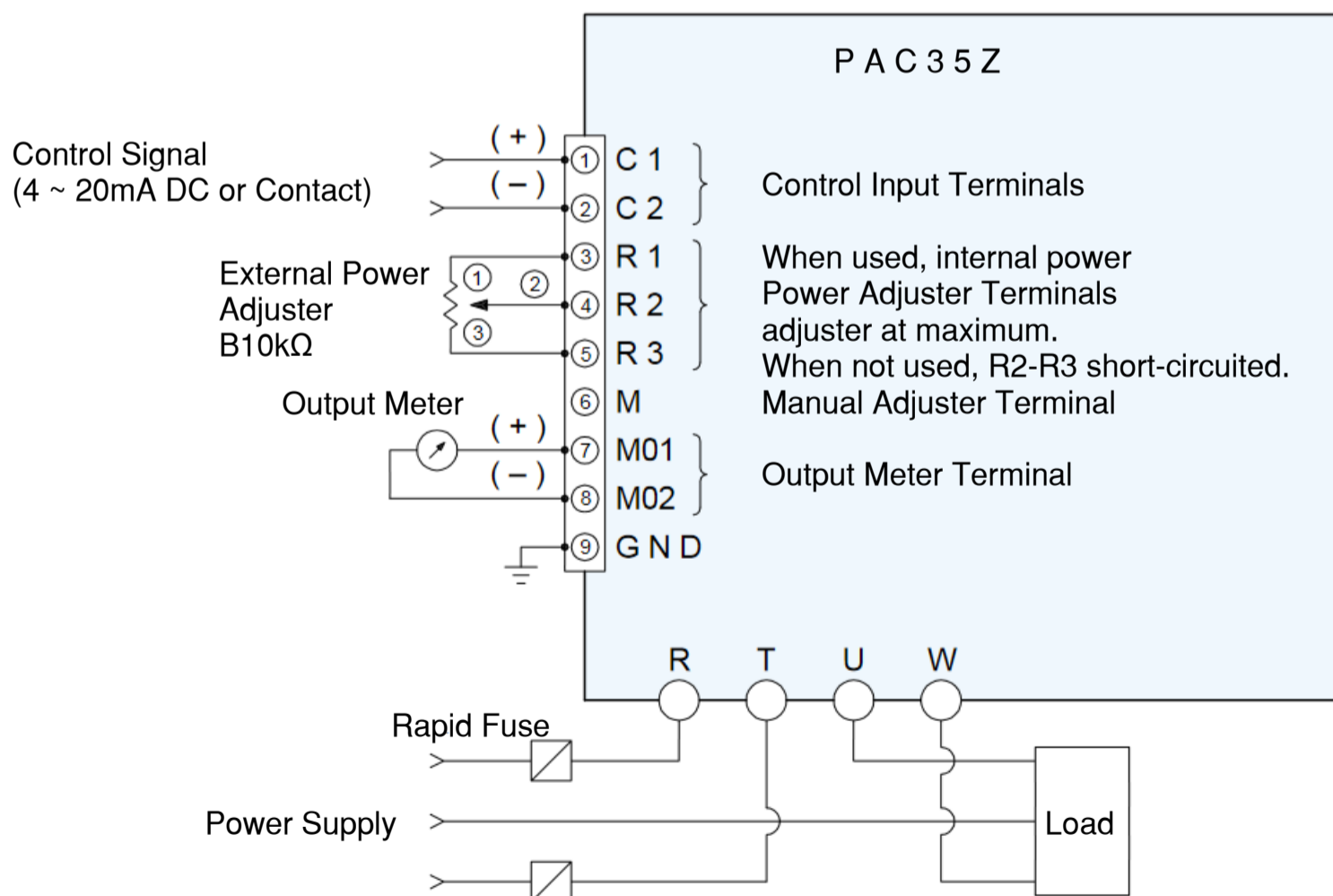



**POWER ADJUSTER CONNECTIONS**

**Series PAC35**

**Base Power Control (Current Input Type)**

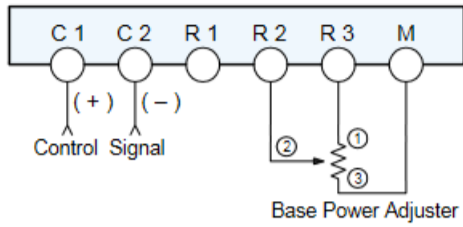

**Auto / Manual Selectable (Current / Contact Type)**

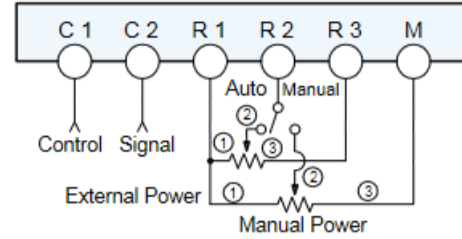

**External Power Adjust / Base Power Adjust (Current Input Type)**

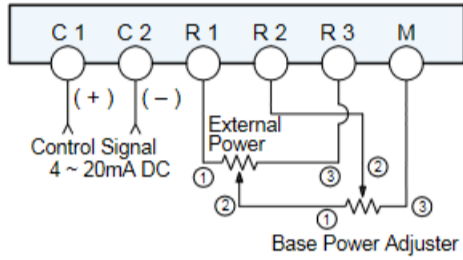

**High / Low Adjust (Contact Input Type)**

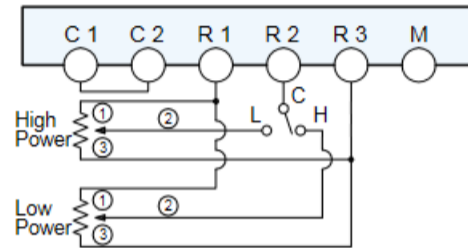

\*External power adjuster and base power adjuster correspond with each other.  
\*Internal power adjuster = at maximum

0~100% output adjustment is available with high and low power adjusters.

**CONTROL MODE & WAVE FORM**

Control Mode	Noise	Output Voltmeter Deflection	Output Wave Form		
			10% Output	50% Output	90% Output
Phase angle control (P)	Little	Continuous			
Cycle base zero voltage switching (C)	None	Large deflection (with low output) Almost continuous (with mid & high output)	 1 cycle ON and 9 cycles OFF	 1 cycle ON and 1 cycle OFF	 9 cycles ON and 1 cycle OFF
Time base zero voltage switching (Z)	None	intermittent	 T	 T=3 sec.	 T=Proportional Cycle

Capacity (A)	20	30	45	60	90	135
Heating Value (W)	PAC35P/C					
	69	105	141	172	270	445
	PAC35Z					
	45	69	93	125	175	300

**Mounting Space**

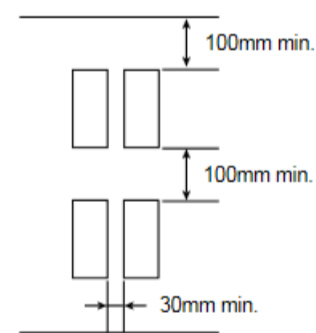

\* Care must be taken for air ventilation.

\* Vertical mounting is recommended. Refer to the mounting space diagram.

When mounting horizontally, use at 60% maximum of the capacity.

**EXTERNAL OPTIONS**

- External (High) Power Adjuster (0~100%)
- Base (Low) Power Adjuster (0~100%)
- Manual Power Adjuster (0~100%)
- Current Limiter (50~100%)

**External Power adjuster**



- Resistance: B10kΩ 1W
- Lead wire length: 1m

**Power Adjuster Dimensions**

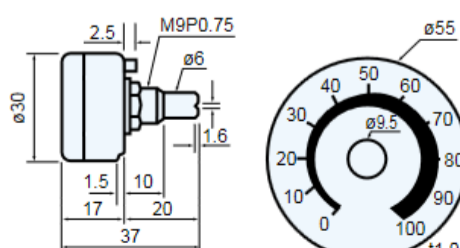

**Panel cutout**

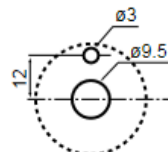

**Manipulated Variable Output Indicator (Zero Voltage Switching Models Only)**

**Output Indicator**



- Range: 0~100%
- Sensitivity: 1mA FS

**Indicator Dimensions**

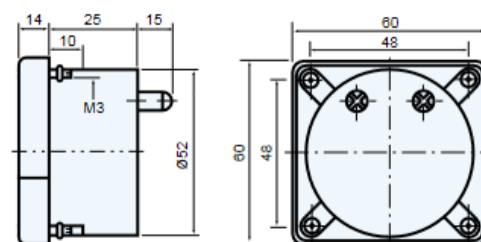

Unit: mm



บริษัท เอดีดี เฟอร์เนส จำกัด

ADD FURNACE CO.,LTD.

44 ซอยบรมราชชนนี 70 ถนนบรมราชชนนี แขวงศาลาธรรมสพน์ เขตทวีวัฒนา กรุงเทพฯ 10170

โทร: 02-888-3472 โทร: ออกแบบ:08-08-170-170 แฟกซ์: 02-888-3258

https://www.add-furnace.com E-mail: [sales@add-furnace.com](mailto:sales@add-furnace.com)

## EXTERNAL DIMENSIONS & WEIGHT

## Series PAC35

### □ PAC35P / PAC35C 20A, 30A

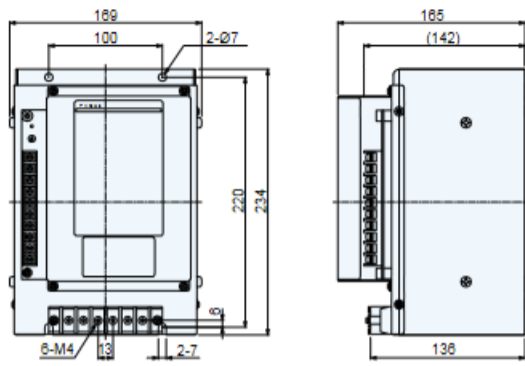

Weight: Approx. 3.0kg / 20A  
Approx. 5.2kg / 30A

### □ PAC35Z 20A, 30A, 45A

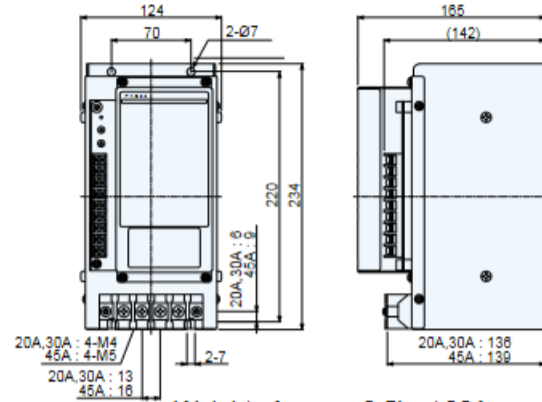

Weight: Approx. 2.5kg / 20A  
Approx. 3.8kg / 30A, 45A

### □ PAC35P / PAC35C 45A, 60A

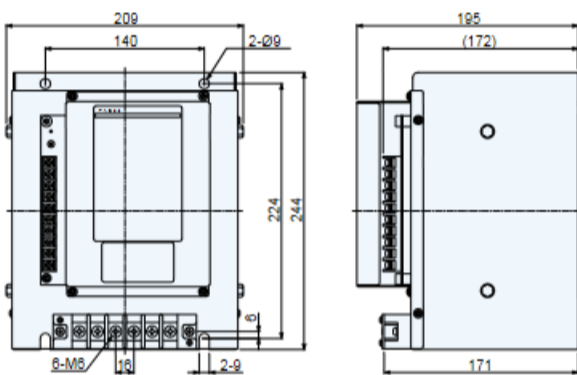

Weight: Approx. 7.6kg

### □ PAC35Z 60A, 90A, 135A

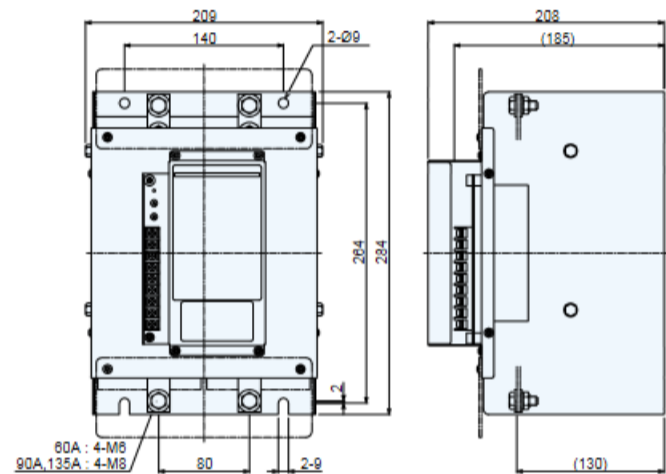

Weight: Approx. 8.4kg / 60A, 90A  
Approx. 9.4kg / 135A

### □ PAC35P / PAC35C 90A, 135A

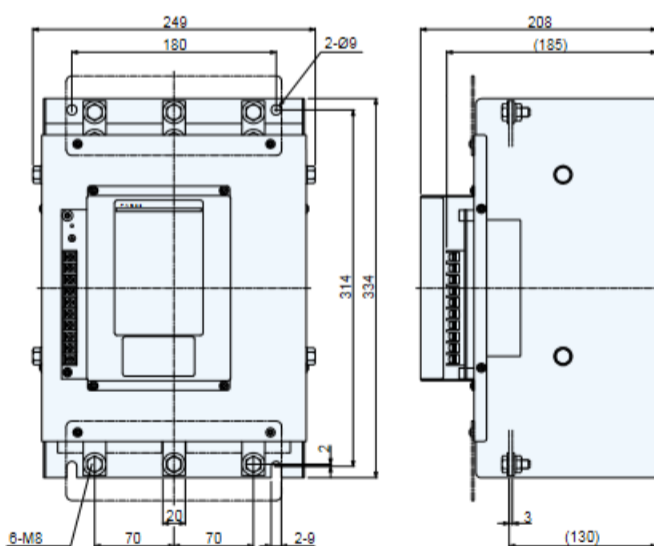

Weight: Approx. 12kg / 90A  
Approx. 13kg / 135A

Unit : mm

### ⚠ Warning

- The PAC35 series is designed for controlling the power of a heater or similar equipment used in a general industrial facilities. (It is not to be used for any purpose which regulates the prevention of serious effects on human life or safety.)

### ⚠ Caution

- If the possibility of loss or damage to your system or property as a result of failure of any part of the process exists, proper safety measures must be made before the instrument is put into use so as to prevent the occurrence of trouble.