



บริษัท เอดีดี เฟอร์เนส จำกัด

ADD FURNACE CO.,LTD.

44 ซอยบรมราชชนนี 70 ถนนบรมราชชนนี แขวงศาลาธรรมสพน์ เขตทวีวัฒนา กรุงเทพฯ 10170

โทร: 02-888-3472 โทร: ออกแบบ:08-08-170-170 แฟกซ์: 02-888-3258

<https://www.add-furnace.com> E-mail: sales@add-furnace.com

Shimaden, Temperature and Humidity Control Specialists

°C	Series PAC36P THYRISTOR THREE PHASE POWER REGULATOR
%RH	

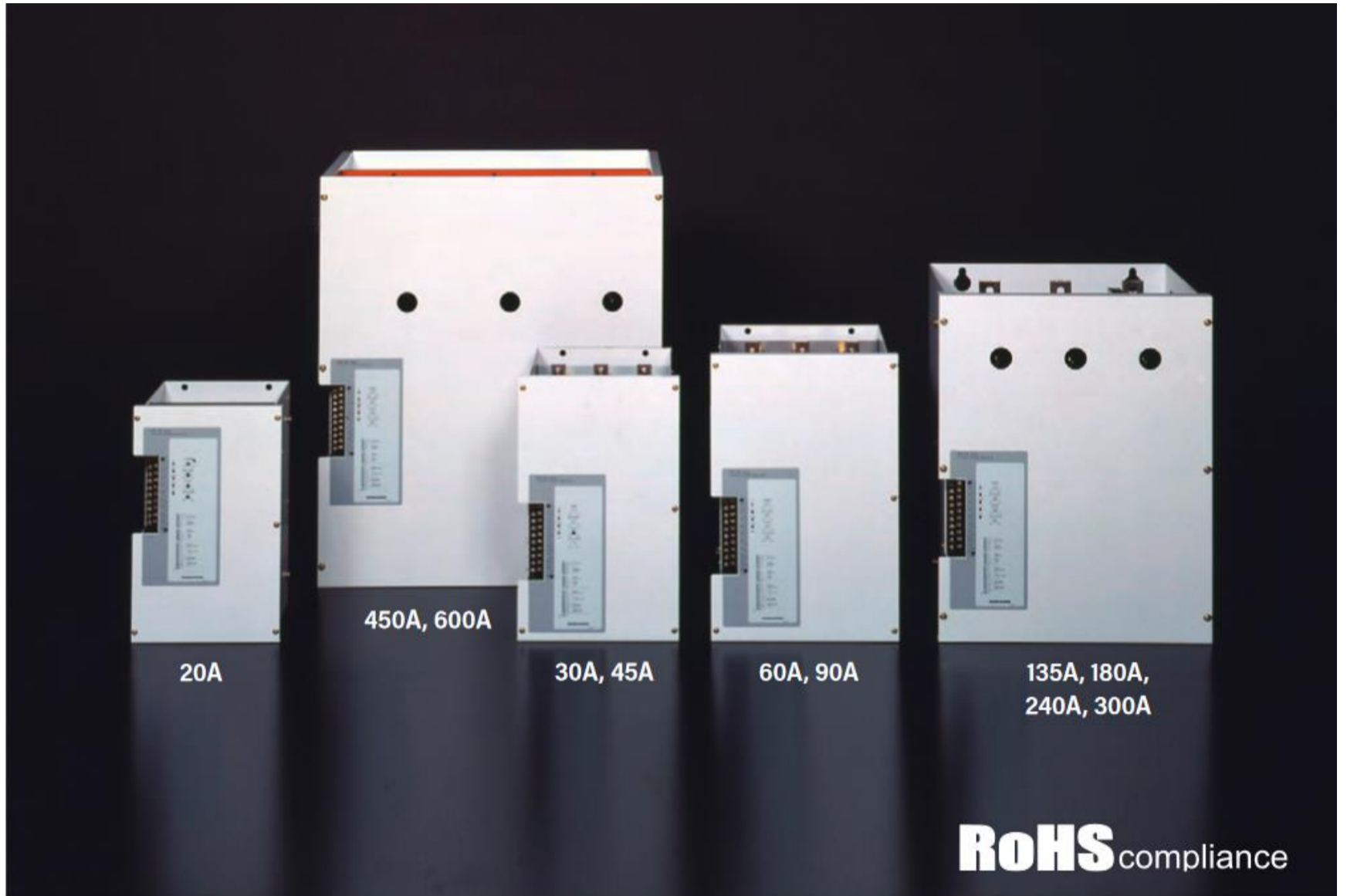

BASIC FEATURES

- Wide application with variety of functions**
- Suitable for air conditioning, electric, furnace, dryer, bio engineering, food industry, chemical industry, plastic formation and control of heat source applications.**
- Power Supply: 200–240V or 380–440V AC**
- 6 toxic substances, which are subject to RoHS Directive, are contained. However, the amount of toxic substances contained does not exceed standardized values.**



บริษัท เอดีดี เฟอร์เนส จำกัด

ADD FURNACE CO.,LTD.

44 ซอยบรมราชชนนี 70 ถนนบรมราชชนนี แขวงศาลาธรรมสพน์ เขตทวีวัฒนา กรุงเทพฯ 10170

โทร: 02-888-3472 โทร: ออกแบบ:08-08-170-170 แฟกซ์: 02-888-3258

https://www.add-furnace.com E-mail: sales@add-furnace.com

FUNCTION

Series PAC36P

Standard Function

Electronic over current protect function:	Protects thyristor element by shutting off the over current detected by a load current monitoring CT.
Constant voltage characteristics by means of voltage feedback:	Stable output provided by the voltage control function and easy operation achieved by the linear characteristics of control input and output voltage. Soft start function: Setting suitable soft start time for the load.

Additional Function (option)

Automatic power adjusting function:	Stable output provided by the voltage control function and easy operation achieved. The suitable power for the control temperature is continuously controlled by a signal from the programmable controller, computer and adjuster. Applicable for soft control of the low range.
Constant-current control (Current feedback):	Applicable to controlling the pure metallic heater and the Kanthal Super heater.
Constant-power control (Power feedback):	Applicable to controlling the SiC and the carbon heater, and applicable to high stability controlling.
Power linear control (Voltage square feedback):	Applicable to precise controlling for Nichrome heater load with power linear characteristics of the control input / output voltage.
Current limiting function:	Applicable to loads with rush current on starting and continuous usage over current condition such as pure metallic, Tungsten and Molybdenum heaters.
Start up output limiting function:	Applicable to the rush current reduction and load protection on turning on the power supply.
Heater break alarm:	Alarm display and output in case of detecting the low power condition of the broken heater and heater defect.
Rapid fuse:	Perfect protection for the thyristor device and the power line from the over current of the short circuit and the grounding.
Power adjustment function:	Addition of various manual equipment used for adjusting ramp, base (residual output), manual and high / low

Monitor and Alarm Output on the Trouble Situation

Over-current protection:	[O.C] monitor lights and alarm output on
Fan stop (for models over 180A):	[FAN] monitor lights and alarm output on
Rapid fuse burnt out:	[FUSE] monitor lights and alarm output on
Heater break alarm:	[H / B] monitor lights and warning output on

SPECIFICATION

Control input and Rating:	Current input:	4–20mA / DC, Receiving impedance: 100Ω
	Voltage input:	1–5V / DC, Input impedance: 200kΩ min. 0–10V / DC, Input impedance: 200kΩ min.
Power Supply and Rating:	Contact signal:	Non-voltage contact signal
	Note:	Select external power (P) or (H) in the table of code Selection Item 7, (Output Adjusting Function)
	200V type:	200–220V AC ±10% 50/60Hz 220–240V AC ±10% 50/60Hz
	400V type:	380–400V AC ±10% 50/60Hz 400–440V AC ±10% 50/60Hz
Control Mode:	Phase angle control system	
	Soft start:	Adjustable approx. 1–10 sec. (time for reaching 90%)
Over-current Protection System:	Applicable load:	Resistive load (additional function selected according to characteristics) Inductive load (transformer primary side control)
	Output voltage control range:	0–98% minimum of input voltage
	Output stability (95% or less of output voltage):	Input fluctuation ±2% or less when input fluctuation is ±10%.
	Control element configuration:	Mixed antiparallel configuration of SCRs and diode
	Electronic type (gate signal breaking system) standard:	approx. 130% of rated current
	Rapid fuse type (optional):	130–150% of rated current
Current Capacity and Cooling System:	Reset Electronic type:	Turn power OFF and reapply
	Rapid fuse:	Replace fuse.
	20A, 30A, 45A, 60A, 90A, 135A:	Self-cooling system
	180A, 240A, 300A, 450A, 600A:	Forced air cooling system
	Over-current:	[O.C] monitor lights. / AL1-AL2 conducting
	Fan stop:	[FAN] monitor lights. / AL1-AL2 conducting
Alarm Monitors and Rating	Fuse burnt out:	[FUSE] monitor lights./AL1-AL2 conducting
	Heater break:	[H / B] monitor lights. / HB1-HB2 conducting
	Output contact rating:	240V AC 1A / Resistive load



บริษัท เอดีดี เฟอร์เนส จำกัด

ADD FURNACE CO.,LTD.

44 ซอยบรมราชชนนี 70 ถนนบรมราชชนนี แขวงศาลาธรรมสพน์ เขตทวีวัฒนา กรุงเทพฯ 10170

โทร: 02-888-3472 โทร: ออกแบบ:08-08-170-170 แฟกซ์: 02-888-3258

<https://www.add-furnace.com> E-mail: sales@add-furnace.com

SPECIFICATION

Series PAC36P

Power Lamp	Correct Phase sequence:	Green LED lights.
	Open / opposite phase sequence:	Red LED lights.
Operating Environment	Ambient temperature range:	-10~50 °C
	Ambient humidity:	90% RH max. with no condensation
Insulation Resistance	Power terminal and chassis:	500V DC 20MΩ min.
	Input terminal and power terminal:	500V DC 20MΩ min.
Dielectric Strength	Power terminals and chassis:	
	200~240V power supply:	2000V AC 1 minute
	380~440V power supply:	2500V AC 1 minute
Material / Finish	Ordinary steel plate / paint coating (equivalent to N8.5 Munsell number)	
External Dimensions and Weight:	See external demension drawings.	
Terminal Cover:	Installed as standard equipment.	
Additional functions (option)	Power adjuster	
	Connection to voltage / current output type controller	
	Internal Power (standard):	0~100%
	External Power:	0~100%
	Manual Power:	0~100%
	Base Power:	0~100%
	External power + Manual power:	0~100%
	External power + Base power:	0~100%
	Connection to contact output type controller	
	External Power:	0~100%
	High-low power, High power:	0~100%
	Low power:	High power × Low power
	Constant-current control (current feedback) Applicable loads:	Pure metallic heaters, Super kanthal, etc.
	Constant-power control (power feedback) Applicable loads:	SiC, Carbon heaters
	Power linear control (voltage feedback) Applicable loads:	Nichrome heater
	Output limiting function:	Current limit: 50~100% of rated current
	Start up output limiting:	0~60% output for 1~60sec.
	Rapid fuse:	With alarm output function
	Heater break alarm:	Setting at 0~100% of rated current Automatic
	adjusting	power
	function:	50~100%

INTERNAL HEAT GENERATED

Internal heat generated by series PAC36P at maximum current operation is as follows. The heat decreases is proportional to the current decrease. Ventilation should be considered for the system

Rating current (A)	20	30	45	60	90	135	180	240	300	450	600
Internal heat generated (W)	82	121	151	196	274	442	620	731	1040	1567	2000

Approx. 10% more heat is generated in case of using rapid fuse.



บริษัท เอดีดี เฟอร์เนส จำกัด

ADD FURNACE CO.,LTD.

44 ซอยบรมราชชนนี 70 ถนนบรมราชชนนี แขวงศาลาธรรมสพน์ เขตทวีวัฒนา กรุงเทพฯ 10170

โทร: 02-888-3472 โทร: ออกแบบ:08-08-170-170 แฟกซ์: 02-888-3258

https://www.add-furnace.com E-mail: sales@add-furnace.com

ORDERING INFORMATION

Series PAC36P

Item	Code	Specification					
Series	PAC36P	Thyristor three- phase power regulator					
CONTROL INPUT	3	1-5V DC, Input Impedance: 200kΩ / contact signal					
	4	4-20mA DC, Receiving Impedance: 100Ω / contact signal					
	6	0-10V DC, Input Impedance: 200kΩ / contact signal					
	9	Others (Please consult before ordering.)					
POWER SUPPLY	15-	200-220V					
	16-	220-240V					
	17-	380-400V					
	18-	400-440V					
CURRENT CAPACITY (KVA is a guideline for rated load capacity)	Code		200V-240V	Code		400V-440V	
	021	20A	7/ 8kVA	022	20A	14/ 15KVA	
	031	30A	10/ 13kVA	032	30A	21/ 23KVA	
	041	45A	16/ 19kVA	042	45A	31/ 34KVA	
	061	60A	21/ 25kVA	062	60A	42/ 46KVA	
	091	90A	31/ 37kVA	092	90A	62/ 69KVA	
	131	135A	47/ 56kVA	132	135A	94/103KVA	
	181	180A	62/ 75kVA	182	180A	125/137KVA	
	241	240A	83/100kVA	242	240A	166/183KVA	
	301	300A	104/125kVA	302	300A	208/229KVA	
	*451	450A	156/187kVA	452	450A	312/343KVA	
*601	600A	208/249kVA	602	600A	416/457KVA		
FEEDBACK FUNCTION	0	Constant voltage (standard feature) / Nichrome					
	1	Constant current / Platinum, carbon, salt bath, tungsten					
	2	Constant power / SiC/Carbon (Note)					
	3	Voltage Square-root / Nichrome					
OUTPUT CONTROL FUNCTIONS	0	None					
	1	Startup time output control limiting (0-60%, 1-60sec.)					
	2	Current limit (when saving continuously for more than 1 minute)				Not selectable when 1 or 2 is selected with the feedback function	
	3	Startup time output control + Current limiting					
EXTERNAL POWER ADJUSTER	WHEN USED WITH VOLTAGE AND CURRENT OUTPUT CONTROLLER	N	None (Internal installation as standard)				1 set (knob/scale plate/lead)
		P	External power adjuster				
		M	Manual power adjuster				
		B	Base power adjuster				
		W	External power + Manual power				
	Y	External power + Base power					
	WHEN USED WITH CONTACT OUTPUT	P	External power adjuster				1 set (ditto)
		H	High-Low power adjuster				2 set (ditto)
HEATER BREAK ALARM (constant resistance load)	0	Without					
	1	With (0-100% setting of rated current)					
RAPID FUSE	0	Without					
	1	With (See rapid fuse table.)					
AUTO POWER ADJUSTMENT FUNCTIONS	0	Without					
	4	4-20mA DC, Receiving Impedance: 100Ω					
	6	0-10V DC, Input Impedance: 200kΩ					
REMARKS	0	Without					
	9	With (Please consult before ordering.)					

• Please contact us when using other than the rated voltage.

• The 200V series/450A, 600A and 400V series/20 to 600A marked with * are treated as semi-standard products. Please contact us in advance for the delivery date.

(Note) For constant power output, the rated voltage x 1/2 of the rated current is 100% power value. That is, select a thyristor rating twice the load

■ External adjuster

Code	Specification
QSV002	B10kΩ, knob, scale plate, 1m lead

■ RAPID FUSE (Option)

CURRENT CAPACITY	FUSE CAPACITY	PARTS NO.
20A	30A	CR6L-30S
30A	40A	500GA-40S
45A	60A	500GA-60S
60A	100A	500GB-100S
90A	120A	500GB-120S
135A	200A	CS5F-200
180A	250A	CS5F-250
240A	350A	CS5F-350
300A	450A	CS5F-450
450A	600A	CS5F-600
600A	800A	CS5F-800

CR6L, CS5F / Made by Fuji Electric Co., Ltd.

500GA, 500GB / Made by Hinode Electric Co., Ltd.



DRAWING OF ADDITIONAL FUNCTION CHARACTERISTIC

Series PAC36P

• Automatic Power Adjusting Function

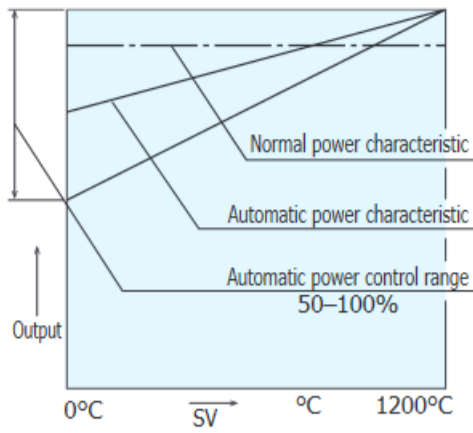

The maximum output (power) suitable for the set (SV) temperature is set steplessly by an external signal (program controller, computer, controller), and controllability over a wide area is improved.

• Power Linear Characteristics (Voltage Feedback)

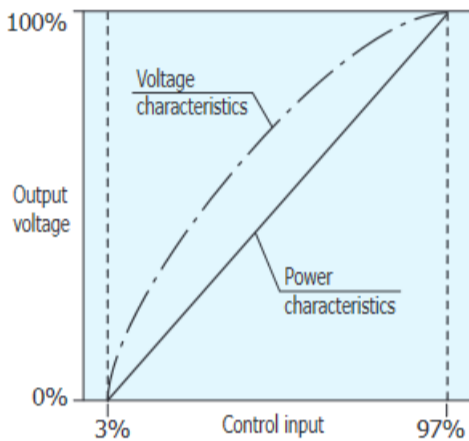

This function outputs a power proportional to the control input and also has a constant voltage characteristic, so it can be applied to a nichrome heater to improve controllability. It becomes a power regulator proportional to the scale of the regulator for manual adjustment.

• Current Limiting Characteristics

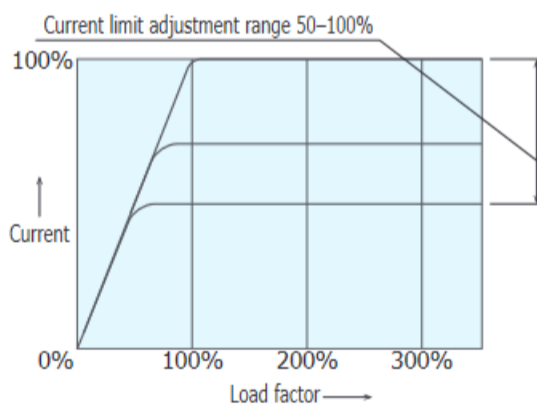

This function is a characteristic that limits the current value to the set value (50 to 100% of the rated value). Select this when controlling the heater such as platinum, molybdenum, tungsten, etc. where an initial inrush current occurs and the SiC heater control.

Note: With this characteristic, the power is reduced as the load is increased beyond the rating. (See table below)

Load factor	100%	200%	300%	500%
Current	97%	100%	100%	100%
Voltage	97%	50%	33%	20%
Power	94%	50%	33%	20%

• Constant Current Characteristics (Current Feedback)

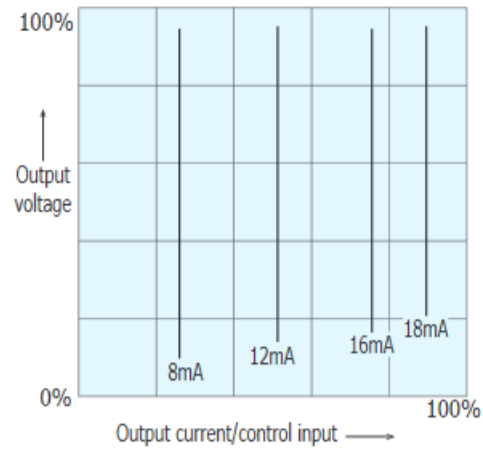

This function calculates and controls the current setting value given by the control signal and the current signal from the current transformer (built-in CT). If the control input is constant, the current is controlled to be constant even if load fluctuations and power supply fluctuations occur, making it suitable for controlling platinum, molybdenum, tungsten, Kanthal super, etc.

• Constant Power Characteristics (Power Feedback)

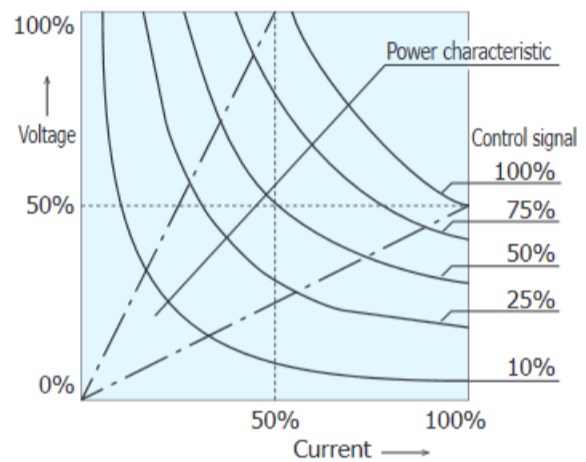

This function controls the electric power proportional to the control input, and its effect appears in the SiC heater control where the resistance value changes greatly depending on the temperature range. Controlling the electric power controls the amount of heat generated in a stable manner, and the controllability is further improved compared to the case of controlling only the voltage or current. When selecting this characteristic, it is necessary to allow some extra thyristor capacitance. The maximum power characteristics of the thyristor are in the range of rated current 50% × rated voltage 100% to rated current 100% × rated voltage 50% as shown in the figure above. Select the thyristor rating so that the heater load current used is 50% of the thyristor current shown in the above figure.

• Start up Output Limiting Characteristics

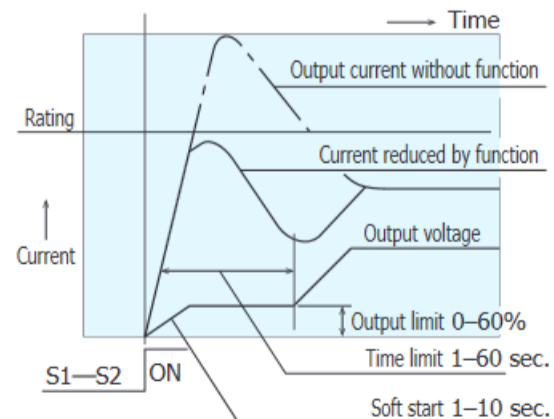

This characteristic is effective when controlling a load (platinum, molybdenum, tungsten, infrared lamp, etc.) that has an inrush current when the power is turned on or when the load is switched. It can also protect the load.



DRAWING OF ADDITIONAL FUNCTION CHARACTERISTIC

Series PAC36P

• Output Power

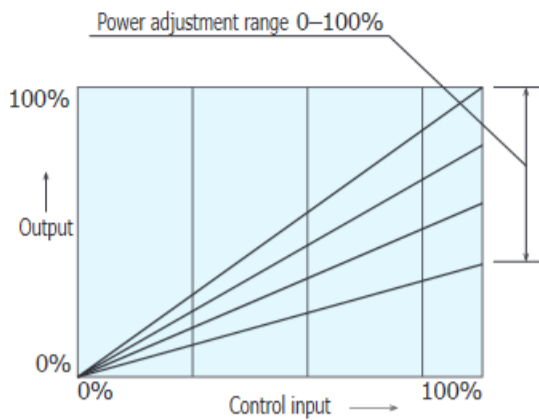

This function selects the external power when you want to operate it away from the main unit. It can be used to adjust the power to suit the set temperature, improve controllability, adjust the rising slope, and manually correct the load characteristics.

* When combined with a voltage/current input type controller, the internal power (with standard) can be used in the same way as above.

• High / Low Power Characteristics

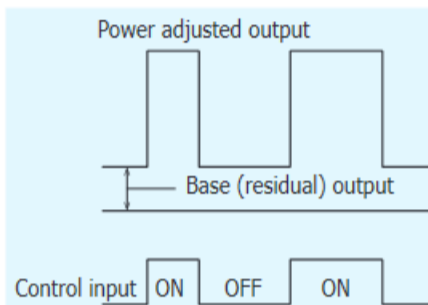

In the case of contact signal input type, use low power to improve control and prevent inrush current due to load characteristics in combination with two-position controller or PID controller. High power can adjust the power in the range of 0 to 100% when the C1 and C2 terminals are short-circuited. The low power is the output value that is obtained by multiplying the low power adjustment value by the high power adjustment value when C1 and C2 terminals are released.

Example: When the high power value is 80% and the low power is 30%, the residual output is 24%

• Base (Residual) Power Characteristics

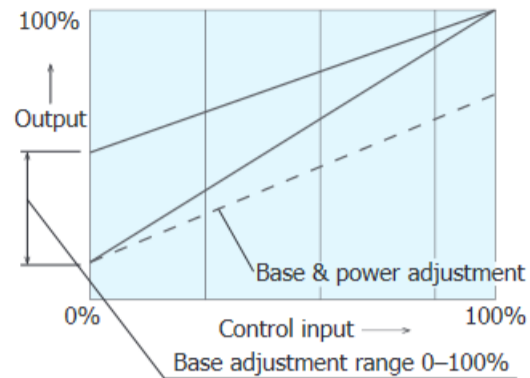

In general control, the output is set to 0% when the control input is 0%, but when the output limit function at startup is added, the control input continues for 0% of the time, and when the heater temperature falls, the control input is turned on again. When it increases to 100% etc., an appropriate current remains so that an overcurrent does not flow.

*The residual output can be adjusted in the range of 0 to 100%, so be careful to set it to the required value so that it does not become excessive.

• Heater Break Alarm Circuit

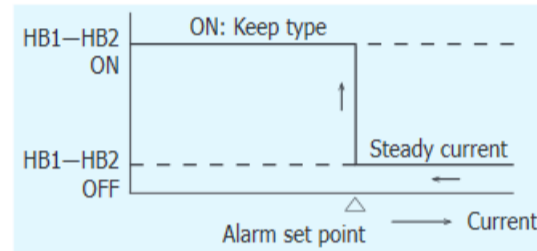

The load current is detected, the load current is compared with the alarm set point, and an alarm is output if the load current is below the set value.

The heater burnout alarm function calculates by voltage/current detection, and the detection sensitivity is about 10%.

*Reset: Power OFF

*Control output is output even during alarm operation

CHARACTERISTICS OF HEATING ELEMENT

The heating element has the characteristics as shown in the table below.

Infrared lamp load requires start-up output limiting function.

Loads with large thermal capacity such as Platinum, Molybdenum, Tungsten and Kanthal Super require the addition of a current limit function

Classification		type	Maximum operating temperature	Resistance - temperature characteristics	Additional function
Constant resistance load	Alloy	<ul style="list-style-type: none"> Nichrome Iron · chrome Graphite Kanthal A 	1100 °C (in the air) 1200 °C (in the air) 1330 °C (in the air)		<input type="checkbox"/> It is a general feature. It is possible with standard specifications.
		Variable resistance load	Pure metal	<ul style="list-style-type: none"> Tungsten Molybdenum Platinum Kanthal Super 	2400 °C (In vacuum) 1800 °C (In vacuum) 1400 °C (In vacuum) 1700 °C (in the air)
	Silicon carbide		<ul style="list-style-type: none"> Tecorandum Siliconit Elema 	1600 °C (in the air) 1600 °C (in the air) 1600 °C (in the air)	



EXAMPLE OF THE AUTOMATIC POWER FUNCTION

Series PAC36P

The automatic power function is a power adjusting function that provides suitable control output to the thyristor by external equipment (programmable controller, computer or controller) and improves controlling ability continuously providing suitable power to the SV (Set Value)

■ Constant value control

- Output with automatic power control function and result of control

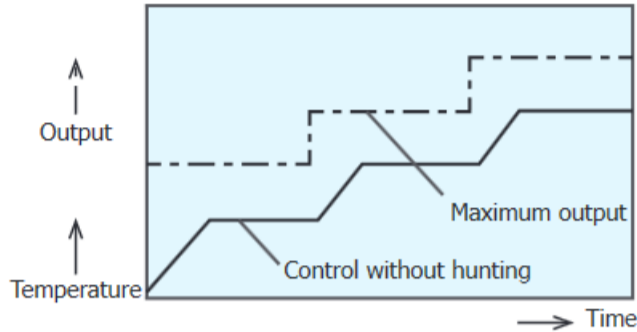

Power changes along with the SV value to prevent overshooting and allow optimum control.

■ Program Control

- Output with automatic power control function and result of control

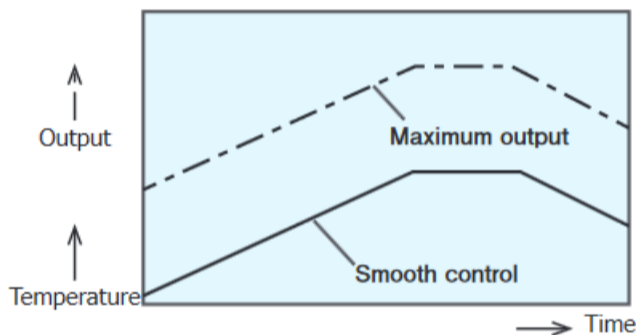

Soft control of the program is possible without transient characteristic (overshooting) at the start time.

- Output without automatic power control function and result of control

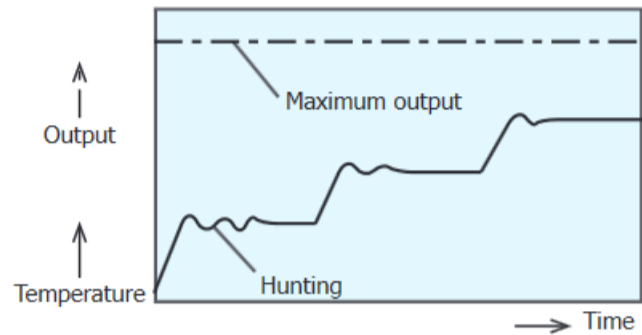

The power gets excessive in low range, resulting in overshooting and hunting

- Output with automatic power control function and result of control

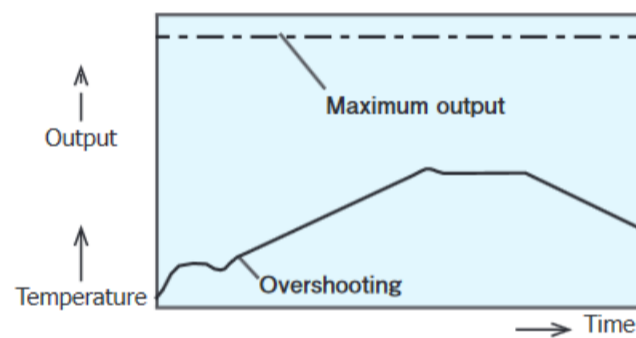

Power gets excessive at the start time, resulting in overshooting. In some cases, control characteristics deteriorate in a low range.

■ Procedure for Automatic Power Adjusting Function

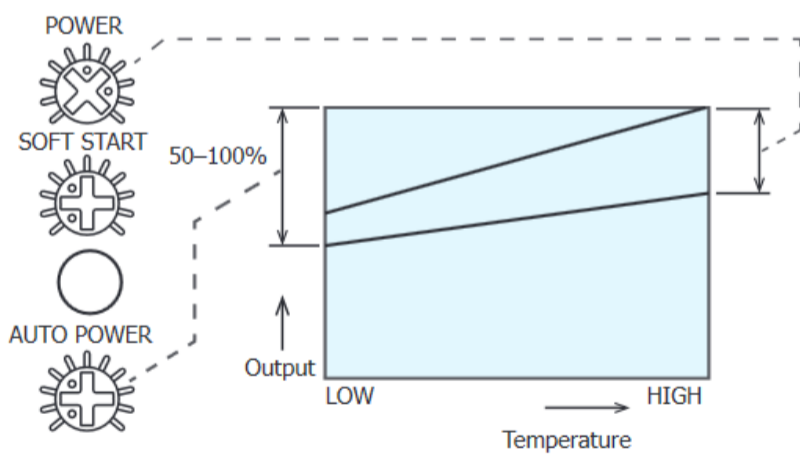

By setting output optimum to the low range set value on the [AUTO-POWER] adjuster, the output characteristic is designated to the line connecting automatic power adjusting value and the output at the maximum temperature. In case of adjusting maximum output, adjusters for internal power and external power are employed.

• Soft Control by Automatic Power Adjusting Function

In case of achieving small temperature stress such as bio industry and fine ceramic manufacturing, the automatic power adjustment is effective for precision control. The temperature control range expands for the same PID value in the PID control condition.

■ Example of combination with Digital controller SR23

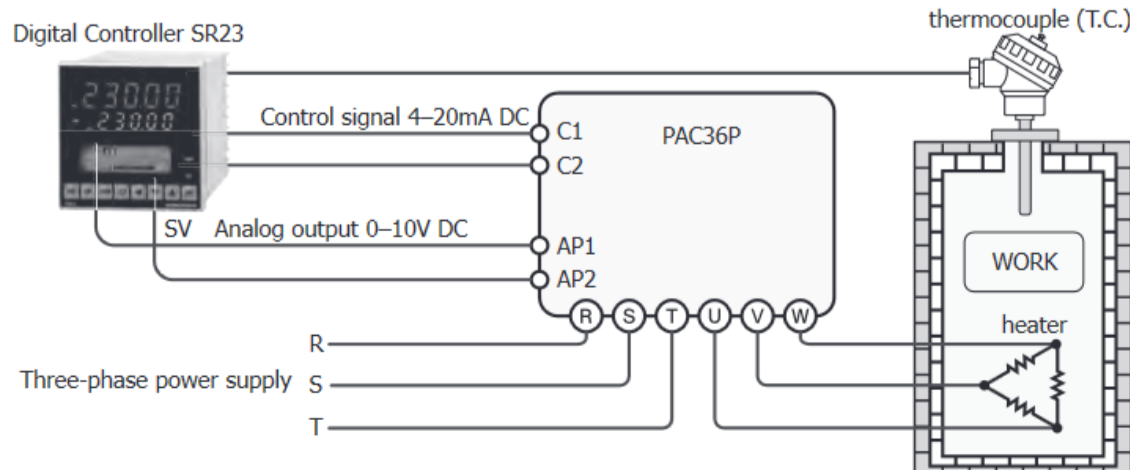

When the SV analog output (4–20mA or 0–10V) of the SR23 Digital controller is input to the auto power terminals (AP1 and AP2) of the PAC36P, maximum power cramping, is set automatically by controller setting (SV) and the efficiency of control is improved. The combination plays another role; it effectively saves a total load when several thyristors are turned on simultaneously. AP1-AP2.



PANEL INFORMATION AND CONTROL TERMINALS

Series PAC36P

Terminal No.	Code	Terminal code
Upper terminal	1	C1 (+)
	3	C2 (-)
	5	R1
	7	R2
	9	R3
	11	—
	13	M
	15	AL1
	17	AL2
Lower terminal	2	S1
	4	S2
	6	CL1
	8	CL2
	10	CL3
	12	AP1
	14	AP2
	16	HB1
	18	HB2
	20	G

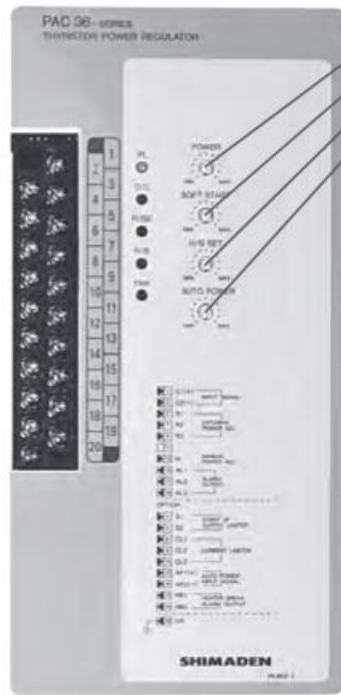

- Adjusters
 - Internal power adjuster (standard)
 - Soft start time adjuster (standard)
 - Heater break alarm setting device (option)
 - Automatic power adjuster (option)
- Monitor Lamps
 - P.L..... : Power supply
: Green LED turns on at correct phase sequence.
: Red LED turns on at open / opposite phase sequence.
 - O.C. : Over-current
 - Fuse : Burning-out of rapid fuse (option)
 - H / B : Heater break alarm (option)
 - FAN : Stoppage of cooling fan (standard for 180A or above)
- Terminal Codes and Functions
 - C1-C2 : Control input
 - R1-R2-R3 : External power (option)
 - M..... : Manual / base adjustment (option)
 - AL1-AL2-AL3..... : Alarm output common to over-current, FAN and FUSE
 - S1 - S2..... : External sequence signal for start up time output control limiting
 - CL1-CL2-CL3..... : Current limiting adjuster
 - AP1-AP2 : Automatic Power signal input
 - HB1-HB2..... : Heater break alarm output

CIRCUIT BLOCK AND WIRING OF CONTROL TERMINAL

● Circuit Block

● Additional Function (Option) (Lower Terminal)

Additional function terminals (Lower Terminal) are manufacturer options and cannot be added after delivery. Please select after ordering.

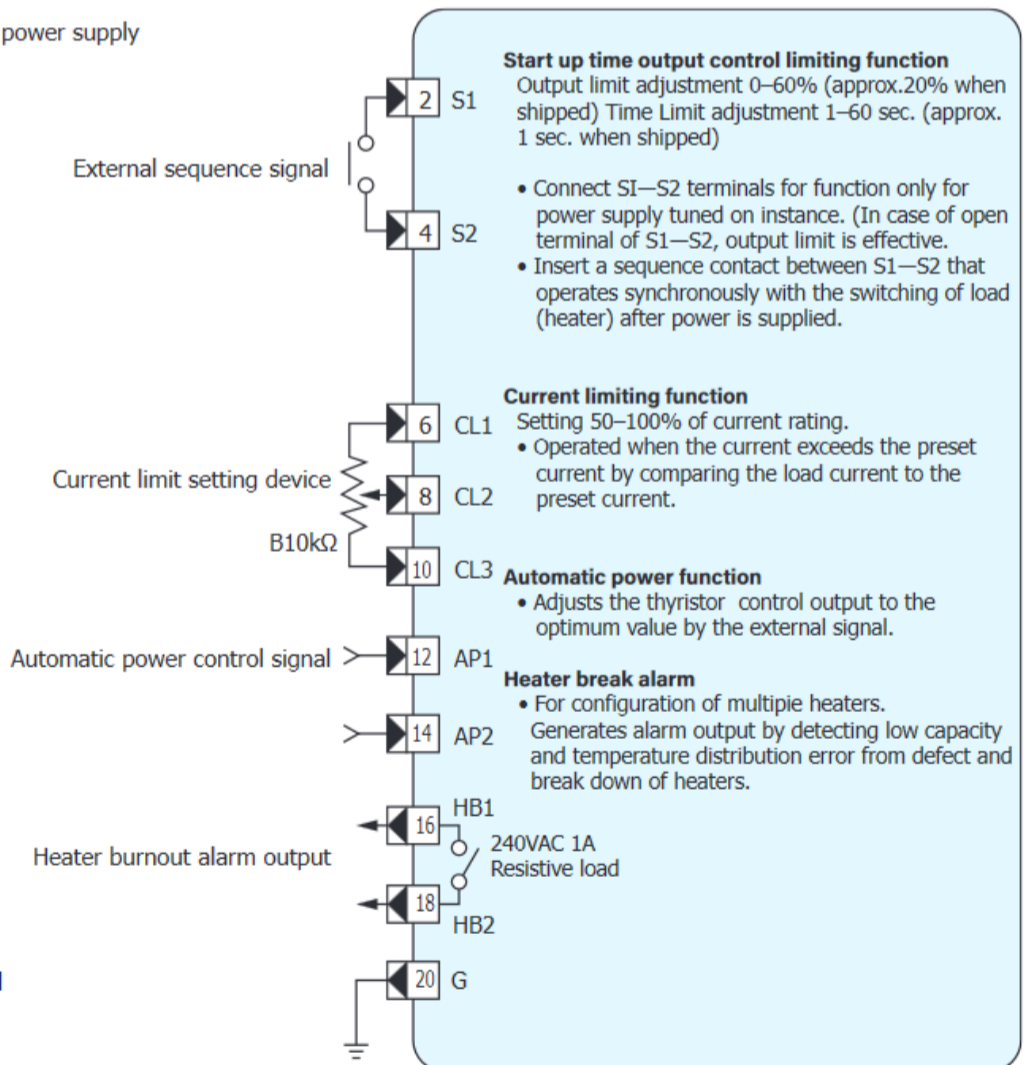
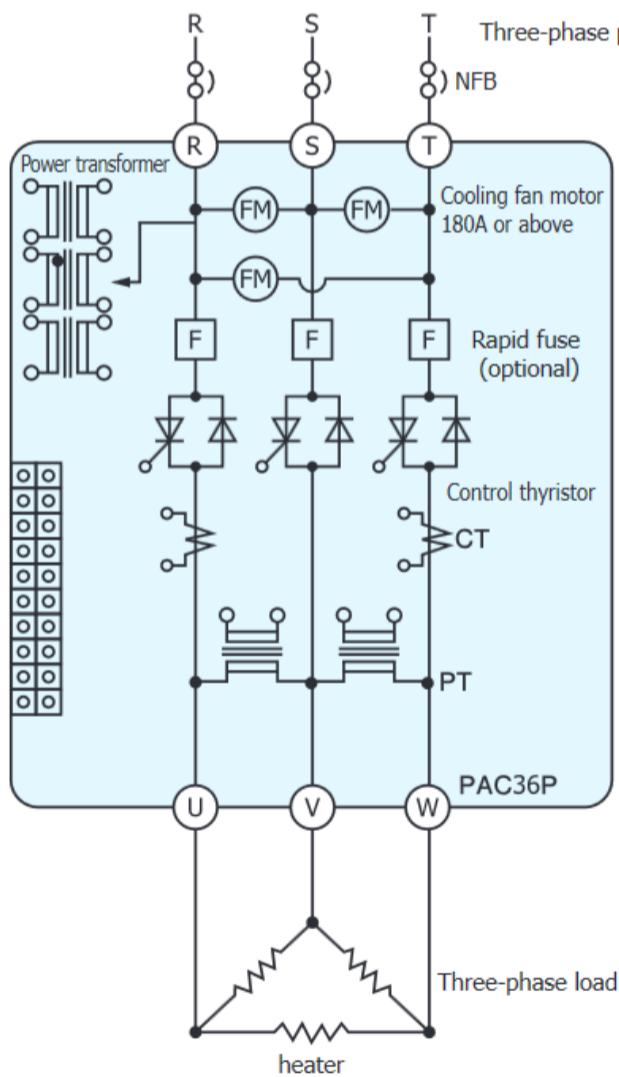



CIRCUIT BLOCK AND WIRING OF CONTROL TERMINAL

Series PAC36P

● Output Adjusting Function (Upper Terminal)

This function is available by connecting adjuster (rating B 10kΩ 1W), after delivery.

■ Wiring with contact output controller

External power

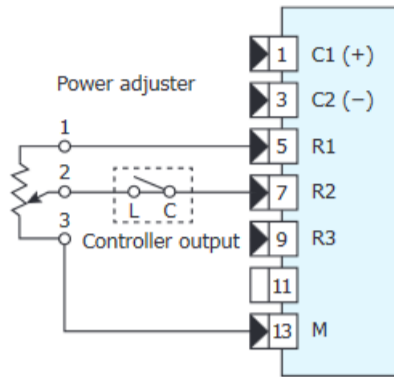

- To adjust output of contact ON (Controller output contact C-L conducted).
- Conduct ON: 0–100%

High / Low power

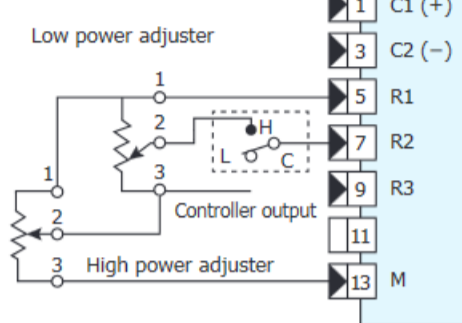

- To adjust maximum output for conducted (on) output contact C-L and to maintain non-conduct (off) (C-H conducted) output.
- High power: With C-L on 0–100%
- Low power: With C-H on High power x Low power

■ Wiring with voltage / current output controller

External power

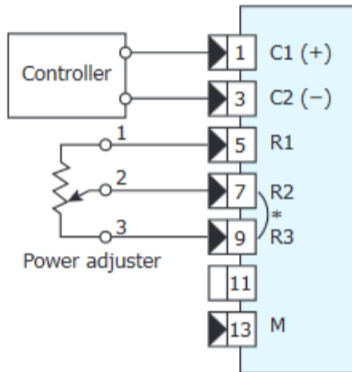

- Internal power adjuster as standard
- *When not using the power adjuster, short-circuit between R2 and R3. (Adjust with built-in power adjuster).
- Input of 100%: 0–100%

Manual power

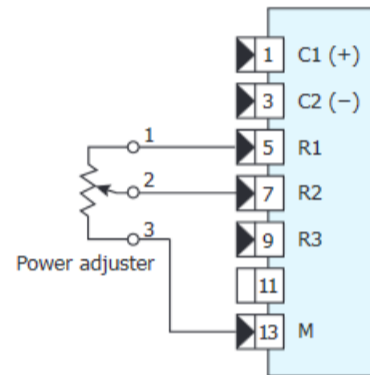

- To adjust power manually

Base (residual) power

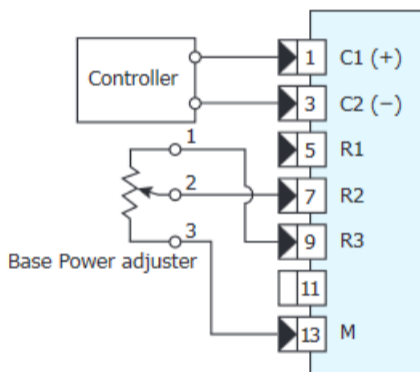

- To keep output steady when the control signal is at 0%.
- The maximum power is adjusted by internal power adjuster.
- Input of 0%: 0–100%

External power + Manual power (auto / manual)

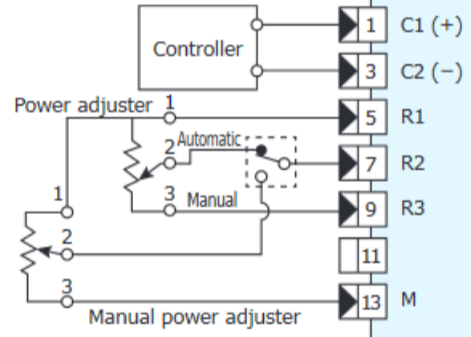

- External contact switches automatic / manual for power adjusting selection of automatic and manual operations.
- Please prepare the automatic / manual switch.

External power + Base (residual) power

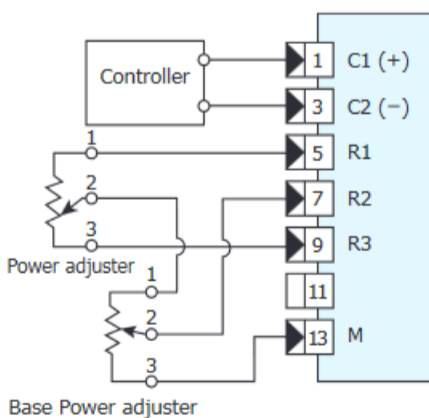

- To adjust maximum output and to maintain some parts of output of 0% control signal.

Alarm circuit

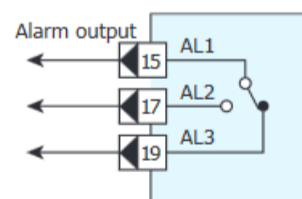

- Alarm output. Conduct between AL1 and AL2. Non conduct between AL1 and AL3.
- Operation Over-current protection circuit on operation. Fuse burnt out. Cooling fan stopped.



บริษัท เอดีดี เฟอร์เนส จำกัด

ADD FURNACE CO.,LTD.

44 ซอยบรมราชชนนี 70 ถนนบรมราชชนนี แขวงศาลาธรรมสพน์ เขตทวีวัฒนา กรุงเทพฯ 10170

โทร: 02-888-3472 โทร: ออกแบบ:08-08-170-170 แฟกซ์: 02-888-3258

https://www.add-furnace.com E-mail: sales@add-furnace.com

EXTERNAL DIMENSION, WEIGHT, MOUNTING

Series PAC36P

■20A

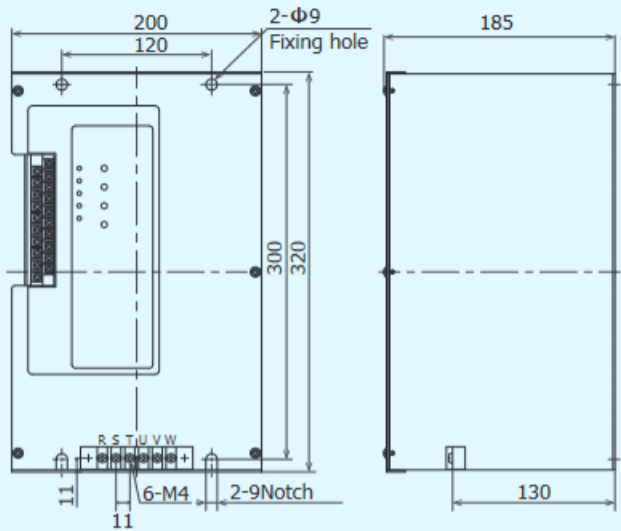

Weight: approx. 9kg.

■30A / 45A

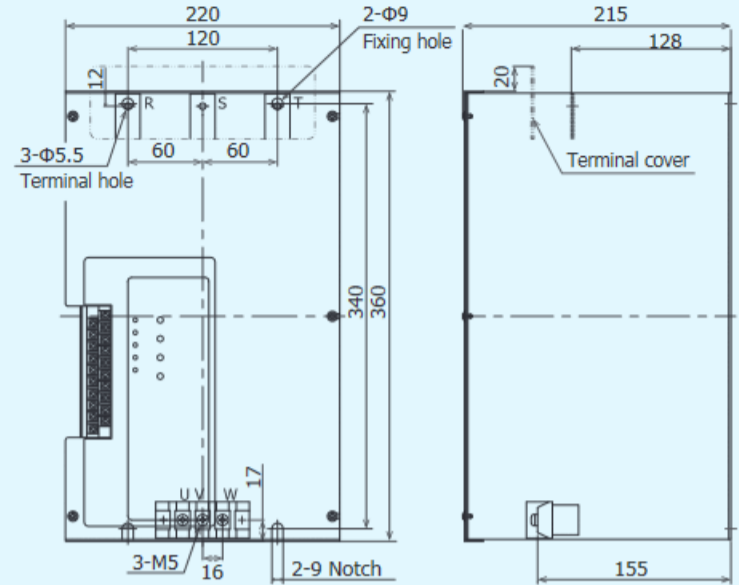

Weight: approx.12kg.

■60A / 90A

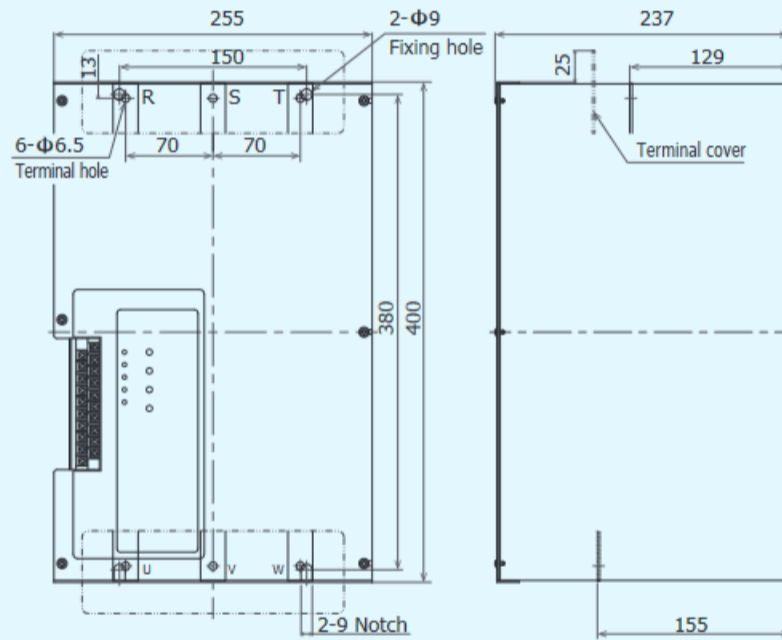

Weight: approx. 16.5kg.

■135A / 180A / 240A / 300A

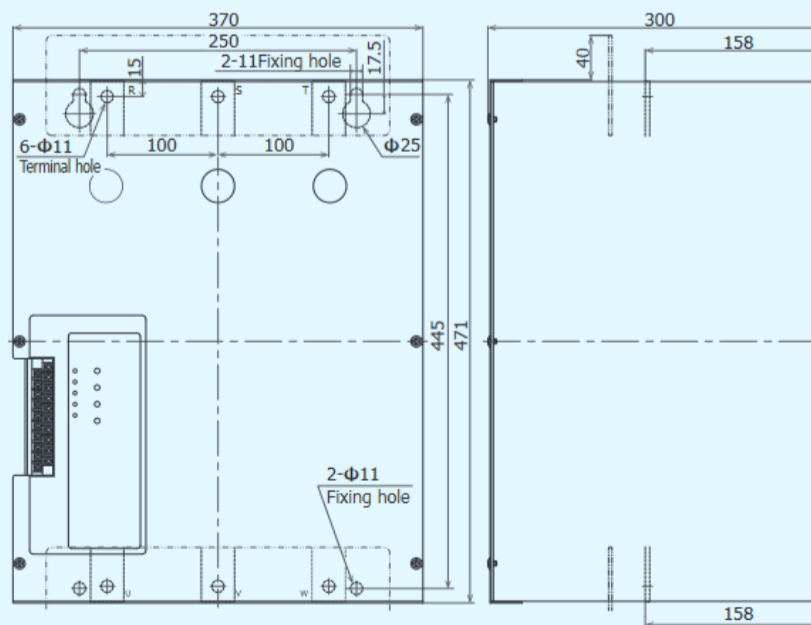

Weight: approx. 36.0kg.



บริษัท เอดีดี เฟอร์เนส จำกัด

ADD FURNACE CO.,LTD.

44 ซอยบรมราชชนนี 70 ถนนบรมราชชนนี แขวงศาลาธรรมสพน์ เขตทวีวัฒนา กรุงเทพฯ 10170

โทร: 02-888-3472 โทร: ออกแบบ:08-08-170-170 แฟกซ์: 02-888-3258

https://www.add-furnace.com E-mail: sales@add-furnace.com

EXTERNAL DIMENSION, WEIGHT, MOUNTING

Series PAC36P

Unit: mm

■450A / 600A

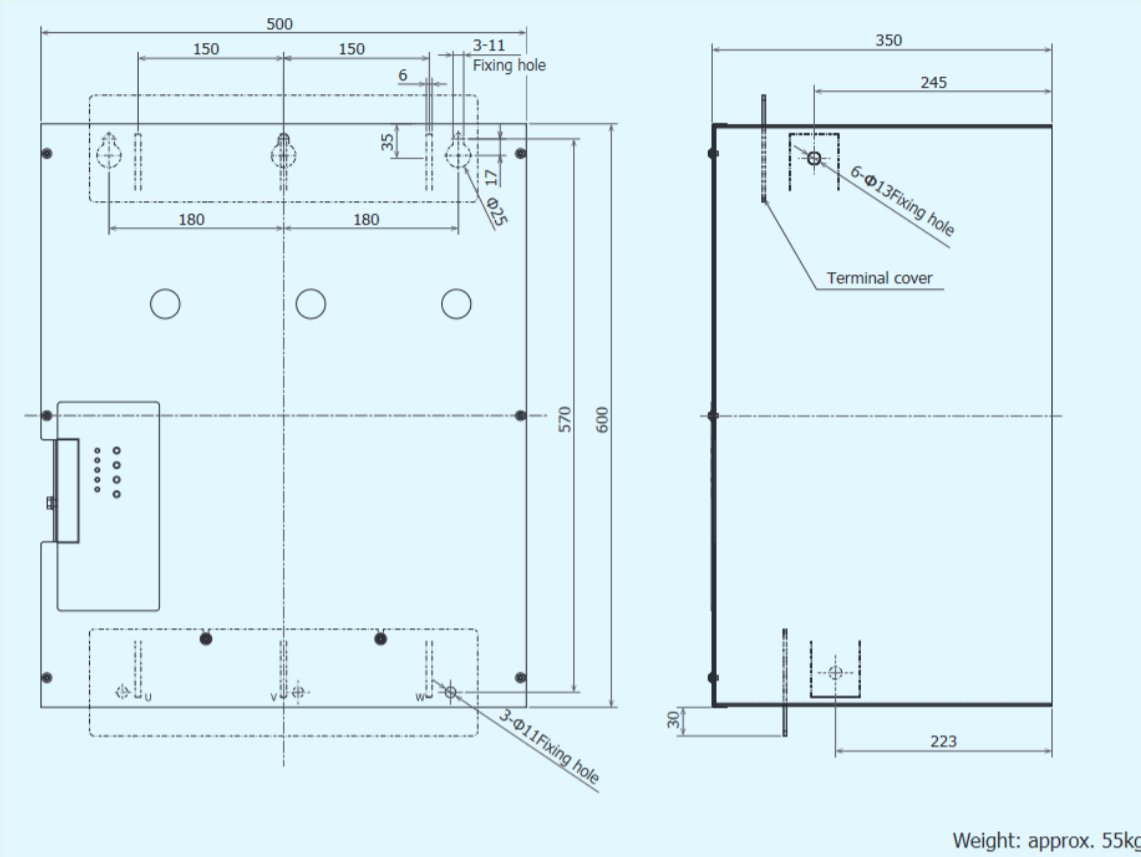

Weight: approx. 55kg.

■Mounting diagram

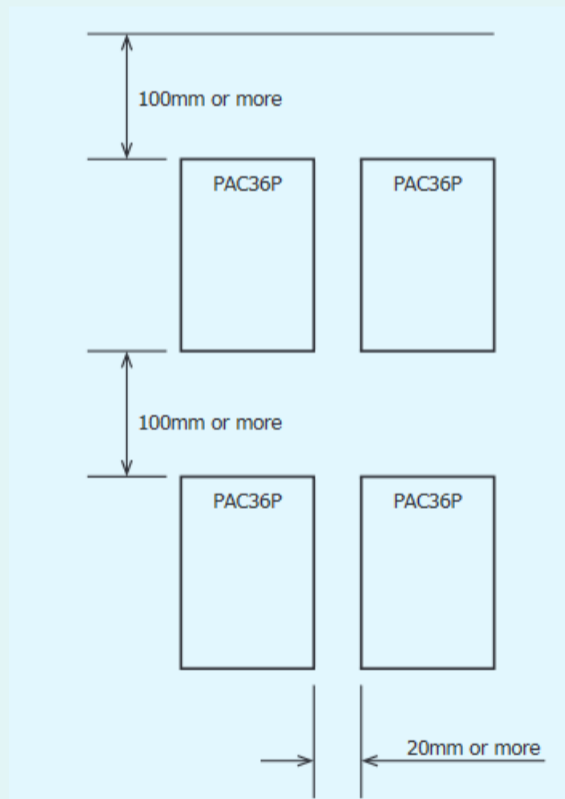



บริษัท เอดีดี เฟอร์เนส จำกัด

ADD FURNACE CO.,LTD.

44 ซอยบรมราชชนนี 70 ถนนบรมราชชนนี แขวงศาลาธรรมสพน์ เขตทวีวัฒนา กรุงเทพฯ 10170

โทร: 02-888-3472 โทร: ออกแบบ:08-08-170-170 แฟกซ์: 02-888-3258

https://www.add-furnace.com E-mail: sales@add-furnace.com

APPLICATION EXAMPLES

Series PAC36P

•Application Connecting a Conventional Heater

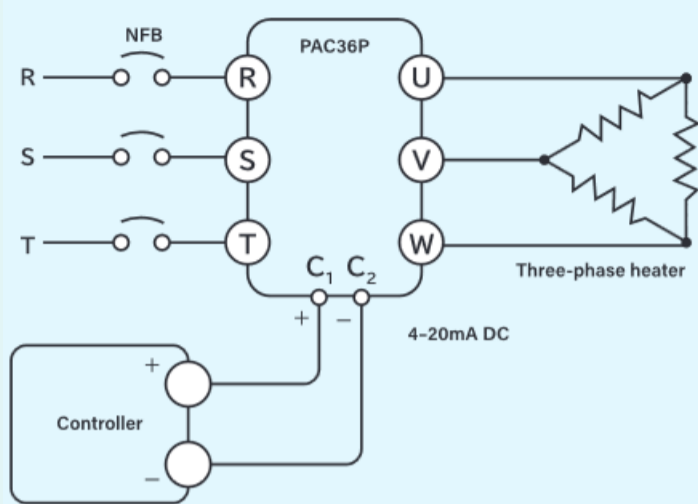

•Application with Transformer

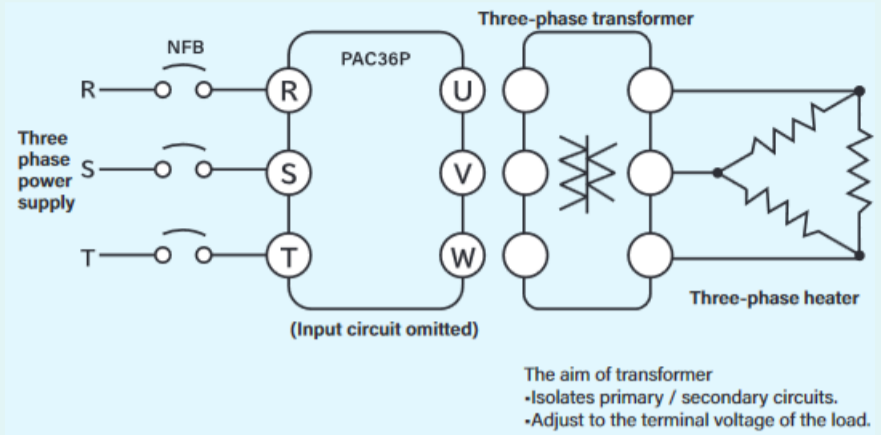

—Note for transformer design—

Generally, margin is set for magnetic flux density in application of switching controlling. The value of the magnetic flux density should be less than 8000 Gauss.

Avoid unbalance of load and rush current from magnetic saturation.

EXTERNAL POWER ADJUSTER

•Rating

Type: QSV002

Characteristics / Resistance: B 10kΩ 1W

M3.5 crimp terminal



•External dimensions and mounting method

Lead wire: With 1m vinyl lead

Scale version/Knob.....with 1 each

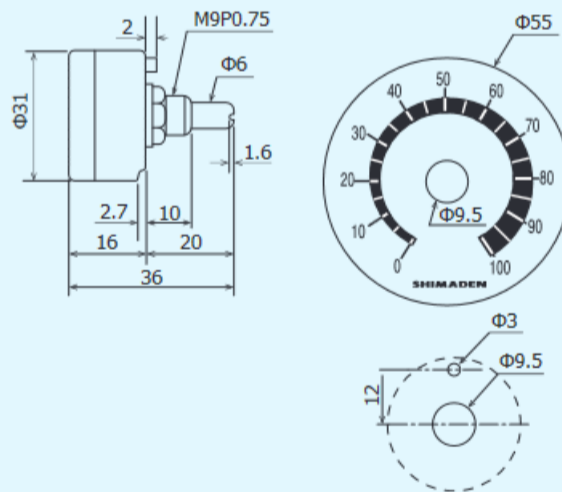

•Names and scale

External power 0-100%
 Manual power 0-100%
 Base power 0-100%
 High/low power 0-100%
 Current limit setter (QSV004) ... 50-100%



NOISE COUNTERMEASURE

Series PAC36P

In a thyristor, especially in phase control, a part of the sine wave waveform of the power supply is cut out before use, which causes distortion of the power supply waveform when the power supply impedance is high. Also, since the power supply is switched every half cycle, switching noise is generated.

These power distortions and noise may affect other equipment, so use a noise filter if necessary.

How to use the noise filter: Three-phase three-wire

Note) Install the noise filter on the same metal plate as PAC36P and be sure to ground it.

Make the wiring between the noise filter and PAC36P as short as possible.

1) One-phase installed power supply (Delta connection)

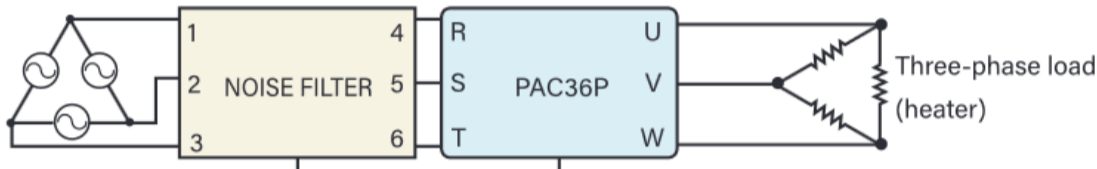

2) Neutral point ground power supply (star connection)

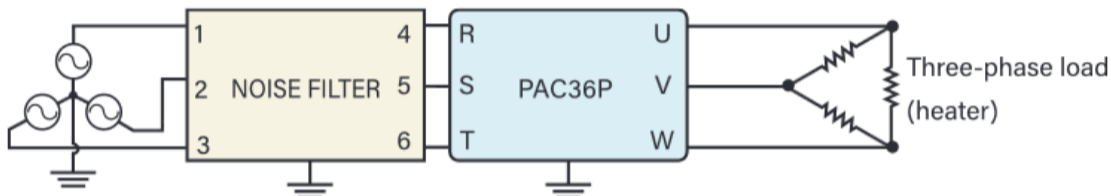

■ Noise filter (sold separately)

The frequency component of the noise generated by the thyristor is distributed in the low place below a few MHz,

General-purpose general-purpose noise filters do not have sufficient noise attenuation effect.

Noise can be attenuated by using our designated noise filter.

This noise filter is dedicated to our thyristor power regulator.

CURRENT	CAPACITY Code
20A	NF3020C-SXJ
30A	NF3040C-SXK
45A	NF3050C-SXK
60A	NF3060C-SXK
90A	NF3100C-SXK

CURRENT CAPACITY	Code
135A	NF3150C-SXK
180A	NF3200C-SXK
240A	NF3300C-SXK
300A	NF3300C-SXK
450A	NF3500C-SXK
600A	NF3600C-SXK