

SIEMENS

7 636



VGG...

VGf...

Gas Valves

VGG...

VGf...

- Single valves of class A for installation in gas trains
- Safety shutoff valves conforming to EN 161 in connection with actuators
- Suitable for use with gases of gas families I...III
- Gas valves in connection with actuators open slowly and close rapidly
- 2-port valves of the normally closed type
- 1/2" ... DN80
- The gas valves are used in combination with the SKPx5 actuators
- As a control valve in connection with SAX31 actuators and AGA60 adapter (not as a safety shutoff valve)
- As a control valve in conjunction with AGA61, not as a safety shutoff valve
- Supplementary Data Sheets on actuators (see Mechanical design)

The VGx and this Data Sheet are intended for use by OEMs which integrate the gas valves in their products!

Use

The gas valves are used primarily

- for application at gas-fired combustion plant
- for gas trains at forced draft burners

The gas valve is used as:

- Shutoff valve (in combination with SKP15)
- Control valve with shutoff feature (in combination with SKP25, SKP55 or SKP75)
- As shutoff or control valves in the supply air line of industrial combustion plant with or without heat recovery system

If the gas valves are used with gases other than those of gas families I...III, Siemens assumes no responsibility for the valve's durability and life expectancy.

All types of gas valves can be combined with any of these actuators.

Warning notes



To avoid injury to persons, damage to property or the environment, the following warning notes must be observed!

- Do not open, interfere with or modify the gas valves
- Any opening of the gas valve, replacement of parts or modifications to the original product is the user's responsibility and carried out at his own risk
- All activities (mounting, installation and service work, etc.) must be performed by qualified staff
- When used in connection with gas, the gas valves constitute part of the safety equipment
- In combination with SAX31... / AGA61 actuators, the gas valves must **not** be used as safety devices
- Fall or shock can adversely affect the safety functions. Such gas valves must not be put into operation, even if they do not exhibit any damage
- Not suitable gases or gas components causes loss of the safety shutoff function
- It may not join contaminant/particles in the valve, because that could adversely affect the safety shutoff function

Engineering notes

Profile
 (only for VGGxx.xxxxP/
 VGFxx.xxxxP)

Owing to the profile of valve disc, the gas valves are especially suited for control functions.

Benefit:

Good control performance and hardly prone to hunting in low-fire range.

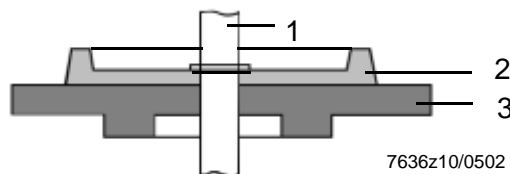

Legend

- 1 Stem
- 2 Profile
- 3 Valve disc

Mounting notes

- Ensure that the relevant national safety regulations are complied with
- The actuator can be mounted or replaced while the gas valve is under pressure
- Refer also to the following Mounting Instructions

AGA66	M7643.2	74 319 0421 0
VGF	M7636/M7631	431920720
VGF DN50...80	M7636.1/M7633	431920500
VGG	M7636/M7631	431920720
VGG 1/2" ...3"	M7636.1/M7633	431920500
VGx10.654	M7636.2	431923450
VGx10.804	M7636.2	431923450

Sealing/tightness

- Check to ensure that the gas valve is tight when all components are connected
- Check to ensure that the gaskets between the flanges and the gas valve must be fitted

Mounting position

The permissible mounting positions of the actuator must be observed, however (refer to the relevant Data Sheet).

Direction of flow

The direction of gas flow must be in accordance with the direction of the arrow on the valve body.

Function

The inactive gas valve is closed and opens when the actuator opens.

Only VGG

Check to ensure that cuttings not falling into the gas valve when mounting the connecting pipes.

Only VGF

Check to make certain that the bolts of the flanges are properly tightened and afterwards check to ensure that the gas valve is tight when all components are connected.

Standards and certificates



Note!
 Only in conjunction with SKPx5, see Data Sheet N7643.



EAC Conformity mark (Eurasian Conformity mark)



ISO 9001:2008
 ISO 14001:2004
 OHSAS 18001:2007



China RoHS
 Hazardous substances table:
<http://www.siemens.com/download?A6V10883536>

For USA/Canada versions, see data sheet N7636us.

For use in the U.S./Canada, the gas valves carry type suffix **U** (see example) and , and listed.

Example: VGG10.204U

Approvals in combination with actuator

Type reference			
VGG10.154P	●	●	---
VGG10.204P	●	●	●
VGG10.254P	●	●	●
VGG10.404P	●	●	●
VGG10.504P	●	●	●
VGG10.804P	●	●	●
VGG10.1541P	●	●	---
VGG10.2041P	●	●	---
VGG10.2541P	●	●	---
VGG10.4041P	●	●	---
VGG10.5041P	●	●	---
VGG10.8041P	●	●	---
VGf10.504P	●	●	---
VGf10.654P	●	●	●
VGf10.804P	●	●	●
VGf10.5041P *)	●	●	---
VGf10.6541P *)	●	●	---
VGf10.8041P *)	●	●	---

*) Only for replacement

Service notes

- Each time a gas valve has been replaced, check to ensure that the gas valve operates correctly and that it is tight both internally and externally
- Siemens gas valves may **only** be repaired by Siemens Repair Centers

Life cycle

The combination gas valve VGx and actuator have a designed lifetime* of

Nominal sizes	Burner startup cycles
≤25 DN	200.000
25...80 DN	100.000
80...150 DN	50.000

under use of gases to EN 437 (or DVGW specification G260). This lifetime is based on the endurance tests specified in standard EN 161.

A summary of the conditions has been published by the European Control Manufacturers Association (afecor - www.afecor.org).

The designed lifetime is based on use of the gas valve VGx and actuator according to the manufacturer's Data Sheet. After reaching the designed lifetime in terms of the number of burner startup cycles, or the respective time of usage, the gas valve and actuator are to be replaced by authorized personnel.

* The designed lifetime is not the warranty time specified in the Terms of Delivery

Disposal notes



Local and currently valid legislation must be observed.

Mechanical design

VGG / VGF

The gas valves are dead closed in combination with actuator.

Stem

The stem is guided on both sides of the valve disc, ensuring precise axial stroke and tight shutoff.

Strainer

A strainer made of stainless steel is fitted in the gas valve's inlet and protects the gas valve, the seat and disc as well as downstream devices against dirt.

Valve seat

For use with profile, the gas valves carry type suffix **P** (see example)

Example: VGG10.154**P**

Actuators

The gas valves can be combined with the following types of actuators:

Type reference	Data Sheet	Function
SKP15	N7643	ON/OFF
SKP25	N7643	ON/OFF with constant pressure control
SKP25.7 with SAS	N7643	ON/OFF with pressure control and via electric signal alterable setpoint setting
SKP55	N7643	ON/OFF with differential pressure control, signal input → differential pressure
SKP75	N7643	ON/OFF with ratio control, signal input → static pressure
SAX31 with AGA60	N4501	Steady position control, no function of safety shutoff

Type summary (other types of gas valves on request)

Nominal size	Material	Perm. operating pressure in kPa		Air flow rate at $\Delta p = 0.1 \text{ kPa} / \text{m}^3/\text{h}$	Number of connections		Type reference			
		Europe (to EN)	Other countries		Test point RP $\frac{1}{4}$ 2)	Pilot gas G $\frac{3}{4}$ 3)	With profile / without stroke limitation		With profile / with stroke limitation ¹⁾	
							Article no.	Type	Article no.	Type
Internally threaded to ISO 7/1										
½"	Aluminum die casting	120	120 (140)*	4,8	4	---	BPZ:VGG10.154P	VGG10.154P	BPZ:VGG10.1541P	VGG10.1541P
¾"	Aluminum die casting	120	120 (140)*	8,9	4	---	BPZ:VGG10.204P	VGG10.204P	BPZ:VGG10.2041P	VGG10.2041P
1"	Aluminum die casting	120	120 (140)*	13,3	4	---	BPZ:VGG10.254P	VGG10.254P	BPZ:VGG10.2541P	VGG10.2541P
1 ½"	Aluminum die casting	60	60 (140)*	32,3	4	---	BPZ:VGG10.404P	VGG10.404P	BPZ:VGG10.4041P	VGG10.4041P
2"	Aluminum die casting	60	60 (140)*	47,4	4	---	BPZ:VGG10.504P	VGG10.504P	BPZ:VGG10.5041P	VGG10.5041P
3"	Gray cast	60	60 (70)*	85,4	2	2	BPZ:VGG10.804P	VGG10.804P	---	---
* Only for use in Australia										
With flange, PN16, to ISO 7005										
DN50	Gray cast	60	60	47,4	4	---	BPZ:VGF10.504P	VGF10.504P	BPZ:VGF10.5041P ⁴⁾	VGF10.5041P ⁴⁾
DN65	Gray cast	60	60 (70)*	74	2	2	BPZ:VGF10.654P	VGF10.654P	BPZ:VGF10.6541P ⁴⁾	VGF10.6541P ⁴⁾
DN80	Gray cast	60	60 (70)*	85,4	2	2	BPZ:VGF10.804P	VGF10.804P	BPZ:VGF10.8041P ⁴⁾	VGF10.8041P ⁴⁾
* Only for use in Australia										



The following types are only available on request: VGG10.1541U, VGG10.2041U, VGG10.2541U, VGG10.4041U and VGG10.5041U

Legend (also see Dimensions)

- 1) Cannot be used with attached pressure governor
- 2) On inlet and outlet side
- 3) Inlet side, VGF with one connection on each side
- 4) Only for replacement

Ordering

When ordering, please give the complete gas valve type reference.

Actuator and gas valve are supplied as single packs.

Example:

1 piece VGF10.654P flanged valve DN65 with profile
1 piece actuator

Accessories



Manual adjuster **AGA61**
Article no.: **BPZ:AGA61**



Adapter for SAX31... actuators

AGA60
Article no.: **BPZ:AGA60**

Consisting of 2 stem parts and a connecting flange

Gasket kit to SKPx5

AGA66
Article no.: **BPZ:AGA66**



- Between actuator SKPx5 and gas valve
- For increasing of degree of protection from IP54 up to IP65
- Refer to Mounting Instruction M7643.2 (74 319 0421 0)

Only VGG10.154, VGG10.204, VGG10.254, VGG10.404:

When used in connection with AGA66, the maximum flow rates are reduced by about 25%.

Technical data

General unit data

Valve class in connection with actuator	A conforming to EN 161 (except with SAX31 / AGA61)
Group	2 (EN 161)
Perm. medium temperature	0...60 °C
Weight	See Dimensions
Connecting flanges (VGF)	PN16 to ISO 7005-2
Required flow rate	See Flow chart
Perm. mounting position	

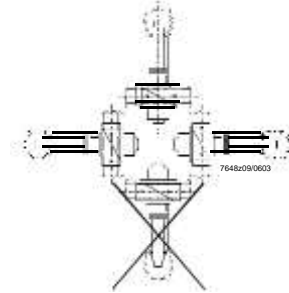

(see Mounting notes)

Operating pressure	See Type summary
Types of gases	See Use
Type of gases	Suited for gas of gas families 1, 2, 3 and air
Strainer (only for VGG/VGF)	Built-in, mesh size 0.9 mm

Environmental conditions

Storage	DIN EN 60721-3-1
Climatic conditions	Class 1K3
Mechanical conditions	Class 1M2
Temperature range	-20...+60 °C
Humidity	<95% r.h.
Transport	DIN EN 60721-3-2
Climatic conditions	Class 2K3
Mechanical conditions	Class 2M2
Temperature range	-20...+60 °C
Humidity	<95% r.h.
Operation	DIN EN 60721-3-3
Climatic conditions	Class 3K3
Mechanical conditions	Class 3M3
Temperature range	-10...+60 °C
Humidity	<95% r.h.
Installation altitude	Max. 2,000 m above sea level

Function

Sectional view of VGG

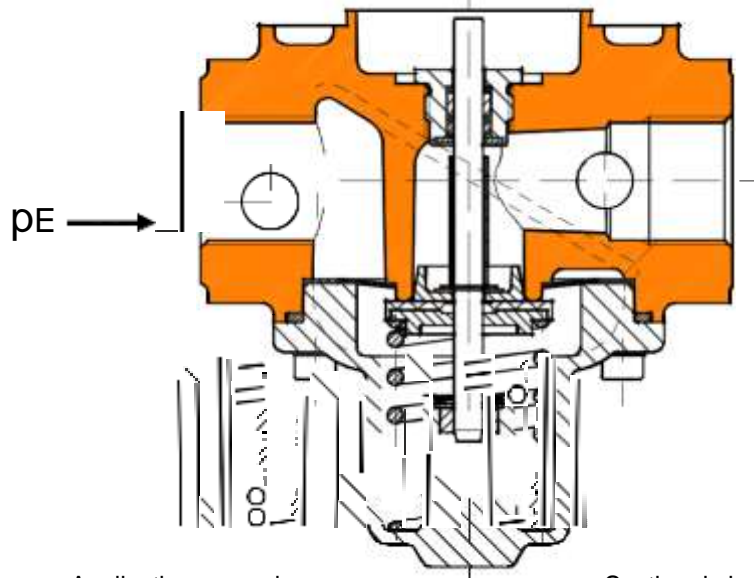

Application example
 VGG complete with SKP25

Sectional view
 VGG complete with SKP25

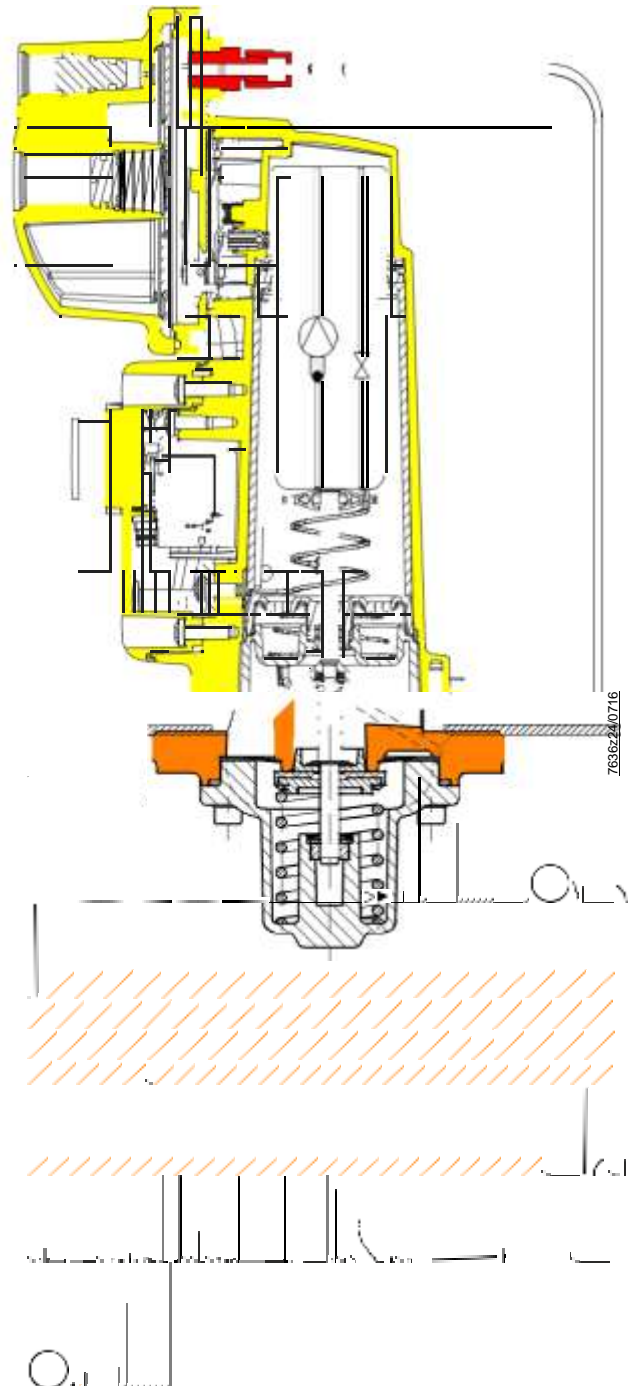

Function (cont'd)

Sectional view of VGF

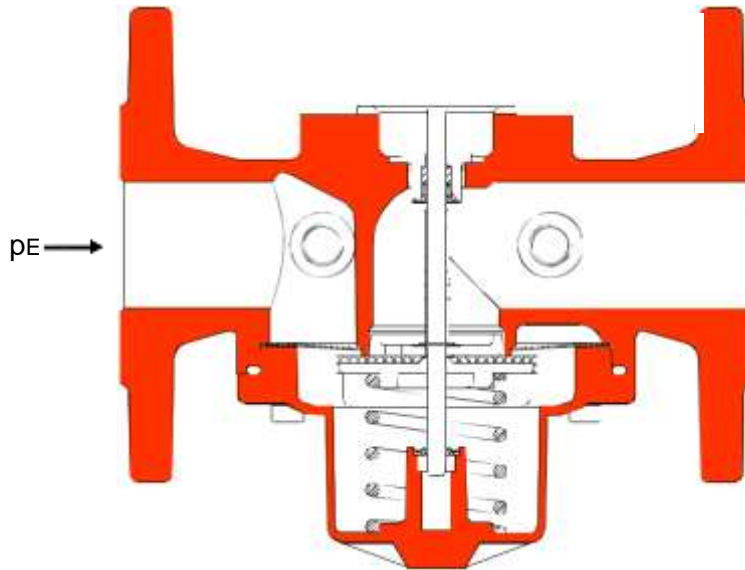

Application example
 VGF complete with SKP25



Sectional view
 VGF complete with SKP25

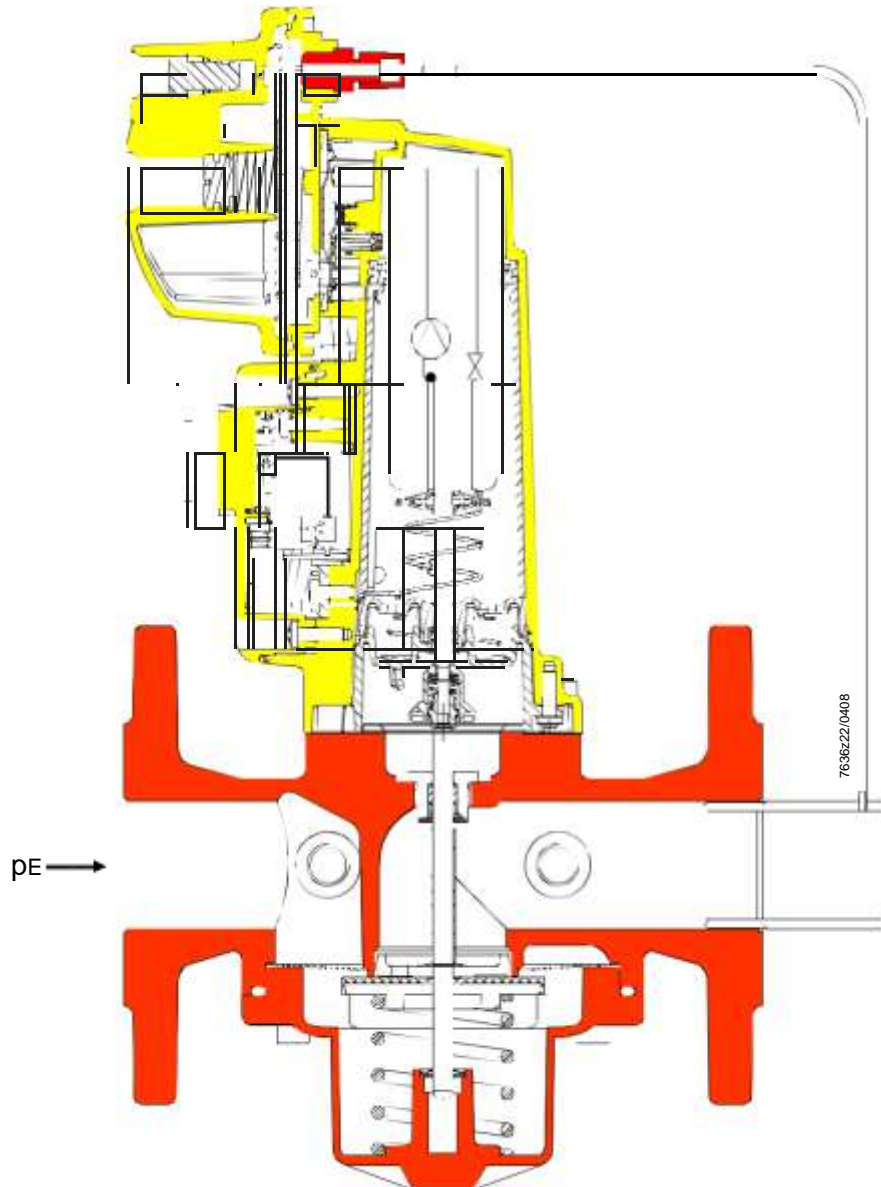

Flow chart (For fully open gas valves only)

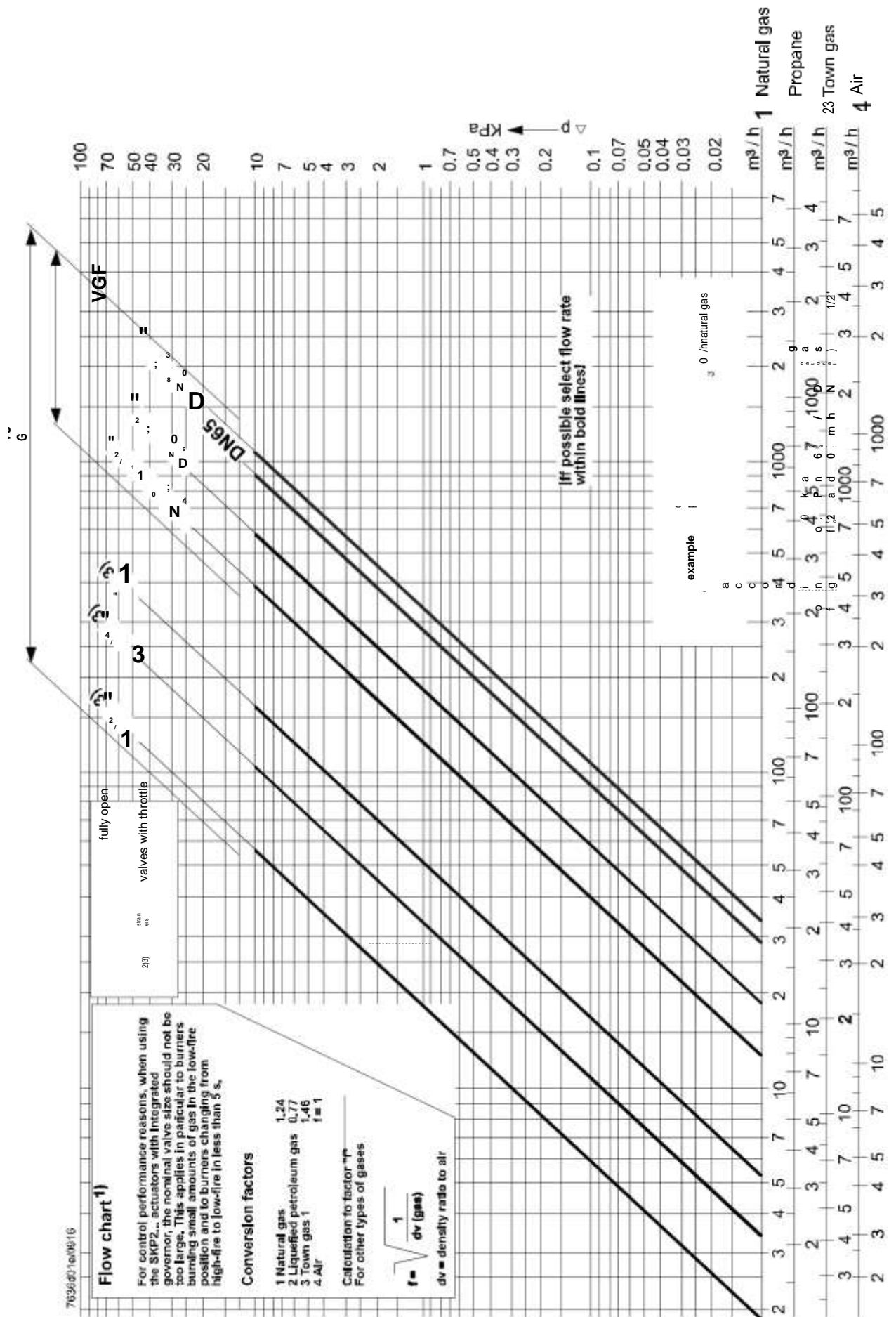

Flow chart (cont'd)

- Legend
- Maximum flow rate (gas valve fully open)
 - 1) The valve curves shown represent gas valves with no strainer. Each strainer reduces the flow rate by about 8%

The bold curves represent the recommended pressure drop ranges. Gas valves with higher pressure drops can cause excessive flow noise. Practical experience shows that applications outside the range confined by the bold characteristics could produce significant noise.

Caution!



- In the case of burners with low-fire flow rates, select a tightly sized gas valve (refer to the Data Sheet of the relevant actuator)
- If the available gas pressure exceeds the maximum permissible operating pressure, use an upstream pressure controller to lower it
- The pressure drop (curves of maximum flow) is based on a fully open gas valve

Conversion of air flow rate to a corresponding gas flow rate (natural gas):

Basis for scale

Abcissa	Volumetric flow QG in m ³ /h	Density ratio dv to air	Conversion factor $f = \frac{1}{dv}$
1	Air	1	1
2	Natural gas	0.61	1.28
3	Propane	1.562	0.8
4	Town gas	0.46	1.47

Conversion to air (m³/h) from other types of gases: $QL = \frac{QG}{f}$ QL = air volume in m³/h that produces the same pressure drop as QG

When used in connection with actuators having an integrated governor, the nominal valve size should not be selected too large to ensure good control performance.

Dimensions

Dimensions in mm

VG / DN50

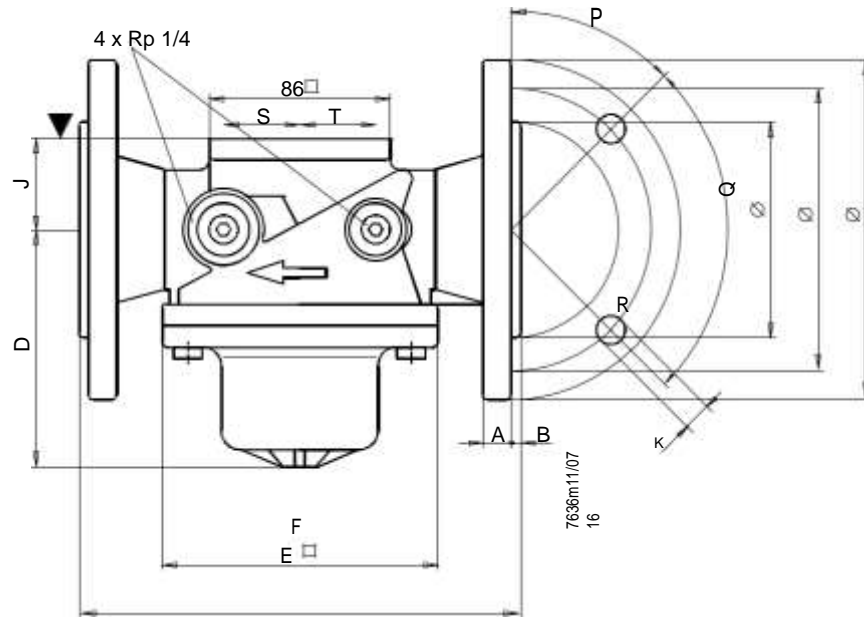

VG / DN65...80

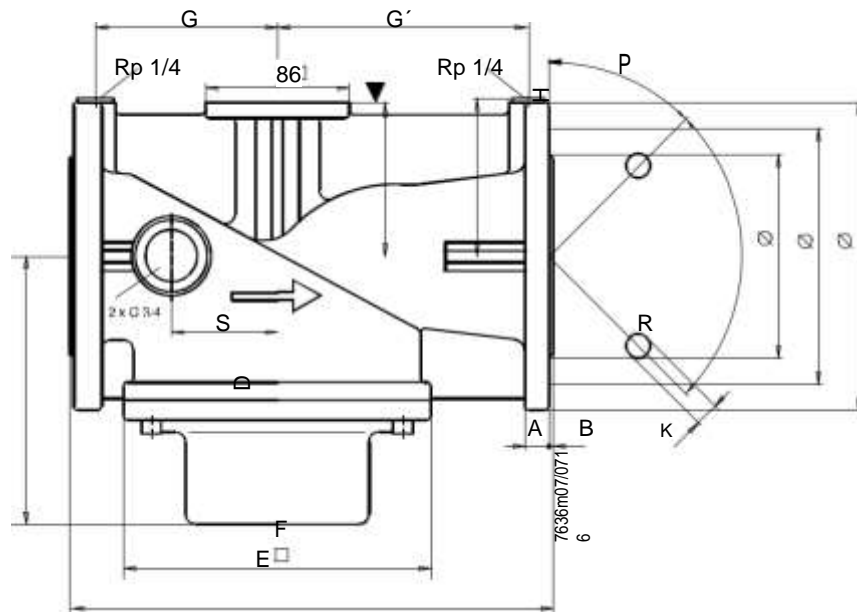

Dimensions (cont'd)

Dimensions in mm

VGG / 3"

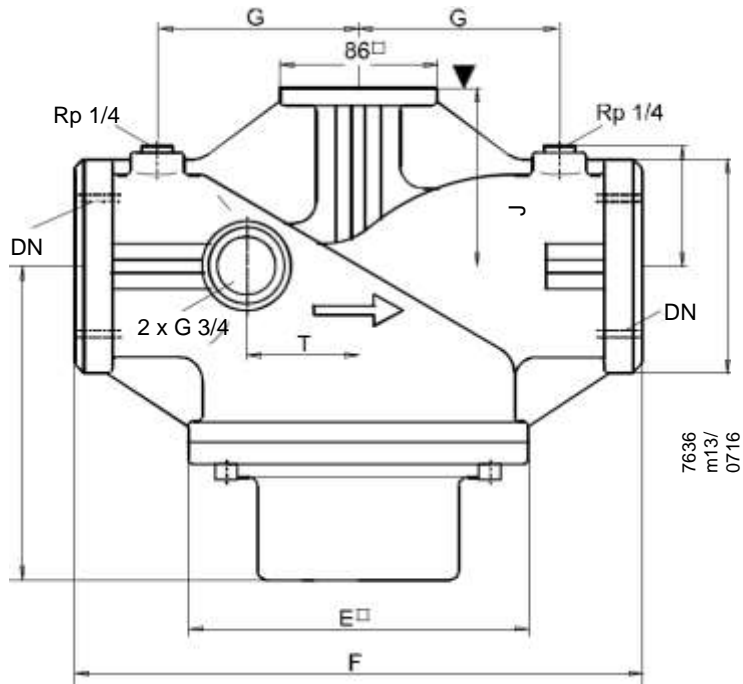

VGG 1/2" ... 2"

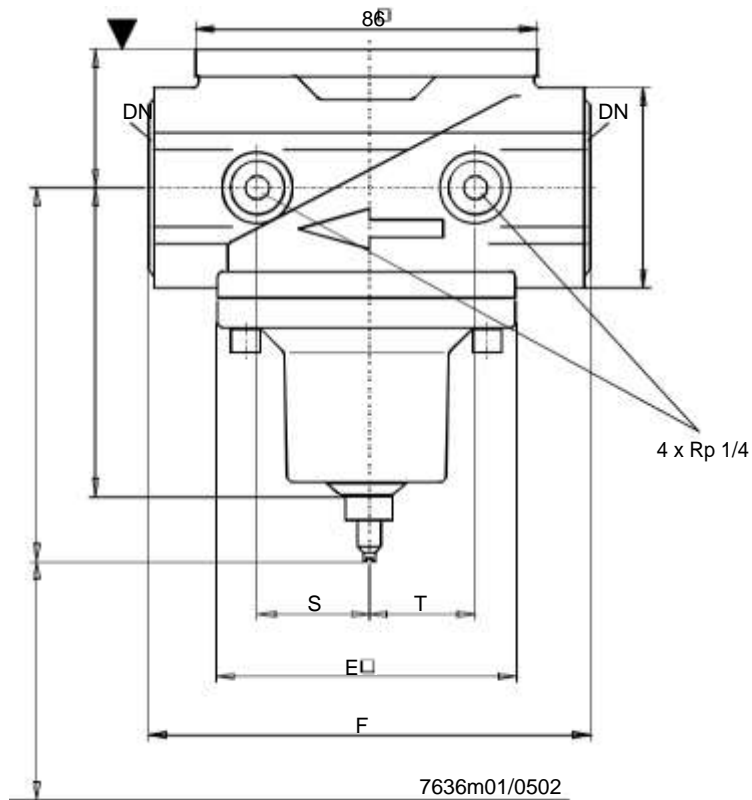

▼ Mounting surface for actuator or AGA60 adapter flange for SAX31... actuator

Dimensions (cont'd)

Table of dimensions

Type	DN 1)	A	B	C 2)	D 3)	E □	F	G	G'	H	J	K	L ∅	M ∅	N ∅	P	Q	R	S	T	SW*	kg
VGG10.15...	1/2"	---	---	96	79	80	109	---	---	---	32	---	---	---	---	---	---	---	28	31	46	0,8
VGG10.20...	3/4"	---	---	96	79	80	109	---	---	---	32	---	---	---	---	---	---	---	28	31	46	0,8
VGG10.25...	1"	---	---	96	79	80	109	---	---	---	32	---	---	---	---	---	---	---	28	31	46	0,75
VGG10.40...	1 1/2"	---	---	126	102	126	150	---	---	---	41	---	---	---	---	---	---	---	34	34	60	1,4
VGG10.50...	2"	---	---	130	107	126	170	---	---	---	50	---	---	---	---	---	---	---	34	34	75	1,95
VGG10.80...	3"	---	---	---	163	185	310	110	110	68	100	---	---	---	---	---	---	---	---	62	120	13,4
VGF10.50...	DN50	13	3	---	107	126	230	---	---	---	50	19	165	125	102	45°	90°	4	42	42	---	7,5
VGF10.65...	DN65	16,5	3	---	163	185	290	108	108	95	92	19	185	145	120	45°	90°	4	---	---	---	15,3
VGF10.80...	DN80	19	3	---	163	185	310	118	118	102	100	19	200	160	131	22,5°	45°	8	---	---	---	17,9

DN Nominal size, dimension for connection of medium

1) Flange conforming to ISO 7005-2

2) With stroke limitation

3) Without stroke limitation

R Number of boreholes; for standards for flanges and threads, see Type summary gas valves

*Width across flats

Building

Subject to change! Technologies Division

©2016 Siemens AG Building Technologies Division, Berliner Ring 23, D-76437 Rastatt